

VAC. CABLE ASSY
SEE DETAIL ABOVE

TYP LEG
ELEMENT

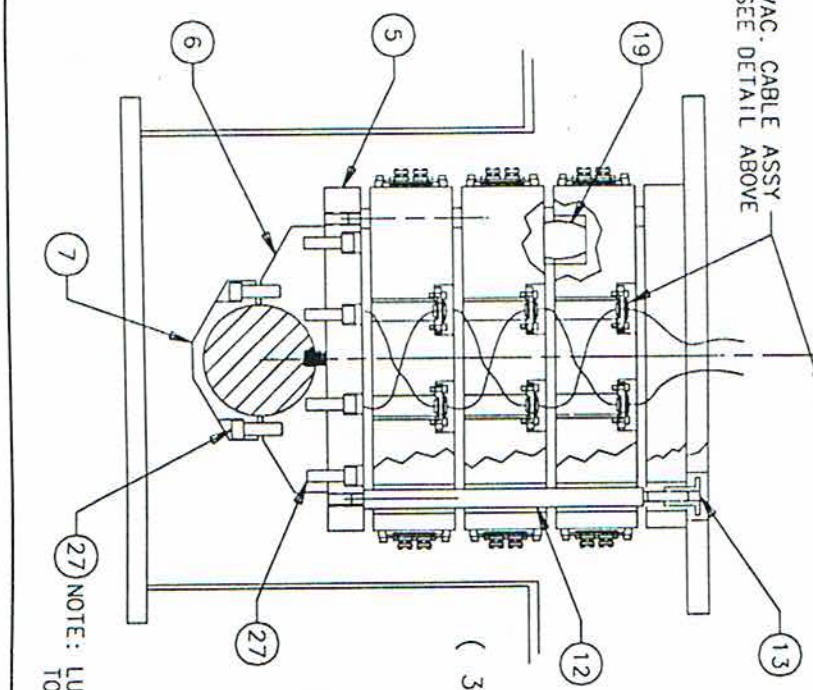

(5.50)

(36.00)

OPTICAL CL

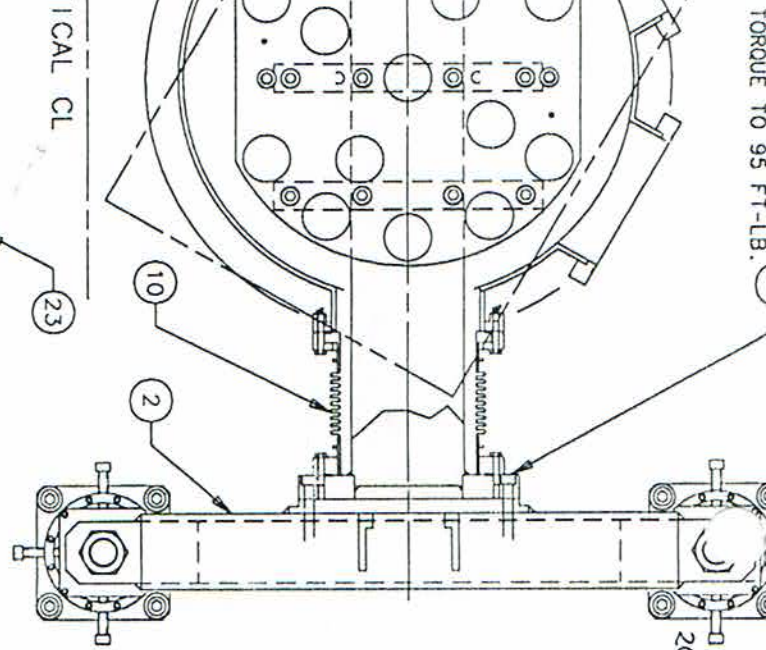

.50 NOMINAL
SELECT # OF
SPRINGS TO
MAINTAIN
SPACING

Thermal insulator

metal spacers

Paint

QTY	PART NAME
1	1101012
1	1205429
1	1205433
3	1205435
1	1205436
3	1205437
1	1205438
1	1205441
2	1205442
2	1205444
12	1205445
2	1205446
24	1205445
AR	1205446
3	1205451
AR	1205446
24	#2-56X.5
22	1/4-20X1
8	78794-8C
24	78794-10
24	#4-4

SCALE: 1/4
ISO

NOTE: LUBRICATE THREADS
TORQUE TO 95 FT-LB.

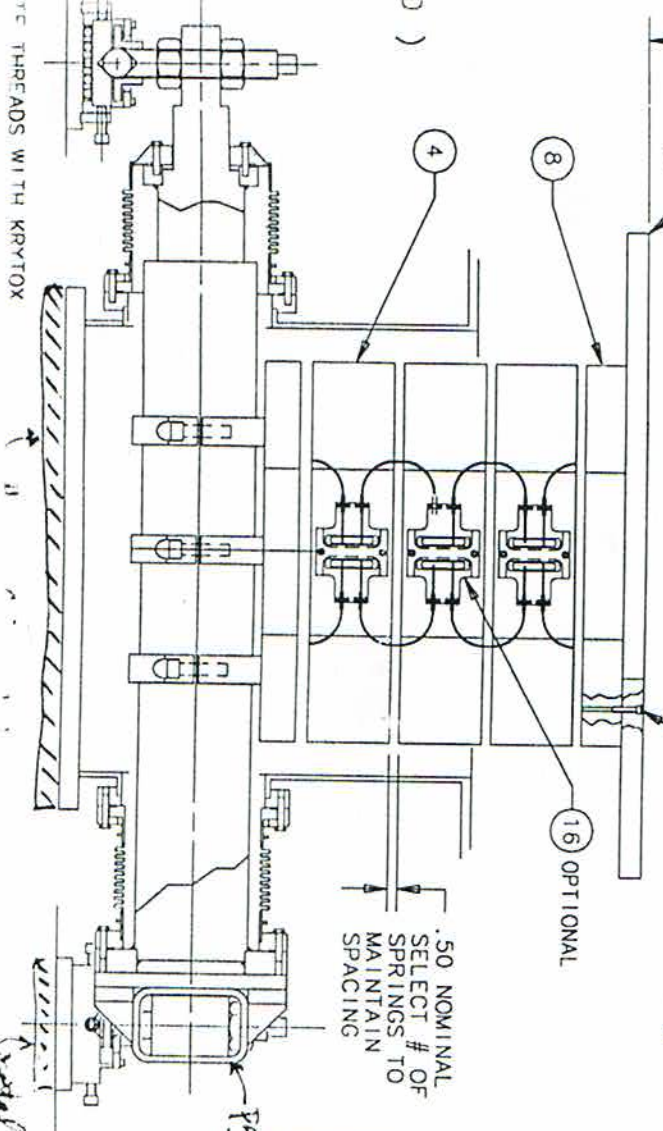
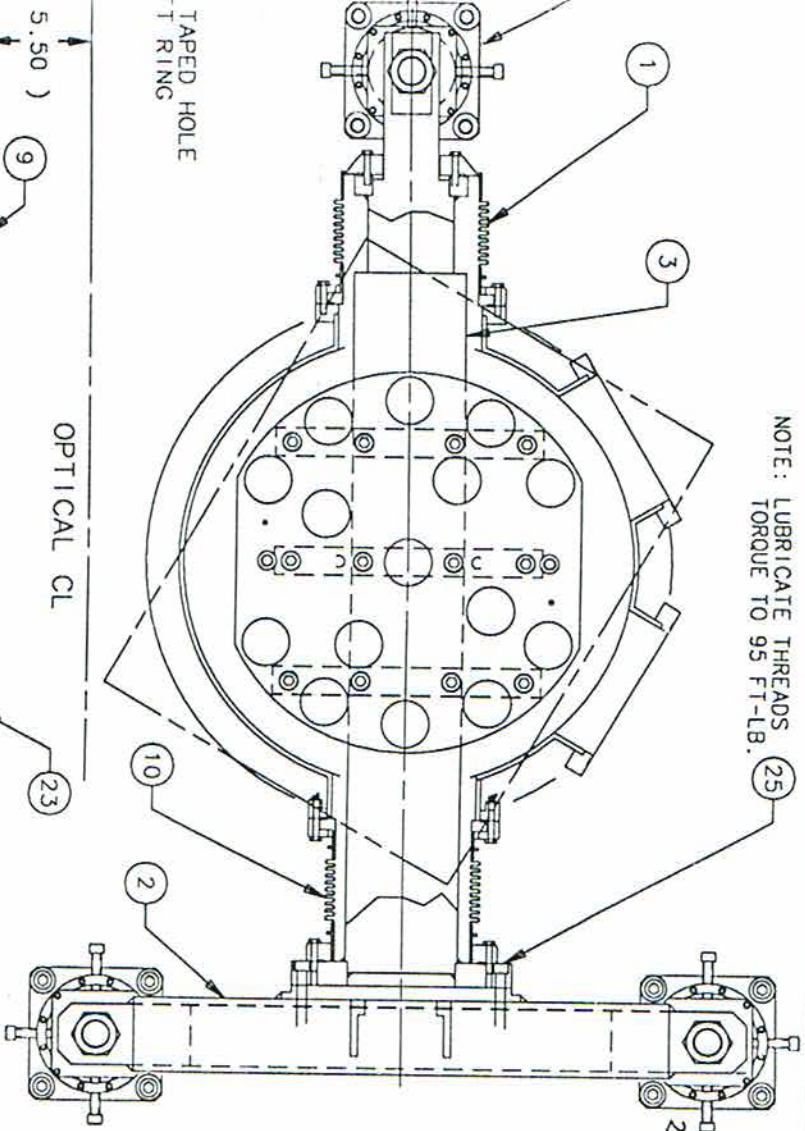

QTY	PART NUMBER	DESCRIPTION	ITEM NO.
24	#4-40	HEX NUT	30
			29
			28
			27
			26
			25
			24
			23
			22
			21
			20
			19
			18
3	1205451	DRIFT COMPENSATOR ASSY	17
AR	1205446	MODIFIED CONN. BRACKET	16
24	1205445-2	CAPTIVE SCREW	15
12	1205445-1	CARRIER, STK CONN.	14
2	1205444	EQ STOP NUT	13
2	1205443	EQ. STOP BAR	12
2	1205442	STACK ASSEMBLY TOOL	11
1	1205441	REAR ISOLATION BELLOWS	10
1	1205439	TOP PLATE	9
1	1205438	TOP LEG ELEMENT	8
3	1205437-2	LOWER BEAM CLAMP	7
3	1205437-1	UPPER BEAM CLAMP	6
1	1205436	SUPPORT PLATE	5
3	1205435	LEG ELEMENT	4
1	1205433	SUPPORT BEAM WELDMENT	3
1	1205429	CROSS BEAM WELDMENT	2
1	1101012	Ø7" ISOLATION BELLOWS	1

CALIFORNIA INSTITUTE OF TECHNOLOGY
 MASSACHUSETTS INSTITUTE OF TECHNOLOGY
LIGO PROJECT
 ISOLATION STACK ASSY
 SIDE CHAMBER