

Trillium 240

Seismometer

User Guide

© 2008 Nanometrics Inc. All Rights Reserved.

Patents US 7,388,806, US 7,376,049, US 7,385,873, GB2422434, GB2423153, GB2422435, US and foreign patents pending.

Trillium 240 Seismometer User Guide

The information in this document has been carefully reviewed and is believed to be reliable. Nanometrics Inc. reserves the right to make changes at any time without notice to improve the reliability and function of the product.

No part of this publication may be reproduced, stored in a retrieval system or transmitted, in any form or by any means, electronic, mechanical, photocopying, recording, or otherwise, without the prior written permission of Nanometrics Inc.





Nanometrics Inc.
250 Herzberg Road
Kanata, Ontario, Canada K2K 2A1
Tel +1 613-592-6776
Fax +1 613-592-5929
Email info@nanometrics.ca
www.nanometrics.ca

Part number 15672R4

Release date 2008-12-17

Document Conventions

Essential and Supplementary Information

	Warning	Explains a risk of irreversible damage to data, software, or equipment and provides recommendations for preventive action.
	Caution	Explains a risk of damage to data, software, or equipment where recovery is likely to be troublesome and provides recommendations for preventive action.
	Note	Provides additional information related to the current text.
	Tip	Explains a best practice or provides helpful information related to the current text.

Text Conventions

bold text	Identifies referenced elements in the graphical user interface (GUI) (for example, "click Cancel to discard the changes").
<i>italic text</i>	Identifies variables such as parameter names and value placeholders (for example, "select Configuration > <i>Sensor Name</i> ").
<code>courier text</code>	Identifies commands that must be entered exactly as shown (for example, "enter <code>mkdir \$APOLLO_LOCATION/config</code> ").

Contents

Document Conventions	iii
--------------------------------	-----

Part 1 Installation

Chapter 1 Getting Started

1.1 About Trillium 240 Seismometers	3
1.2 Unpacking and Handling a Trillium 240	3
1.3 Preparing to Install a Trillium 240	4
1.4 Trillium 240 Optional Equipment	5
1.5 Technical Support and Maintenance	6
1.5.1 Recording Your Serial Number	6

Chapter 2 Selecting and Preparing a Site

2.1 Selecting a Site	7
2.2 Planning Your Installation	7
2.2.1 Common Types of Installations	8
2.3 Recommendations for Pier Construction	9
2.3.1 Choosing the Right Concrete	9
2.3.2 Decoupling the Pier and Vault Walls	9
2.4 Site Record	10

Chapter 3 Installing a Trillium 240

3.1 Alignment, Levelling, and Placement Features	11
3.2 Best Practices for Aligning and Levelling a Trillium 240	12
3.3 Theory and Practice of Insulation	13
3.4 Insulation Options	14
3.4.1 Insulating a Trillium 240 with the Insulating Cover	15
3.4.2 Insulating a Trillium 240 with a Rigid Foam Box	16
3.5 Installing a Trillium 240 in the Insulating Cover	17

Chapter 4 Post-Installation Activities

4.1 Grounding the Digitizer and Trillium 240	19
4.2 Centring the Masses after Installation	19
4.3 Installation Checklist	20
4.4 Troubleshooting Your Installation	20

Part 2 Operation

Chapter 5 Input and Output Signals

5.1 Digital Control Input Signals	23
5.2 UVW and XYZ Output Signals	23
5.3 Calibration Input Signals	25
5.4 State-of-Health Output Signals	25
5.5 Power Consumption	26

Chapter 6 Using a Nanometrics Digitizer with a Trillium 240

6.1 Using a Taurus Portable Seismograph with a Trillium 240	27
6.2 Using a Trident Digitizer with a Trillium 240.	28
6.3 Increasing System Sensitivity.	29

Chapter 7 Centring the Masses

7.1 About Mass Centring	31
7.2 Choosing When to Initiate Mass Centring	32
7.3 Initiating Mass Centring Using a Standard Cable and Digitizer.	33
7.4 Initiating Mass Centring using a Serial Cable and Laptop	34

Chapter 8 Setting Up Serial Port Communications

8.1 Connecting to and Configuring the Serial Port	35
8.2 Serial Port Commands	36

Part 3 Reference

Chapter 9 Specifications

9.1 Technology.	43
9.2 Interface	43
9.3 Physical.	44
9.4 Power	44
9.5 Performance	44
9.6 Environmental	45

Chapter 10 Transfer Function

10.1 Frequency Response	48
10.2 Self-Noise.	51

Chapter 11 Connector and Cables

11.1 Connector Pinout.	54
11.2 Seismometer Cable Pinout	55
11.3 Cable Design Guidelines	57

Chapter 12 Alignment Features and Dimensions

12.1 Top View of Alignment Features 59
 12.2 Bottom View of Alignment Features and Dimensions 60
 12.3 Side View of Dimensions 61

Appendix A Glossary

A.1 Glossary of Abbreviations and Terms 63
 A.2 List of Unit Abbreviations and Symbols 66

About Nanometrics 67
 Contacting Nanometrics 67
 Contacting Technical Support 67

Tables

1-1	List of Trillium 240 optional equipment	5
2-1	Recommended pier design specifications	9
2-2	Record of installation site details	10
4-1	Types of noise and possible causes	20
5-1	Axis orientation and polarity of XYZ outputs	23
6-1	Increasing system sensitivity	29
8-1	Serial port commands	36
9-1	Technology specifications	43
9-2	Interface specifications	43
9-3	Physical specifications	44
9-4	Power specifications	44
9-5	Performance specifications	44
9-6	Environmental specifications	45
10-1	Ground motion response nominal parameters	49
10-2	Calibration input response nominal parameters	50
10-3	Combined calibration response nominal parameters	50
11-1	Connector pinout	54
11-2	Seismometer cable wiring for cable 16169-nM (for Nanometrics digitizers)	55
11-3	Seismometer cable wiring for cable 16170-nM (open-ended cable)	56
A-1	Unit Abbreviations and Symbols	66

Figures

- 3-1 Example of seismometer alignment using vertically scribed marks 12
- 3-2 Location of gasket plugs 15
- 3-3 Insulating cover installation options 15
- 3-4 Trillium 240 seismometer insulating cover dimensions. 16
- 5-1 Trillium 240 axis orientation 24
- 10-1 Bode plot for Trillium 240 seismometers 48
- 10-2 Trillium 240 self-noise 51
- 10-3 Trillium 240 performance 52
- 12-1 Top view of alignment features. 59
- 12-2 Bottom view of alignment features and dimensions 60
- 12-3 Side view of alignment features 61

Part 1

Installation

- ◆ Getting Started
- ◆ Selecting and Preparing a Site
- ◆ Installing a Trillium 240
- ◆ Post-Installation Activities

Chapter 1

Getting Started

- ◆ [About Trillium 240 Seismometers](#)
- ◆ [Unpacking and Handling a Trillium 240](#)
- ◆ [Preparing to Install a Trillium 240](#)
- ◆ [Trillium 240 Optional Equipment](#)
- ◆ [Technical Support and Maintenance](#)

1.1 About Trillium 240 Seismometers

Trillium 240 seismometers are three-component, very broadband, low-noise seismometers suitable for portable and fixed applications. With an extended low frequency range useful out to beyond 1000 s, ability to resolve Peterson's new low-noise model (NLNM) down to a 100 s period, low noise, and wide dynamic range, these observatory-class seismometers are ideal for teleseismic, regional, and local studies.

The symmetric triaxial arrangement of the sensing elements in Trillium 240 seismometers ensures uniformity between vertical and horizontal outputs. The ability to remotely select either the raw (UVW) or resulting horizontal-vertical (XYZ) outputs allows for the calibration of each axis separately. For some studies, it may be preferable to use UVW mode instead of XYZ mode for recording seismic data.

Each Trillium 240 is equipped with an automatic mass recentring capability that facilitates both local and remote recentring.

1.2 Unpacking and Handling a Trillium 240

The shipping box and packing foam for Trillium 240 seismometers have been designed and tested to protect the seismometers against the impact of accidental drops during hand-carrying and from vibration and shock during shipping. To maintain warranty protection, Trillium 240 seismometers must always be transported in packaging approved by Nanometrics. Save the original packaging and reuse it any time you are transporting a Trillium 240. If custom packaging is required for a particular application, please consult Nanometrics (see [Contacting Nanometrics](#) on page 67).

After delivering a Trillium 240 to its installation site, you can safely remove it from the packaging and handle it without any special precautions other than taking care not to drop it or bang it against hard surfaces. Trillium 240 seismometers do not require any mass lock mechanisms. The seismometer is ready to operate right out of the box and can withstand shocks of up to 20 *g* with no degradation in performance or service life.

Trillium 240 seismometers come with a removable lifting handle. Do not use this handle to carry your seismometer over long distances. The handle should only be used to help lift or carry the seismometer at the installation site. For more information on using the handle, see [Section 3.1 “Alignment, Levelling, and Placement Features”](#) on page 11.



Do not use the lifting handle to carry your Trillium 240 seismometer over long distances as the seismometer could gradually rotate and fall off of the handle.

1.3 Preparing to Install a Trillium 240

Advanced planning and preparation for the installation of your Trillium 240 seismometer will ensure that you have a properly prepared site and the tools and materials you need readily available. Follow these recommendations when preparing for your installation:

- ♦ Select and prepare your site.

If the site requires the construction of a pier or other time-consuming labour, factor this time into your installation schedule. See [Chapter 2 “Selecting and Preparing a Site”](#) for more information.
- ♦ Select your insulation method.

You can thermally insulate your seismometer with the Trillium 240 Insulating Cover (recommended) or make a freestanding cover out of rigid plastic foam. Determine which method you will use before your installation so that you have the necessary materials on-site. For more information on insulating your seismometer, see [Section 3.3 “Theory and Practice of Insulation”](#) on page 13 and [Section 3.4 “Insulation Options”](#) on page 14.
- ♦ Gather your installation tools and materials. At a minimum you should have the following on-site when installing your seismometer:
 - Thermal insulation
 - Power source
 - Digitizer and cable (see [Table 1-1 “List of Trillium 240 optional equipment”](#) on page 5 for information on Nanometrics digitizers and cables)
 - Compass and drawing utensils for alignment (see [Section 3.2 “Best Practices for Aligning and Levelling a Trillium 240”](#) on page 12)
- ♦ Gather any optional tools and materials you may need. Your installation may also require:
 - A laptop with software and cables required to connect to and communicate with the digitizer if using a digitizer without a display screen.
 - Alignment rods if you are aligning the seismometer to the north-south using the 5/16 in. diameter holes in the seismometer base. Using the east-west scribe lines is preferred. See [Section 3.1 “Alignment, Levelling, and Placement Features”](#) on page 11.
 - Lifting handle if you are installing the seismometer in a vault that is only accessible from the top.

1.4 Trillium 240 Optional Equipment

Nanometrics offers optional equipment that add convenience to the installation and use of your Trillium 240 seismometer. The table below describes a number of these options.

Table 1-1 List of Trillium 240 optional equipment

Name	Part Number	Description
Trillium 240 Insulating Cover	16060	Easily installed system that provides thermal insulation and protection from external air currents. Includes a foam base gasket and a rigid form-fitting cover matched to the Trillium 240. Properly installed, the cover attenuates temperature-induced long period noise by up to 40 dB. Requires a flexible cable with a right-angle connector.
Cable – Trillium seismometer to Nanometrics digitizer	16169–3M 16169–5M 16169–10M 16169–15M 16169–25M	Double-shielded, ultra-flexible cable with Trillium 240 seismometer right-angled connector on one end and Nanometrics digitizer connector on the other end for connecting a Taurus or Trident. Standard cable lengths are 3 m, 5 m, 10 m, 15 m, and 25 m. Custom cable lengths are available upon request.
Cable – Trillium seismometer to Nanometrics digitizer, regulating	16163–3M 16163–5M 16163–10M 16163–15M 16163–25M	Double-shielded, ultra-flexible cable with Trillium 240 seismometer right-angled connector on one end and Nanometrics digitizer connector on the other end for connecting a Taurus or Trident. Digitizer connector contains a power supply that filters out power-induced noise. Standard cable lengths are 3 m, 5 m, 10 m, 15 m, and 25 m. Custom cable lengths are available upon request.
Cable – Trillium seismometer to open end	16170–3M 16170–5M 16170–10M 16170–15M 16170–25M	Double-shielded, ultra-flexible cable with Trillium 240 seismometer right-angled connector on one end and open-ended at the other end for attaching the connector of a third-party digitizer. Standard cable lengths are 3 m, 5 m, 10 m, 15 m, and 25 m. Custom cable lengths are available upon request.
Cable – Trillium seismometer to third party digitizer	Contact Nanometrics	Double-shielded, ultra-flexible cable with Trillium 240 seismometer right-angled connector on one end and a connector for a common third party digitizer, such as a Q330 or REFTEK D130 on the other end. Contact Nanometrics (see Contacting Nanometrics on page 67) for a full listing of cables with connectors to third party digitizers.
Cable – Serial communications cable	15766	Cable to enable serial communications between a Trillium 240 seismometer and a laptop. Contact Nanometrics (see Contacting Nanometrics on page 67) for more details.
Alignment rods	Contact Nanometrics	Rods that fit into the 5/16 in. diameter holes on the base of a Trillium 240 seismometer. Used for aligning the seismometer to north-south. Contact Nanometrics (see Contacting Nanometrics on page 67) for more details.

Table 1-1 List of Trillium 240 optional equipment

Name	Part Number	Description
Taurus Portable Seismograph	14977	<p>Compact, self-contained, 24-bit digitizer and data logger with low power consumption, and 142 dB dynamic range. Use as a stand-alone time-series data logger or as a component in a data acquisition network.</p> <p>Incorporates a three-channel 24-bit digitizer, GPS receiver and system clock, removable data storage, and remote communication options.</p> <p>Can be installed in the seismometer vault, requiring only a short cable.</p> <p>Configurable locally using the colour display screen and integrated browser or remotely using any Web browser over a TCP/IP connection.</p>
Trident 305 Digitizer	14072	<p>A 24-bit digitizer with 142 dB dynamic range and Nanometrics NMX-bus for connecting to Taurus, Cygnus satellite transceiver, or other NMX-bus enabled device.</p> <p>The NMX-bus host device, such as a Taurus, supplies GPS timing and power to the Trident.</p> <p>Can be installed in the seismometer vault, requiring only a short cable.</p> <p>Weather-sealed enclosure also allows outdoor installations.</p> <p>Configurable locally using the host Taurus or remotely using any Web browser over a TCP/IP connection.</p>

1.5 Technical Support and Maintenance

If you need technical support, please submit your request by email or fax. Include a full explanation of the problem and any supporting information (such as mass position readings, photographs of the site, operating input voltage and current) to help us direct your request to the most knowledgeable person for reply. Before returning a unit for repair, contact Nanometrics Technical Support (see [Contacting Technical Support](#) on page 67) to obtain an RMA number.

The Trillium 240 mechanical and electronic elements have been designed to be robust and reliable, to ensure there is no need to open units for on-site maintenance. The internal reverse-voltage protection and over-current protection automatically resets when the fault is removed, so there are no fuses to replace. The automatic mass tensioner mechanism is designed to be jam-proof.

1.5.1 Recording Your Serial Number

The serial number of your Trillium 240 is located on the seismometer, below the connector. Record the serial number and keep it accessible. You need to reference this number when contacting Technical Support.

Chapter 2

Selecting and Preparing a Site

- ♦ [Selecting a Site](#)
- ♦ [Planning Your Installation](#)
- ♦ [Recommendations for Pier Construction](#)
- ♦ [Site Record](#)

2.1 Selecting a Site

There is no substitute for a geological survey when it comes to site selection. A survey provides knowledge of the structures over which the seismometer will be installed.

Where possible, seismometers should be installed on bedrock and as far away as possible from sources of cultural noise such as roads, dwellings, and tall structures. Low porosity is important as water seepage through the rock can cause tilts which overwhelm the seismic signal at long periods. Clay soils and, to a lesser extent, sand are especially bad in this sense.

Use the worksheet in [Section 2.4 "Site Record"](#) on page 10 to record information about the structure, cultural environs, and climatic conditions of the site; as well as information about the type and length of the installation. [Section 2.2.1 "Common Types of Installations"](#) on page 8 provides recommendations for some common installation types.

2.2 Planning Your Installation

Before deploying your seismometer, you should have an understanding of the type of installation you will use and how you will insulate your seismometer. Your installation must be designed to provide a stable base for the seismometer without any forces or disturbances acting on it.

The installation methods described in this section incorporate installation design guidelines that aim to reduce the possibility of installation-related noise. Horizontal spikes in the signal are indicative of installation-related issues, and it is normal to see horizontal spikes following installation. However, if the spikes do not diminish after a few days, there may be a problem with the installation. See [Section 4.4 "Troubleshooting Your Installation"](#) on page 20 for more information.

2.2.1 Common Types of Installations

Following are three common methods for installing and insulating a seismometer (see [Section 3.3 "Theory and Practice of Insulation"](#) on page 13 and [Section 3.4 "Insulation Options"](#) on page 14 for more information on insulation):

a) Vault installation

Vault installations can be at or below the surface and usually include a pier that provides a level platform for the seismometer to sit on and good coupling to the ground.

The pier must be insulated from air currents to prevent tilt noise caused by the thermal expansion or contraction of its surface. For a pier solidly connected to the ground (such as a poured cement pad on top of bedrock), a useful technique is to place a thick quilt over the surface of the pier. Cutting a hole out of the quilt allows it to drop over the insulating cover of the seismometer and cover the pier.

Thoroughly insulate the roof of the vault and any exposed sides. Seal the door and any other openings. Do not use a thermostat-controlled heating or cooling system because the temperature cycling will show up as periodic noise in the seismic signal.

b) Temporary deployment on rock

Install the seismometer on the flattest available surface and lay sand in a ring around it to create a flat sealing surface for the rigid insulation that will cover it.

c) Temporary deployment in sediment

Dig a pit to bury the seismometer. A depth of 2 ft. is sufficient to ensure the seismometer and insulation will be completely covered and not disturbed. If possible, place a metal plate or paving stone at the bottom of the pit to create a hard, flat surface. Install the seismometer in the pit and cover it with a rigid insulating cover. The cover will prevent the seismometer from being disturbed by sediments shifting and settling against it. Hold the cover down while piling sediment around it to ensure that it does not shift as it is buried.

A simpler but less optimal method is to place the seismometer directly in the ground and bury it. This method provides good insulation, but horizontal noise spikes may be observed due to instability of the soil.

2.3 Recommendations for Pier Construction

If your installation involves the construction of a pier, use [Table 2-1](#) as a guide to constructing your pier:

Table 2-1 Recommended pier design specifications

Material	Concrete. Homogeneous, 50% Portland cement and 50% sieved sand (see Section 2.3.1 "Choosing the Right Concrete" on page 9).
Size	Large enough to fit all required seismometers, cables, and insulation.
Thickness	Within the range of 2 in. to 4 in. on top of bedrock.
Surface	Smooth, level, and clear of debris.
Decoupling	Decouple the pier from the vault walls (see Section 2.3.2 "Decoupling the Pier and Vault Walls" on page 9).

2.3.1 Choosing the Right Concrete

The concrete used in a seismic pier should be as homogeneous as possible to avoid inducing tilts from differing thermal coefficients of expansion. To create a homogeneous concrete mixture do not use any aggregates and ensure the concrete is free of air bubbles. Steel reinforcement is not necessary as strength is not a concern in seismic piers.

The recommended concrete mixture is 50 percent Portland cement and 50 percent sieved sand.¹ After pouring the concrete, shake it to allow trapped bubbles to escape. Allow 24-hours for the concrete to harden before positioning the seismometer on the pier.



The pier may generate spurious signals as the concrete cures, which can take two to four weeks.

2.3.2 Decoupling the Pier and Vault Walls

When setting up the concrete forms for the pier, include a gap between the edge of the concrete and the walls of the vault. Decoupling the pier and the vault walls prevents the transfer of non-seismic forces, such as wind, from the vault walls to the pier. Such forces can cause the pier to tilt or twist and obscure the desired seismic signal. These signals are mostly long period, so vault wall decoupling is critical for quiet site long period studies.

1. Bob Uhrhammer and Bill Karavas, *Guidelines for Installing Broadband Seismic Instrumentation* (Berkeley: The Regents of the University of California, 1997), <http://seismo.berkeley.edu/bdsn/instrumentation/guidelines.html>.

2.4 Site Record

Use the following table to record information about the site, including its structure, cultural environs, and climatic conditions. This information will be helpful in identifying changes to the site over time and for determining when mass recentring may be necessary due to temperature change.

Table 2-2 Record of installation site details

Site name (full name / station code / network code, for example, Yellowknife / YKN / CN):	Latitude:
	Longitude:
	Elevation:
	Date of installation (mm/dd/yyyy):
Type of installation (for example, vault, surface, other): _____ Depth below surface (m) _____ Height above sea level (m)	Length of installation: Permanent or temporary: If temporary, expected time frame (mm/dd/yyyy to mm/dd/yyyy):
Ground surface type (for example, rock, soil, sand, clay, other):	Distance to potential noise sources (km): _____ Airport or air traffic _____ Railway _____ Roads _____ Tall structures _____ Height (m) _____ Trees _____ Height (m) _____ Dwellings _____ Industrial site _____ Others (describe):
Seasonal temperature ranges (°C): _____ January 1 to March 31 _____ April 1 to June 30 _____ July 1 to September 30 _____ October 1 to December 31	
Notes:	

Chapter 3

Installing a Trillium 240

- ◆ [Alignment, Levelling, and Placement Features](#)
- ◆ [Best Practices for Aligning and Levelling a Trillium 240](#)
- ◆ [Theory and Practice of Insulation](#)
- ◆ [Insulation Options](#)
- ◆ [Installing a Trillium 240 in the Insulating Cover](#)

3.1 Alignment, Levelling, and Placement Features

To aid in the proper alignment of your seismometer, each Trillium 240 has:

- ◆ Vertically-scribed marks on the east-west axis.
- ◆ Two 5/16 in. diameter holes on the north-south axis for fitting alignment rods.

For convenience and accuracy, use of the east-west scribe marks is the preferred method of alignment. Alternatively, for a north-south alignment, alignment rods are available from Nanometrics that you can fit into the 5/16 in. diameter holes on the north-south axis of the seismometer base. [Chapter 12 "Alignment Features and Dimensions"](#) provides illustrations that show the relative orientation of the east-west and north-south alignment features in top, bottom, and side views.

For levelling purposes, each Trillium 240 seismometer is equipped with:

- ◆ Three adjustable-height feet with lock nuts.



If a sufficiently flat and level installation surface is available, the feet can be removed and the seismometer will rest on three raised bosses that are located on the bottom of the seismometer base.

- ◆ A levelling bubble on the cover.

Trillium 240 seismometers also come with a lifting handle that can be screwed into the top of the seismometer cover. The handle is provided to facilitate the placement of these seismometers in vaults that are only accessible from the top, or to carry the seismometer over short distances. Remove the handle when the seismometer installation is complete to allow for close-fitting insulation.



Do not use the lifting handle to carry your Trillium 240 seismometer over long distances as the seismometer could gradually rotate and fall off of the handle.

Figure 3-1 shows the west scribe line on a Trillium 240 aligned with a line drawn on the pier that is parallel to east-west. One of the levelling feet to the left of the alignment marker is also visible.

Figure 3-1 Example of seismometer alignment using vertically scribed marks



3.2 Best Practices for Aligning and Levelling a Trillium 240

Following are best practices for aligning and levelling a Trillium 240 using the vertically scribed marks on the east-west axis:



If you are using a north-south alignment with the alignment rods, continue with these best practices, but substitute east-west with north-south and fit the alignment rods into the 5/16 in. diameter holes in the base of the seismometer instead of aligning the Trillium 240 with the vertically scribed marks.

- ♦ Draw a line on the pier or other installation surface parallel to east-west.
The east-west line must be aligned to true east. If you are using a magnetic compass, account for the local magnetic declination when drawing the line. For underground installations, you can transfer north measured at the surface to below ground by traversing with survey equipment.
- ♦ If you are insulating the seismometer using the Trillium 240 Insulating Cover, see [Section 3.5 “Installing a Trillium 240 in the Insulating Cover”](#) on page 17 for instruction on aligning the foam base gasket of the cover and for placing the seismometer on the base.
- ♦ When you are ready to remove the Trillium 240 seismometer from the box, gently place it on the installation surface in an approximate east-west alignment.
- ♦ Use the adjustable feet, as required, and the levelling bubble on the cover to level the seismometer. Centre the bubble as precisely as possible inside the black ring to ensure that the Z output is measuring true vertical motion.

Extend the levelling feet as little as possible to achieve a level seismometer. Try to keep one of the feet fully retracted into the seismometer base.

- ♦ When the Trillium 240 is level, lock the feet by threading the lock nut up until it engages firmly with the base of the seismometer. A foot that is properly locked will not turn easily when touched.
- ♦ Precisely align the Trillium 240 to east-west by aligning the vertical east-west lines on the base of the seismometer (see [Figure 3-1 “Example of seismometer alignment using vertically scribed marks”](#) on page 12) with the line drawn on the installation surface.
Some care is required when aligning the seismometer to avoid sighting at an angle and introducing a parallax error.
- ♦ After aligning the seismometer, verify that it is still level. It may need to be adjusted due to unevenness of the installation surface.
- ♦ If you relevelled the Trillium 240, ensure the feet are locked when finished.

3.3 Theory and Practice of Insulation

Seismometer installations must be thermally insulated to achieve optimal performance, particularly at long periods. There are two broad categories of thermal effects that can cause unwanted noise:

a) Direct thermal sensitivity.

The Trillium 240 is designed to minimize temperature sensitivity; however, like all seismometers, it has some residual thermal response. There are several components in a seismometer that are temperature sensitive, such as the springs that suspend the inertial masses. The effect of direct thermal sensitivity typically shows up as very long period noise on the vertical channel, in particular, a periodic diurnal variation in response to the day-to-night temperature cycle.

b) Thermally induced tilt.

All seismometers are susceptible to thermally induced tilt. Tilt converts the strong vertical acceleration of gravity into an apparent horizontal acceleration. There are many mechanisms for the conversion of temperature into tilt. For example:

- Movement of air surrounding the seismometer can cause non-uniform thermal expansion or contraction of the pier and the seismometer. Such effects typically have an apparent ground-motion spectrum that is peaked at long periods.
- Movement of anything touching the seismometer, including the digitizer cable and insulation materials, can cause forces to develop that change with temperature. Stick-slip effects typically transform these forces into sudden step changes in tilt. The apparent ground-motion power spectral density is, therefore, inversely proportional to the square of frequency.

For seismometers that are well temperature-compensated, such as the Trillium 240, but are improperly installed, thermally induced tilt on the horizontal channels will be more significant than direct thermal sensitivity on the vertical channel. Furthermore, due to the natural convection of air, thermally induced tilt is even observable in sealed underground vaults where the temperature is very stable.

Therefore, the objectives of a good installation are to:

- ♦ Insulate the seismometer from temperature changes.
- ♦ Prevent the movement of air on the surface of the seismometer.
- ♦ Insulate the pier from temperature changes.
- ♦ Prevent the movement of air on the surface of the pier, including the sides and underside of piers that consist of a slab raised above the vault floor.
- ♦ Prevent anything from touching and thereby applying a mechanical force to the seismometer.

To meet these objectives and achieve the best possible performance, observe the following practices:

- ♦ The vault (the space or room where the seismometer is installed) must provide a stable thermal environment. This environment is typically achieved through careful site selection (see [Chapter 2 "Selecting and Preparing a Site"](#)) and by installing the seismometer below ground.
- ♦ The digitizer cable must be flexible enough to bend without applying significant forces to the seismometer. Nanometrics provides ultra-flexible cables designed for this purpose (see [Section 1.4 "Trillium 240 Optional Equipment"](#) on page 5).
- ♦ The insulation surrounding the seismometer must:
 - Have low thermal conductivity to insulate the seismometer from temperature changes.
 - Form a nearly airtight seal against the pier to block drafts.
 - Fit closely around the seismometer, eliminating space that may cause convection inside the cover.
 - Not touch the seismometer. The insulation is subject to temperature expansion and can exert measurable forces on the seismometer.

3.4 Insulation Options

There are two options for insulating a Trillium 240:

- a) Use the Nanometrics Trillium 240 Insulating Cover (Nanometrics part number 16060). See also [Section 3.4.1 "Insulating a Trillium 240 with the Insulating Cover"](#) on page 15. This is the recommended method.
- b) Make a freestanding cover out of rigid plastic foam that is sealed against air drafts, does not touch the seismometer, and minimizes the volume of air trapped between the insulating box and the seismometer. See also [Section 3.4.2 "Insulating a Trillium 240 with a Rigid Foam Box"](#) on page 16.

Before proceeding with the implementation of thermal insulation, there are many aspects you must consider in the context of the particular site and type of installation. [Section 2.2 "Planning Your Installation"](#) on page 7 outlines common types of installations.

3.4.1 Insulating a Trillium 240 with the Insulating Cover

The Trillium 240 Insulating Cover is a rugged and form-fitting cover that is made of rigid plastic filled with an insulating foam core. The cover encloses the seismometer without touching it, eliminates convection by minimizing the air volume trapped under the cover, and provides a race for a coiled cable that minimizes heat and conduction through the cable. Properly installed, the insulating cover can attenuate temperature-induced long-period noise by up to 40dB.

The included foam base gasket of the cover has precut plugs that provide flexibility in how the cover is used.

Figure 3-2 Location of gasket plugs

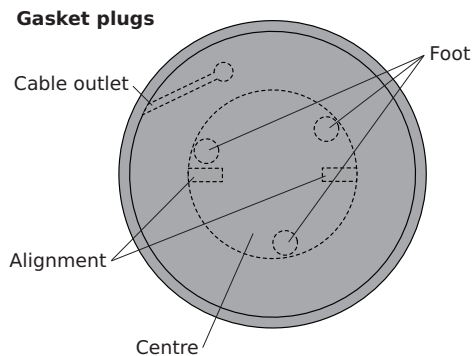

A standard installation retains the original position of the cable outlet and leads the cable around the base of the gasket, enclosing approximately 1 m of cable in the cover. Enclosing the cable in the cover helps attenuate temperature variations conducted by the cable.

If your installation requires a different exit point for the cable, you can separate the centre plug from the outer main gasket and rotate the outer gasket to move the cable outlet as required. This type of modified installation provides less insulation for the cable.

Figure 3-3 Insulating cover installation options

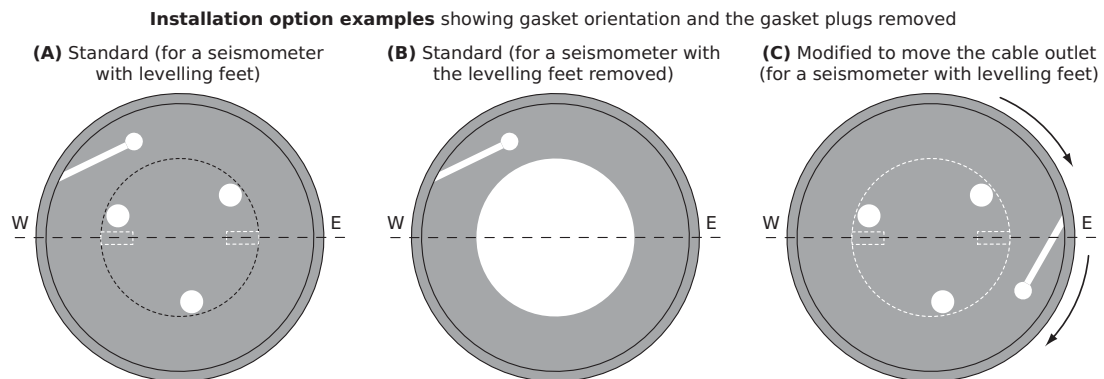
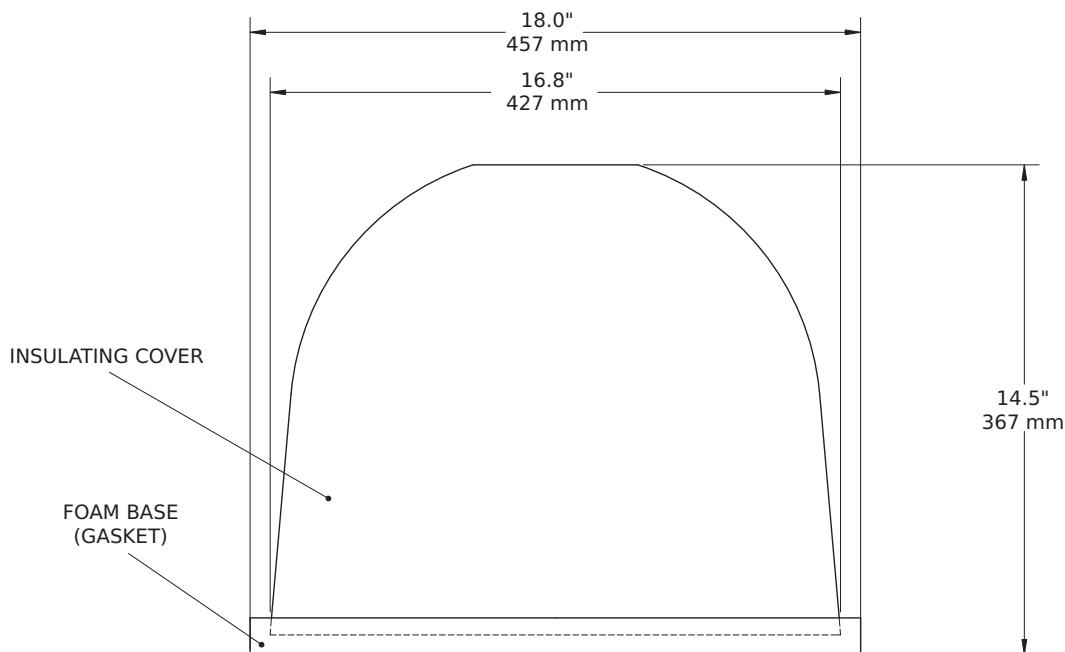



Figure 3-4 provides the dimensions of the insulating cover.

Figure 3-4 Trillium 240 seismometer insulating cover dimensions



3.4.2 Insulating a Trillium 240 with a Rigid Foam Box

If you are not using the recommended Trillium 240 Insulating Cover, insulate the seismometer with a rigid foam box. Use the following recommendations as a guide when constructing the box:

 When installing a Trillium 240 in a rigid foam insulating box, follow the best practices for aligning and levelling the seismometer that are outlined in [Section 3.2 "Best Practices for Aligning and Levelling a Trillium 240"](#) on page 12.

- ♦ Construct a five-sided box that is large enough to house the seismometer without touching the sides of the seismometer or the cable.
Preferably, use rigid foam insulation with foil on one or both sides. There are two advantages to the foil-coated foam: it has a higher insulation resistance, and you can make the joints with aluminium tape, which is quicker and cleaner than glue.
- ♦ Use insulation that is at least 5 cm (2 in.) thick. Depending on the temperature stability of the site, additional or thicker boxes can be used.
- ♦ Cut a groove at the appropriate point in the bottom of the box to allow the seismometer cable to exit.

- ♦ Seal the box joints properly:
 - For rigid foam without a foil coating, glue the joints using polystyrene adhesive or polyurethane resin, taking care not to leave any gaps.
 - For rigid foam with a foil coating, tape the joints with aluminium tape, taking care not to leave any gaps.
- ♦ Ensure there is a good seal between the bottom edge of the box and the pier. Adhesive weatherstripping that is 1.25cm (0.5 in.) thick creates a good seal.
- ♦ Ensure the thermal insulation box is held firmly in place by setting a weight on top of it. A brick works well for this purpose.
- ♦ Strain relieve the cable to the pier, close to the seismometer. Tie-wraps with tie-wrap anchors or a heavy object are effective tools for achieving strain relief.

3.5 Installing a Trillium 240 in the Insulating Cover

Use the following steps to install and align a Trillium 240 in the insulating cover:

1. Remove the precut gasket plugs as required for your installation (see the examples in [Figure 3-3 “Insulating cover installation options”](#) on page 15).
 - For standard installations, keep the alignment plugs as in example (A).
 - For modified installations, keep the centre plug and the alignment plugs as in example (C).
2. Draw a line on the installation surface parallel to east-west.
3. Place the gasket on the installation surface with the gasket alignment holes roughly centred over the east-west alignment line.

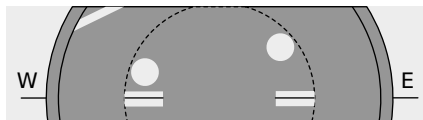

4. Place the seismometer in the gasket and align it (see [Section 3.2 “Best Practices for Aligning and Levelling a Trillium 240”](#) on page 12).
5. Connect the cable to the seismometer. The connector on all standard cables for Trillium seismometers is angled downward by about 30°, bringing the cable directly onto the gasket and preventing it from touching the cover.

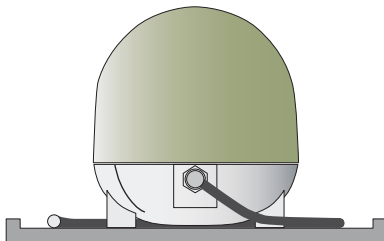

6. Pull the cable end through the cable outlet.

7. Place the cable on the gasket so it aligns to the V-groove in the bottom edge of the cover, approximately centring it between the edge of the gasket and the centre plug line.

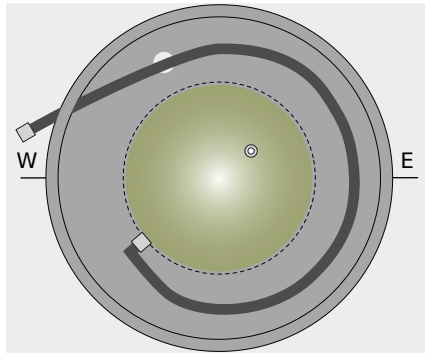

8. Orient the connector groove in the cover to the connector and place the cover over the seismometer.

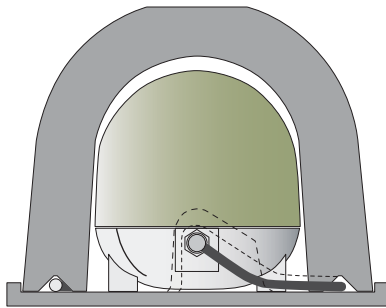

It is very important that the cover and gasket do not touch the seismometer or cable connector. A continuous air gap is required for the insulating cover to work properly.

9. To properly position the cover so that it is not touching the connector:
 - a) Lift the cover slightly above the gasket so that it does not drag when rotated.
 - b) Gently rotate the cover until it lightly touches the connector.
 - c) Rotate the cover by about 1 cm in the opposite direction and place it on the gasket.
10. Strain relieve the cable to the pier, close to the seismometer. Tie-wraps with tie-wrap anchors or a heavy object are effective tools for achieving strain relief.

Chapter 4

Post-Installation Activities

- ◆ [Grounding the Digitizer and Trillium 240](#)
- ◆ [Centring the Masses after Installation](#)
- ◆ [Installation Checklist](#)
- ◆ [Troubleshooting Your Installation](#)

4.1 Grounding the Digitizer and Trillium 240

The digitizer and seismometer cases must have a low-resistance path to ground for safety. However, directly earthing both instruments will result in a ground loop. When the digitizer and seismometer are far apart, differences in ground potential may cause spurious signals to appear unless the loop is broken. The solution is to earth the digitizer case and isolate the seismometer case.

Trillium seismometers have stainless steel adjustable feet which, when mounted directly onto dry rock or concrete, provide a relatively high resistance to ground. In wet environments it may be necessary to mount the seismometer on a plate of glass embedded in sand. For more details on earthing the digitizer and seismometer, refer to the user guide for your digitizer.

4.2 Centring the Masses after Installation

For best results, centre the masses in your Trillium 240 seismometers:

- ◆ Immediately after installing and levelling the seismometer.
- ◆ Again, at least 12 hours after installation, when the temperature of the Trillium 240 has fully equalized to the ambient temperature.

Centring the masses after temperature equalization allows the seismometer to tolerate subsequent ± 10 °C variations in ambient temperature without requiring recentring.

For more information on how and when to centre the masses in your Trillium 240, see [Chapter 7 "Centring the Masses."](#)

4.3 Installation Checklist

Use the following checklist to help you verify that you have completed all of the necessary steps in the installation of your Trillium 240.

- Installation surface is clear of debris.
- Trillium 240 is level.
- Trillium 240 is aligned to east-west or north-south.
- The feet of the Trillium 240 are locked.
- Trillium 240 serial number is noted.
- Cable is connected to the Trillium 240 and the digitizer.
- Cable is strain-relieved to the installation surface.
- Cable is not touching the Trillium 240 case.
- Thermal insulation is in place.
- Thermal insulation is not touching the Trillium 240 or cables.
- If using a rigid-foam insulating box, it is weighted down.
- Masses are centred after at least 12 hours of temperature equalization.

4.4 Troubleshooting Your Installation

It is normal to see spikes in the horizontal channels of a Trillium 240 as the seismometer settles after installation. However, if these spikes do not diminish after a few days, there may be a problem with the installation and the site should be visited to determine the cause of the spikes.

[Table 4-1](#) lists common types of noise, including horizontal spikes, that may occur with a Trillium 240 seismometer and reasons why the noise may be present.

Table 4-1 Types of noise and possible causes

Noise Type	Possible Cause
Spikes on the horizontal channels	<ul style="list-style-type: none"> ◆ The feet of the seismometer are not locked. ◆ There is a force pulling on the cable. ◆ There is something touching the sides of the seismometer. ◆ There are forces, such as wind, acting on the seismometer or the installation surface.
Continuous low frequency wander (random noise, larger on horizontal channels)	<ul style="list-style-type: none"> ◆ Insulation is missing or not well sealed, allowing drafts to blow over the seismometer.
Spikes on the vertical channel	<ul style="list-style-type: none"> ◆ Usually due to electrical system noise. For example, power supply noise from a battery charging circuit, or interference from a strong magnetic or radio source that is nearby.

Part 2

Operation

- ◆ Input and Output Signals
- ◆ Using a Nanometrics Digitizer with a Trillium 240
- ◆ Centring the Masses
- ◆ Setting Up Serial Port Communications

Chapter 5

Input and Output Signals

- ◆ [Digital Control Input Signals](#)
- ◆ [UVW and XYZ Output Signals](#)
- ◆ [Calibration Input Signals](#)
- ◆ [State-of-Health Output Signals](#)
- ◆ [Power Consumption](#)

5.1 Digital Control Input Signals

Trillium 240 seismometers have five digital control input signals: MC/RX, UVW/TX, U_CALEN, V_CALEN, and W_CALEN.

Each input is optically isolated from the input voltage, the output signals, and the calibration input signals. Therefore, signals applied to these pins must be referenced to DGND rather than \pm PWR or AGND.

All of the control input signals are active-high. Specifically, any voltage greater than 3.5 V at a current greater than 0.1 mA enables the relevant functionality, while any voltage less than 1 V or a high impedance disables it. All inputs can tolerate at least \pm 15V except for UVW/TX which can tolerate voltages from -7 V to +15 V.

5.2 UVW and XYZ Output Signals

To account for the source impedance, see [Table 10-1 "Ground motion response nominal parameters"](#) on page 49. A control signal switches the Trillium 240 output signal to either UVW output mode or XYZ output mode. The "natural" output is UVW where the outputs represent the actual motion of the three sensor component masses. The "conventional" seismometer output is XYZ where the outputs represent horizontal and vertical motion.

See [Table 5-1](#) for the polarities of the XYZ outputs and the correspondence of each to the directions of the compass.

Table 5-1 Axis orientation and polarity of XYZ outputs

Axis	Orientation	Positive Voltage
X	east-west	represents case motion to the east
Y	north-south	represents case motion to the north
Z	vertical	represents upward case motion

The seismometer will respond to changes in the type of output signal within 4 s. To select the

- ♦ UVW outputs, pull the UVW/TX pin high.
- ♦ XYZ outputs, leave the UVW/TX pin floating or set it to 0 V.



The UVW/TX input control signal is disabled when the seismometer is transmitting through a serial port because this pin is used as the RS-232 serial TX output signal. For more information on serial port communication with a Trillium 240, see [Chapter 8 "Setting Up Serial Port Communications."](#)

To understand the difference between the UVW and XYZ outputs, see [Figure 5-1](#). By design, the Trillium 240 axes are identical and sense motion in orthogonal directions. The U axis is aligned with the east-west axis when projected into the horizontal plane.

Figure 5-1 Trillium 240 axis orientation

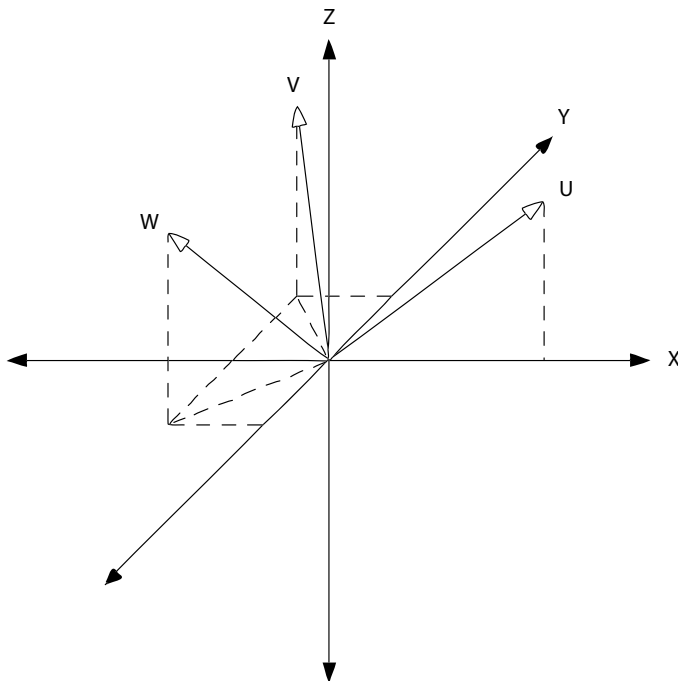

This arrangement results in the following transformation equations:

$$\begin{bmatrix} u \\ v \\ w \end{bmatrix} = \frac{1}{\sqrt{6}} \cdot \begin{bmatrix} 2 & 0 & \sqrt{2} \\ -1 & \sqrt{3} & \sqrt{2} \\ -1 & -\sqrt{3} & \sqrt{2} \end{bmatrix} \cdot \begin{bmatrix} x \\ y \\ z \end{bmatrix} \quad (\text{EQ 1})$$

$$\begin{bmatrix} x \\ y \\ z \end{bmatrix} = \frac{1}{\sqrt{6}} \cdot \begin{bmatrix} 2 & -1 & -1 \\ 0 & \sqrt{3} & -\sqrt{3} \\ \sqrt{2} & \sqrt{2} & \sqrt{2} \end{bmatrix} \cdot \begin{bmatrix} u \\ v \\ w \end{bmatrix} \quad (\text{EQ 2})$$

The first equation is implemented mechanically in the Trillium 240 through the orientation of the individual axes. The second equation is implemented electronically when the Trillium 240 is in XYZ mode.

Alternatively, seismic data can be digitized with the Trillium 240 seismometer in UVW mode and the transformation to horizontal and vertical signals being implemented when the data are processed. This method allows for studies and calibrations where both UVW and XYZ data are required.

5.3 Calibration Input Signals

Calibration input signals are provided to allow for relative calibration of the Trillium 240 across frequency and over time.

Since the Trillium 240 is a symmetric triaxial seismometer, calibration is best performed on the individual axes (UVW) rather than the horizontal and vertical outputs (XYZ). Individual axis outputs can be digitized by placing the seismometer in UVW mode. For instruction on how to set a Trillium 240 to UVW mode, see [Section 5.2 “UVW and XYZ Output Signals”](#) on page 23.

Each axis has a separate calibration enable signal: U_CALEN, V_CALEN, W_CALEN. All of the axes use a common calibration input signal, CAL_SIG. See [Table 10-2 “Calibration input response nominal parameters”](#) on page 50 for sensitivity information.

5.4 State-of-Health Output Signals

Mass position output signals U_MP, V_MP, and W_MP are provided to monitor the effect of tilt and temperature on the spring that sets the rest position of the boom. As with the calibration signals, these signals represent the state of the individual axes (UVW) rather than the horizontal and vertical outputs (XYZ). Zero the mass positions by initiating automated mass centring, which uses stepper motors to precisely tension the spring. See [Section 7.2 “Choosing When to Initiate Mass Centring”](#) on page 32 for more information on centring the masses based on the status of these signals.

If any of the mass positions are approaching ± 3.5 V, mechanical recentring should be initiated. Follow the procedure in [Section 7.3 “Initiating Mass Centring Using a Standard Cable and Digitizer”](#) on page 33.

5.5 Power Consumption

Following are power consumption scenarios typical of Trillium 240 seismometers:

- ♦ Under normal operation (the Trillium 240 is level and well centred, there is a low seismic signal, the Trillium 240 has settled for at least 30 minutes, and serial transmit is disabled), power consumption is approximately 650mW.

- ♦ On start-up, power consumption may briefly surge to 4.5W.

Power consumption above normal quiescent, after the initial power-on inrush, is roughly proportional to the output signal.

If the Trillium 240 is not centred or has not yet settled, the output signals will be at the maximum, and power consumption may be as high as 3 W.

- ♦ For a settled, centred, and level Trillium 240, a seismic signal that approaches the maximum clip level of the seismometer may draw as much as a 2 W peak (the average power consumption would be much lower).
- ♦ Mass centring draws up to an incremental 2 W of additional power while the motors are operating.



For long cables, account for the resistive voltage drop due to the cable length and, if necessary, increase the voltage at the source.

For example, 50 m of 24 AWG wire has a resistance of 4.2 Ω in each direction. Therefore the voltage drop due to the possible 500 mA startup inrush at 9 V would be 4.2 V, and the power supply should be able to briefly supply 13.2 V for this length of cable. The supply should also be able to sustain a 2 W peak output at a voltage that guarantees the seismometer receives 9 V.

In the example above, the peak current would be 220 mA at 9 V, and the voltage drop would be 1.9 V, so the supply must be able to provide 220 mA at 10.9 V to reliably power the seismometer for maximum seismic signals when using a 50 m cable.

Chapter 6

Using a Nanometrics Digitizer with a Trillium 240

- ♦ [Using a Taurus Portable Seismograph with a Trillium 240](#)
- ♦ [Using a Trident Digitizer with a Trillium 240](#)
- ♦ [Increasing System Sensitivity](#)

6.1 Using a Taurus Portable Seismograph with a Trillium 240

Refer to the user guide for your Taurus portable seismograph for complete instructions on using it with a seismometer. The instructions that follow are a guide to selecting the default configuration for a Trillium 240 on your Taurus, using the Taurus graphical user interface on either the Taurus display screen or through a Web browser. Nanometrics cable 16169-nM or cable 16163-nM (where n is the length of the cable in metres) can be used to connect a Trillium 240 to a Taurus. See [Table 1-1 "List of Trillium 240 optional equipment"](#) on page 5 for descriptions of these cables.

If you are using a version 3.x Taurus

1. Log into the Taurus with either the tech or central user account.
2. Select **Configuration > Sensor Library**.
3. Select **Default Trillium 240** from the list of seismometers.
4. Select **Apply**.
5. Select **Commit**.

If you are using a version 2.x Taurus

1. Log into the Taurus with either the tech or central user account.
2. Select **Advanced Configuration** from the **Status** menu.
3. Select **Browse** and navigate to the Trillium240.cfg file in the **sensors** folder of the Taurus software CD.
4. Select **Apply**.
5. Select **Commit**.

6.2 Using a Trident Digitizer with a Trillium 240

Refer to the user guide for your Trident digitizer for complete instructions on using it with a seismometer. Nanometrics cable 16169-nM or cable 16163-nM (where n is the length of the cable in metres) can be used to connect a Trillium 240 to a Trident digitizer. See [Table 1-1 "List of Trillium 240 optional equipment"](#) on page 5 for descriptions of these cables.

Following are instructions for configuring your Trident and NaqsServer to work with a Trillium 240 seismometer.

1. Match the settings on the **Configuration** tab of Nanometrics UI to those in the following table.

Nanometrics UI Configuration Tab		Value	Notes
Section	Setting		
Front End	Input Range	40 Vpp	
Sensor Control	High Voltage Level	+5 V	
	Calibration Mode	Voltage (active high)	
	Line 1 Level	Low	Low is equivalent to XYZ mode and High is equivalent to UVW mode.
	Line 2 Level	Low	Pulse Line 2 high for at least 1 s to initiate automatic mass centring.
	Line 3 Level	Not used	

2. Ensure the NaqsServer Naqs.stn file contains the following information:

```
[ Sensor ]
Typename = Trillium240 // predefined sensor - all fields mandatory
Model = Trillium240 // name of this prototype - may be same as model
SensitivityUnits = M/S // sensor model name
Sensitivity = 4.784e+8 // units of ground motion: M, M/S or M/S**2
SensitivityFreq = 1.0 // counts per unit of ground motion (System Sensitivity)
CalibrationUnits = VOLTS // Frequency at which sensitivity is correct
CalCoilResistance = 9200 // calibration input units: VOLTS or AMPS
CalCoilConstant = -95.54 // calibration coil resistance in ohms
CalEnable = -1 // calibration units per m/s/s
CalRelay = 0 // digital enable signal for calibration
MassCenterEnable = 2 // analog relay for calibration (0 = use channel number)
MassCenterDuration = 2 // digital enable signal for mass centering
CalSource = Trident // duration of mass centering signal in seconds (optional)
// gives the source of the Cal signal
```

6.3 Increasing System Sensitivity

If increased system sensitivity is required for either the Taurus or Trident, decrease the digitizer input range and increase the sensitivity in the Naqs.stn file. Use [Table 6-1](#) as a guide.



Increasing the sensitivity of a digitizer by decreasing the input range can cause the digitizer to clip. For example, there is a high potential for clipping if the digitizer input is reduced to 2 Vpp and the Trillium 240 has a 40 Vpp output.

Table 6-1 Increasing system sensitivity

Digitizer Input Range	Digitizer Software Gain	Digitizer Sensitivity	Trillium 240 Sensitivity	System Sensitivity (Counts/(m/s))
40 Vpp	1	0.4 count / μ V	1196 V·s/m	4.784e+8
16 Vpp	1	1 count / μ V	1196 V·s/m	1.196e+9
8 Vpp	1	2 count / μ V	1196 V·s/m	2.392e+9
4 Vpp	1	4 count / μ V	1196 V·s/m	4.784e+9
2 Vpp	1	8 count / μ V	1196 V·s/m	9.568e+9

Chapter 7

Centring the Masses

- ◆ [About Mass Centring](#)
- ◆ [Choosing When to Initiate Mass Centring](#)
- ◆ [Initiating Mass Centring Using a Standard Cable and Digitizer](#)
- ◆ [Initiating Mass Centring using a Serial Cable and Laptop](#)

7.1 About Mass Centring

Trillium 240 seismometers have an automated mechanical mass centring capability that uses a precision stepper motor to centre the boom of the pendulum of each axis exactly at the null point. The motor adjusts the tension on the spring supporting the boom to compensate for tilt and changes in ambient temperature. After initial mass centring (spring adjustment), the seismometer keeps the pendulum at the null point by passing current through a force feedback coil. This allows it to accommodate a certain range of tilt and temperature without recentring, as specified below.

Trillium 240 seismometers have three analog voltage outputs representing the DC currents applied to each of the three channel feedback coils. These are the mass position outputs which cover a range of ± 4 V. Zero volts means the moving mass would be perfectly balanced if there was no force feedback. An offset in the mass position voltage means that the equilibrium position of the mass has moved off centre and a small DC feedback current is being applied to hold the mass at its centre operating point. The Trillium 240 is not subject to any significant degradation in performance until one or more mass positions exceed approximately ± 3.5 V. This value represents the limit of available current to the force feedback coil. When this limit is exceeded, the main velocity output signal will drift to the rail and cease to provide useful information about ground motion.

The mass centring process itself introduces large glitches with the ground motion signal for about 1 minute while the axes are rebalanced. Therefore, to prevent data loss, you should only recentre the seismometer when necessary. The recommended best practice regarding mechanical mass centring is to periodically check the three axis mass positions (analog signals U_MP, V_MP, and W_MP, referenced to AGND) and initiate mass centring if any are approaching ± 3.5 V.

The mass positions can drift over time, for two reasons:

a) Tilt

Circumstances such as compaction of soil, changes in moisture, frost heaving, or the expansion of structures in hot sun may cause the ground under the seismometer to tilt. The Trillium 240 has a tilt range of $\pm 0.03^\circ$ without recentring. This is more than sufficient for a permanent vault installation. However care must be taken in temporary field deployments to ensure that the ground is stable under the seismometer.

b) Temperature

The Trillium 240 has a temperature range of ± 10 °C without recentring. Since the seismometer itself has a large heat capacity (thermal mass) and is normally installed below ground level, with insulation, it will not become decentred due to day-to-night temperature cycling. However, seasonal temperature changes can cause the seismometer to become decentred. Therefore, mass positions may need to be checked on a monthly basis, depending on the climate.

These two phenomena are easily distinguished. Simply speaking, the effects of temperature appear in the sum of all of the mass positions, while the effects of tilt appear in the differences between mass positions. You can use the equations in [Section 5.2 "UVW and XYZ Output Signals"](#) on page 23 to convert UVW to XYZ mass positions. Changes in the Z mass position correspond to changes in internal temperature, while changes in the X and Y mass positions correspond to tilt towards the east and north, respectively.

Nanometrics systems and software allow the mass positions to be monitored and recentred remotely. Alternatively the Taurus portable seismograph can be configured to automatically recentre the seismometer whenever the mass position exceeds a preset threshold. See [Chapter 6 "Using a Nanometrics Digitizer with a Trillium 240"](#) for information on setting up a Taurus portable seismograph or Trident digitizer to work with a Trillium 240.

7.2 Choosing When to Initiate Mass Centring

Following are circumstances when you should mechanically centre the masses in Trillium 240 seismometers:

- ♦ Immediately following installation and levelling.
- ♦ Twelve or more hours after installation, when the temperature of the Trillium 240 has fully equalized to the ambient temperature.
- ♦ When the voltage of any of the three axis mass positions (analog signals U_MP, V_MP, and W_MP, referenced to AGND) approach ± 3.5 V.

It is best to centre the masses when:

- ♦ The ambient temperature is roughly in the centre of its expected range, allowing the seismometer to use the full ± 10 °C range before mechanical recentring will be required due to temperature change again. For example, if temperature maxima are reached in summer and winter, it is best to recentre the masses in spring or fall.
- ♦ An interruption of good-quality seismic data can be tolerated, as mechanical mass recentring has temporary effects on the output signal.

7.3 Initiating Mass Centring Using a Standard Cable and Digitizer

The following instructions explain how to initiate mass centring using a standard cable (see [Table 1-1 “List of Trillium 240 optional equipment”](#) on page 5 for information on the cable options offered by Nanometrics) and a Nanometrics Taurus portable seismograph, a Nanometrics Trident digitizer, or a third party digitizer. The time for the operation to complete varies from a few seconds up to 5 minutes, but typically takes less than 1 minute.

1. Check the voltage readings on the mass position outputs for each of the three channels (signals U_MP, V_MP, and W_MP, referenced to AGND) to determine whether mass centring is required. If any of the mass position outputs exceed ± 3.5 V, continue with the mass centring procedure.
 -  If you have a Taurus, check the mass position status on the **Sensor** page. If you have a networked Trident, check the mass position status on the Nanometrics UI **Trident > Operation > Instrument** page or on the NaqsView **View > Mass Position and Centering** page. See the user guides for these products for more information.
2. Initiate mass centring using the option that best meets your hardware and software configuration:
 - a) If you are using a Taurus, configure the Taurus for a Trillium 240 (see [Section 6.1 “Using a Taurus Portable Seismograph with a Trillium 240”](#) on page 27) and select **Centre**  on the **Sensor** page using the Taurus graphical user interface on either the Taurus display screen or through a Web browser. See the Taurus user guide for more information on using this feature.
 - b) If you have a networked Trident and a laptop equipped with NaqsServer and NaqsView (see [Section 6.2 “Using a Trident Digitizer with a Trillium 240”](#) on page 28), select **Mass Center**  on the NaqsView **View > Mass Position and Centering** page. See the Trident and NaqsView user guides for more information.
 -  NaqsView requires a password to connect to NaqsServer. You can find this password in the Naqs.ini file, which is located in the /user folder of your NaqsServer installation location.
 - c) If you have a networked Trident with Nanometrics UI, set Line 2 Level to High and pull the MC/RX pin high, referenced to DGND (pin R), for at least 1 s. See the Trident and Nanometrics UI user guides for more information.
 - d) If you have a third-party digitizer, pull the MC/RX pin high, referenced to DGND (pin R), for at least 1 s.
3. Check the voltage readings on the mass position outputs again to confirm that the masses are now within the ± 0.3 V range.



The Trillium 240 automatically changes to SP mode during the centring operation, and is automatically returned to its previous state when the centring operation is complete.

7.4 Initiating Mass Centring using a Serial Cable and Laptop

Another option for initiating mass centring is through a direct serial connection between a Trillium 240 and a laptop. [Chapter 8 "Setting Up Serial Port Communications"](#) provides instruction on configuring the serial connection and a list of the serial commands.

Once the serial connection is established and the serial port is configured, issue the following commands in the RS-232 digital interface to check the status of the mass position outputs and centre the mass.

1. Issue a `He1p` command to activate serial communications.
2. Issue an `SOH` command to check the voltage readings on the mass position outputs for each of the three channels (signals `U_MP`, `V_MP`, and `W_MP`, referenced to `AGND`) to determine whether mass centring is required. If any of the mass position outputs are approaching ± 3.5 V, mechanical mass centring should be initiated.
3. Issue a `Center` command to begin centring the masses.
4. Issue another `SOH` command to confirm that the masses are now within ± 0.3 V.

Chapter 8

Setting Up Serial Port Communications

- ♦ [Connecting to and Configuring the Serial Port](#)
- ♦ [Serial Port Commands](#)

8.1 Connecting to and Configuring the Serial Port

Use the following steps to connect the Trillium 240 to the serial port of a communications device (such as a computer) and configure serial port communications.

1. Connect an appropriate RS-232 communications device to the seismometer by connecting its TX pin to the MC/RX signal (pin C) and its RX pin to the UVW/TX signal (pin D).



Be sure to take appropriate precautions for signal shielding and grounding to avoid introducing unwanted noise into the seismometer or onto adjacent signal wires in the cable, or the seismic signal from the seismometer may become noisy.

2. Set the serial port on the communicating device to use this configuration:
 - Speed: 9600 baud
 - Data bits: 8
 - Parity: None
 - Stop bits: 1
 - Flow control: Xon/Xoff
3. If you are using a terminal emulator program, enable these settings:
 - Echo typed characters locally: The Trillium 240 seismometer serial port does not echo received characters on its transmit port.
 - Send line ends with line feeds (or equivalent): The serial port expects all commands to be terminated with the "carriage return" character (ASCII 0x0D).
4. Once the seismometer is powered up and an appropriate serial device connected as above, send the characters `Tx<CR>` (<CR> denotes the carriage return character). Note that the serial commands are not case-sensitive; `Tx`, `TX`, and `tx` are equivalent. After a delay of 3 seconds the seismometer will enable the UVW/TX output and transmit `Serial Transmit Enabled<LF><CR>`.

- To view help on the commands, send the help command (`Help<CR>`) to get the seismometer to transmit a help page, displaying the various commands and syntax.

8.2 Serial Port Commands

The following table describes each of the serial port commands.

Table 8-1 Serial port commands

Command	Description
Help - Repeat this menu (also turns on Serial TX)	Use the <code>Help</code> command to view the list of commands. The first line identifies the firmware version in use, and whether it is Program A or Program B. The <code>Help</code> command also turns on the TX signal if it has not already been turned on (after a delay of three seconds). It is the only command other than <code>Tx</code> that will enable the seismometer's serial transmit signal.
Tx - Enable the Serial Transmit Signal	The <code>Tx</code> command turns on the seismometer's serial transmit signal (signal UVW/TX, pin D) after a delay of three seconds, and sends the message <code>Serial Transmit Enabled<LF><CR></code> . The serial transmit port stays enabled until turned off by the <code>TxOff</code> command or by cycling the power to the seismometer. In this mode, the UVW/TX pin must not be used as an input pin for UVW mode.
TxOff - Disable the Serial Transmit Signal	The <code>TxOff</code> command turns off the seismometer's serial transmit signal (signal UVW/TX, pin D) and then waits three seconds. After the three-second delay, this pin will be interpreted as the UVW mode input pin.
Upload - Upload software to the alternate program	Caution: DO NOT use the <code>Upload</code> command unless specifically directed to do so by Nanometrics Technical Support. This command erases the firmware in the alternate partition. The <code>Upload</code> command uploads a new version of firmware to the firmware partition (A or B) that is not currently running.
Switch - Switch to the alternate program	There are two instances of firmware loaded in the Trillium 240 seismometer, which can be the same version or different versions, one loaded in partition A, the other in partition B. The seismometer will run the firmware from the default partition on power up. Use the <code>switch</code> command to immediately switch to the firmware in the other partition. It does not change which partition is the default, meaning that when the seismometer is power cycled, it will start up in the default partition. For example, if the default partition is B and the <code>Switch</code> command is executed, then partition A firmware is run immediately. When the seismometer is powered off and then on again, it then switches back to running Partition B firmware. ♦ Use the <code>Checksum</code> command to ensure there is valid code in both partitions before switching.

Table 8-1 Serial port commands

Command	Description
Default - Set the current program as default	Use the <code>Default</code> command to set the running firmware partition to be the default partition loaded at power up. For example, if the seismometer is running partition A by default on power up, to change to running partition B instead, the procedure is: <ol style="list-style-type: none"> 1. Execute the <code>SOH</code> command to verify that partition A is running. 2. Execute the <code>Checksum</code> command to verify that there is valid code in both partitions. 3. Execute the <code>Switch</code> command to change to running partition B, and the <code>SOH</code> command to verify that the new firmware is running. 4. Execute the <code>Default</code> command to set partition B to be the default on power up.
Reboot - Reboot the instrument	Use the <code>Reboot</code> command to restart the firmware.
GetInfo - Get factory configuration information ReadFC - Read factory calibration parameters	Use the <code>GetInfo</code> and <code>ReadFC</code> commands to read factory information stored in the Trillium 240 seismometer. Factory configuration information includes model, version, and serial numbers; and other factory information for the unit, axes, and various circuit boards in the seismometer. This information is primarily used by Nanometrics Technical Support. Factory calibration parameters may include such information as measured sensitivity and transfer function.
WriteUC - Write user calibration parameters	Use the <code>WriteUC</code> command to upload calibration results from a text file.
ReadUC - Read the user calibration parameters	Use the <code>ReadUC</code> command to display calibration information stored using the <code>WriteUC</code> command.

Table 8-1 Serial port commands

Command	Description
SOH - Report state-of-health	<p>Use the SOH command to view state-of-health information as listed below.</p> <pre data-bbox="748 327 1409 667"> <SOH> <Manufacture>"Nanometrics, Inc."</Manufacture> <Product>"Trillium Firmware"</Product> <Version>3.30</Version> <Temperature>26.22</Temperature> <Mass>U=0.030 V=0.497 W=0.063</Mass> <Adc>U=14 V=225 W=29</Adc> <Modes>Period=Long Channel=XYZ</Modes> <Positions>U=380 V=-66 W=-110</Positions> <Zeros>U=0 V=0 W=0</Zeros> <Range>U=7043 V=7371 W=7151</Range> </SOH> </pre> <ul style="list-style-type: none"> ♦ <Version> – The version of the firmware that is currently running. ♦ <Temperature> – The temperature near the main electronics circuit board, which is located in a chamber near the top of the seismometer. The temperature of the axes is probably different from this temperature. ♦ The mass positions for each axis (U, V, W). These are reported in two forms: <ul style="list-style-type: none"> • <Mass> – decimal numbers with a ± 4.2 range that roughly corresponds to the output voltage at the U_MP, V_MP, and W_MP signals. • <ADC> – proportional integer numbers with a range of ± 1900. The <ADC> number is about 452 times the <Mass> decimal number. ♦ <Modes> – The seismometer modes are reported, including whether the seismometer is in long period or short period mode, and whether the seismic signals are output in XYZ or UVW mode. ♦ The <Range>, <Positions>, and <Zeros> numbers pertain to the mass recentring stepper motors: <ul style="list-style-type: none"> • The <Range> number is the full range in steps the mass positioning stepper motor can traverse between the two optical limit switches. This is measured and set at the factory for each axis. • The <Positions> number is the current position of the stepper motor relative to the midpoint of the total range. A number close to zero means the mass positioning mechanism is near the midpoint of the range and has lots of room for further adjustment. A positive or negative number close to half the <Range> number means the mass positioning mechanism is near to the limit of its adjustment range. <p>The <Zeros> number is the position of the stepper motor which corresponds to the seismometer being level. If the <Position> number is close to the <Zeros> number for all axes, the seismometer is close to nominally level. The <Zeros> number is set at the factory for each axis.</p>

Table 8-1 Serial port commands

Command	Description
<p>ShortPer - Set sensor to short period mode</p> <p>LongPer - Set sensor to long period mode</p>	<p>Use the <code>ShortPer</code> and <code>LongPer</code> commands to set the electronic mass centring response of the seismometer to short period or to long period respectively.</p> <ul style="list-style-type: none"> Short period is used when mechanically recentring the masses, and is automatically invoked when the mass recentring is initiated. (The prior mode is restored when mass centring completes.) Long period mode is the normal mode for collecting seismic data, and is essential to obtain the low frequency broadband performance. <p>Short period mode is useful to see the mass positions respond quickly (signals <code>U_MP</code>, <code>V_MP</code>, <code>W_MP</code>, or the <code>SOH <Mass></code> or <code><ADC></code> values) when the seismometer is being levelled. In long period mode these numbers ramp very slowly, and so, care must be taken to not be misled by apparently centred values when in fact the seismometer is not centred. In short period mode, these numbers respond within a second. The seismometer always powers up in long period mode.</p> <p>Long period is the normal response for a 240 second lower corner frequency.</p>
<p>SetXYZ - Set sensor to XYZ mode</p> <p>SetUVW - Set sensor to UVW mode</p>	<p>Use the <code>SetXYZ</code> and <code>SetUVW</code> commands to set the seismic output signals to the conventional XYZ (horizontal and vertical) mode, or to the “natural” UVW mode in which the output of each axis is given directly. XYZ mode is the default. Note that this mode is also set by the UVW/TX input line when the seismometer is not in Serial Transmit mode. The seismometer responds to whichever command (serial port or control line) last signalled a change.</p>
<p>Center - Centre all masses or (u, v, w)</p>	<p>You can use the <code>Center</code> command with or without parameters:</p> <ul style="list-style-type: none"> Without parameters, <code>Center</code> initiates mass centring for all channels, which can also be initiated by pulling the MC/RX pin high for at least 1 second (referenced to DGND). With a parameter (u, v, or w), <code>Center</code> will centre the specified axis without disturbing the other axes; for example, <code>Center v</code> centres the V axis only.
<p>Checksum - Print checksum values for both program A and B</p>	<p>Use the <code>Checksum</code> command to check the firmware checksums of both partitions and what they should be. This is useful to ensure there is valid code in each partition (for example, before switching to the alternate firmware partition).</p>

Part 3

Reference

- ◆ Specifications
- ◆ Transfer Function
- ◆ Connector and Cables
- ◆ Alignment Features and Dimensions
- ◆ Glossary
- ◆ About Nanometrics

Chapter 9

Specifications

- ♦ [Technology](#)
- ♦ [Interface](#)
- ♦ [Physical](#)
- ♦ [Power](#)
- ♦ [Performance](#)
- ♦ [Environmental](#)

9.1 Technology

Table 9-1 Technology specifications

Topology	Symmetric triaxial
Feedback	Coil-magnet force feedback with capacitive transducer
Mass Centring	Automatic mechanical recentring, can be remotely initiated
Levelling	Integrated bubble level, adjustable locking levelling feet
Alignment	Vertical scribe marks for east-west 5/16 in. diameter holes on north-south axis for alignment rods

9.2 Interface

Table 9-2 Interface specifications

Connector	19-pin MIL-C-26482, mounted on base
Velocity output	Selectable XYZ (east, north, vertical) or UVW mode 40 Vpp differential
Mass position output	Three independent ± 4.0 V outputs for UVW
Calibration input	Remote calibration in XYZ or UVW mode One voltage input for all channels Three separate control signals to enable U, V, or W channels
Control input	Isolated active-high referenced to DGND
Serial port	RS-232 compatible For instrument control and retrieval of configuration information

9.3 Physical

Table 9-3 Physical specifications

Diameter	25 cm
Height	26.6 cm without levelling feet 28.6 cm with levelling feet fully retracted 29.5 cm with levelling feet fully extended
Weight	14 kg
Handling	Detachable carrying handle on case
Parasitic resonances	None below 150 Hz

9.4 Power

Table 9-4 Power specifications

Supply voltage	9 V to 36 V DC isolated input at connector
Power consumption	See Section 5.5 "Power Consumption" on page 26 for typical power consumption scenarios
Protection	Reverse-voltage protected Self-resetting over-current protection No fuse to replace

9.5 Performance

Table 9-5 Performance specifications

Self-noise	See Figure 10-2 "Trillium 240 self-noise" on page 51
Sensitivity	Within $\pm 0.5\%$ of nominal. See Table 10-1 "Ground motion response nominal parameters" on page 49
Bandwidth	-3 dB points are 244 s and 223 Hz
Transfer function	<ul style="list-style-type: none"> ◆ Lower corner poles within $\pm 0.5\%$ of nominal provided ◆ High-frequency poles and zeros within $\pm 5\%$ of nominal provided ◆ See Figure 10-1 "Bode plot for Trillium 240 seismometers" on page 48
Clip level	15 mm/s peak-to-peak differential up to 1.5 Hz (see Figure 10-3 "Trillium 240 performance" on page 52)
Lower corner damping relative to critical	0.707
Output impedance	$2 \cdot 150 \Omega \pm 1\%$
Temperature	$\pm 10^\circ\text{C}$ without recentering
Tilt	Operational tilt range $\pm 1.5^\circ$

9.6 Environmental

Table 9-6 Environmental specifications

Operating temperature	–20°C to 50°C
Storage temperature	–40°C to 70°C
Pressure	Enclosure optimized to be insensitive to atmospheric variations
Humidity	0% to 100%
Shock	20g half sine, 5ms without damage, 6 axes No mass lock required for transport
Weather resistance	Rated to IP68 and NEMA 6P for outdoor use, dust, and immersion resistance

Chapter 10

Transfer Function

- ◆ [Frequency Response](#)
- ◆ [Self-Noise](#)

10.1 Frequency Response

Figure 10-1 “Bode plot for Trillium 240 seismometers” on page 48 is a bode plot that shows the nominal ground motion, calibration input circuit, and combined calibration response for Trillium 240 seismometers. Although the frequency response does vary for Trillium 240 seismometers with serial numbers in the ranges of 0 to 399 and 400 and above, the bode plot is almost identical for all Trillium 240 seismometers, regardless of serial number.

In this figure:

- ♦ The nominal ground motion frequency response of the seismometer is shown as a solid red line.
- ♦ The calibration input circuit response is shown as a dash-dotted green line and behaves effectively as a simple low-pass circuit in series with the ground motion response.
- ♦ During calibration, the sensor calibration response is the combination of the two lines referenced above and is shown as a dashed blue line.

Figure 10-1 Bode plot for Trillium 240 seismometers

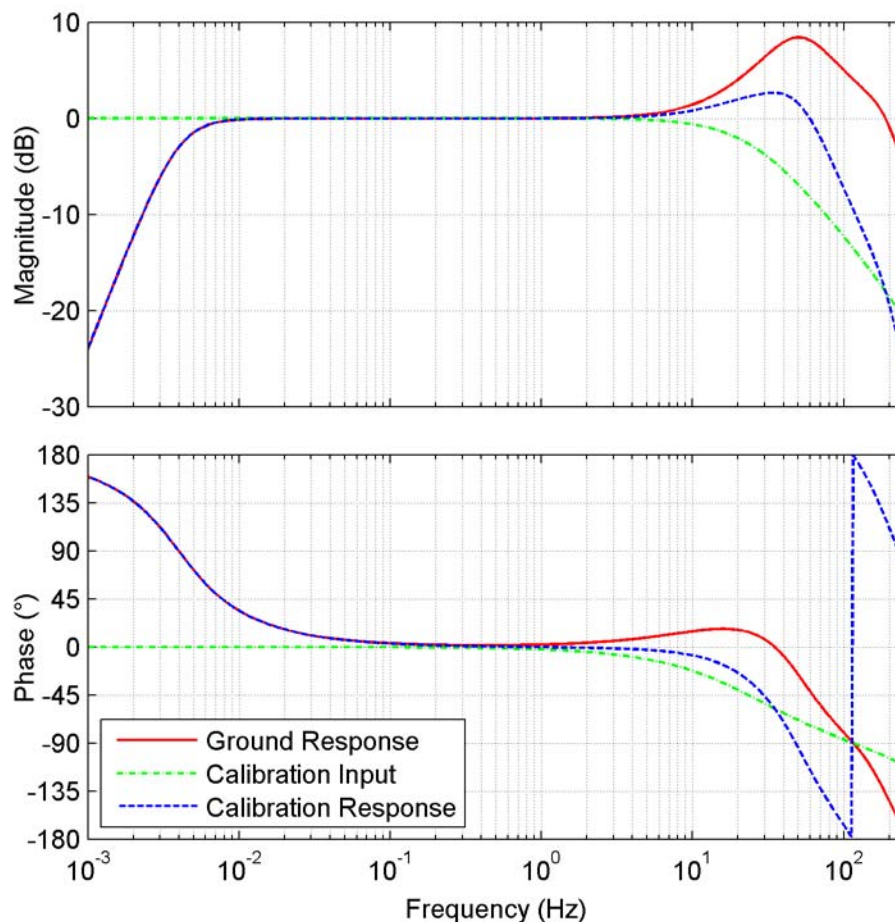

Table 10-1 provides the ground motion response nominal parameters. The ground motion response has -3 dB corners at 244.2 s and 223 Hz. The ground motion sensitivity at f_0 specified in Table 10-1 assumes an infinite input impedance at the digitizer. For digitizers with low input impedance, it will become necessary to account for the fact that source impedance of the differential outputs is 300 Ω , ± 1 percent (150 Ω for each output).

Table 10-1 Ground motion response nominal parameters

Symbol	Parameter	Nominal Values		Units
		Serial Numbers 0 - 399	Serial Numbers 400 and Above	
z_n	Zeros	0	0	rad/s
		0	0	
		-90.0	-91.66	
		-164.2	-160.1	
		-3203	-3207	
p_n	Poles	$-0.01813 \pm 0.01803i$	$-0.01770 \pm 0.01760i$	rad/s
		-124.9	-126.7	
		$-197.5 \pm 256.1i$	$-192.0 \pm 259.1i$	
		$-569 \pm 1150i$	$-557.7 \pm 1143i$	
k	Normalization factor	4.532×10^5	4.517×10^5	(rad/s) ²
f_0	Normalization frequency	1	1	Hz
S	Ground motion sensitivity at f_0	1196.6	1168.2	V·s/m

The seismometer sensitivity (S), poles (p_n), and zeros (z_n) define the transfer function according to this equation:

$$F(s) = S \cdot k \cdot \frac{\prod_n (s - z_n)}{\prod_n (s - p_n)} \quad (\text{EQ 1})$$

Where the normalization factor (k) is defined by

$$k = \frac{1}{\frac{\prod_n (i \cdot 2 \cdot \pi \cdot f_0 - z_n)}{\prod_n (i \cdot 2 \cdot \pi \cdot f_0 - p_n)}} \quad (\text{EQ 2})$$

and is given for informational purposes only.

The calibration input response nominal parameters are given in [Table 10-2](#).

Table 10-2 Calibration input response nominal parameters

Symbol	Parameter	Nominal Values		Units
		Serial Numbers 0 – 399	Serial Numbers 400 and Above	
z_n	Zeros			rad/s
p_n	Poles	-164.2 -3203	-160.1 -3207	rad/s
k	Normalization factor	5.263×10^5	5.138×10^5	(rad/s) ²
f_0	Normalization frequency	1	1	Hz
S	Calibration input sensitivity at f_0	0.010468	0.010467	(m/s ²)/V

The calibration input poles effectively cancel the corresponding zeros in the ground motion response during calibration. Thus the nominal parameters of the combined calibration response are as shown in [Table 10-3](#).

Table 10-3 Combined calibration response nominal parameters

Symbol	Parameter	Nominal Values		Units
		Serial Numbers 0 – 399	Serial Numbers 400 and Above	
z_n	Zeros	0 0 -90.0	0 0 -91.66	rad/s
p_n	Poles	-0.01813 ± 0.01803i -124.9 -197.5 ± 256.1i -569 ± 1150i	-0.01770 ± 0.01760i -126.7 -192.0 ± 259.1i -557.7 ± 1143i	rad/s
k	Normalization factor	2.385×10^{11}	2.321×10^{11}	(rad/s) ⁴
f_0	Normalization frequency	1	1	Hz
S	Combined calibration sensitivity at f_0	12.525	12.227	rad/s

When a measured electrical calibration result is to be used to convert the seismometer output signals to ground motion, the result must be divided by the nominal calibration input. In practice this means simply adding the nominal poles from [Table 10-2 "Calibration input response nominal parameters"](#) on page 50 to the set of measured zeros.



The units of the combined calibration response are rad/s because the calibration input produces an equivalent acceleration, while the seismometer passband is flat to velocity. Therefore, to determine the expected gain for a sinusoidal calibration, you must divide the sensitivity listed in [Table 10-3 "Combined calibration response nominal parameters"](#) on page 50 by $2\pi f$, where f is the frequency of the sinusoid.

10.2 Self-Noise

[Figure 10-2](#) plots typical self-noise for Trillium 240 seismometers. Three curves are included for reference: Peterson's new low-noise model (NLNM) and new high-noise model (NHNM), and McNamara and Buland's probability density function (PDF) mode low noise model (MLNM).¹ The noise floor shown is the typical level of instrument self-noise assuming proper installation. To achieve best performance for any seismometer, meticulous attention to detail must be paid to choice of site, vault design, and seismometer installation. See [Chapter 2 "Selecting and Preparing a Site"](#) and [Chapter 3 "Installing a Trillium 240."](#)

Figure 10-2 Trillium 240 self-noise

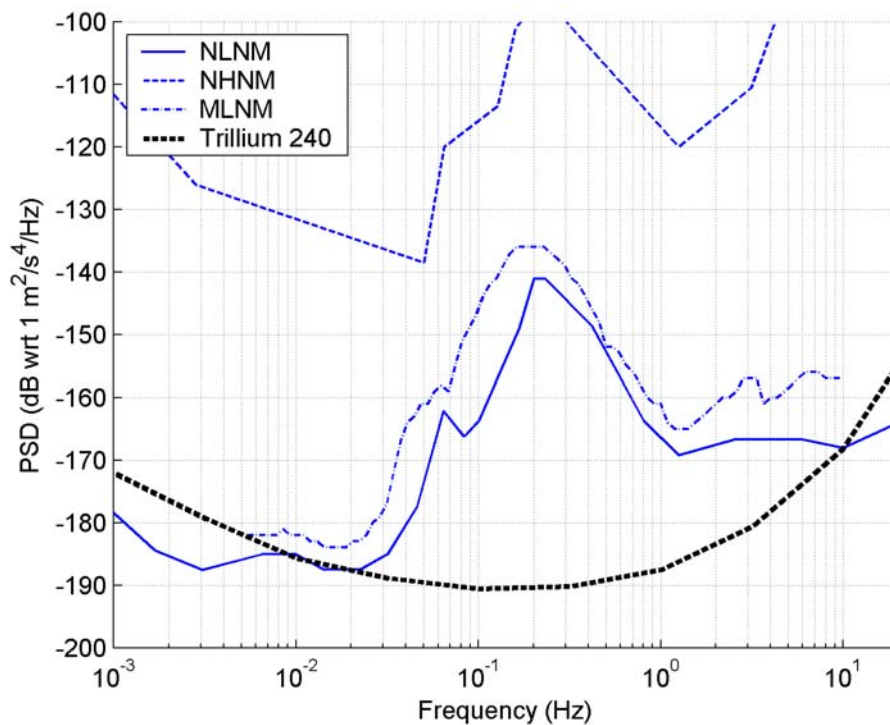

1. See also:

Jon Peterson, *Observations and Modeling of Seismic Background Noise, Open-File Report 93-922* (Albuquerque, New Mexico: U.S. Department of Interior Geological Survey, 1993).

Daniel E. McNamara and Raymond P. Buland, "Ambient Noise Levels in the Continental United States," *Bulletin of the Seismological Society of America* 94, 4 (August 2004): 1517–1527.

John F. Clinton and Thomas H. Heaton, "Potential Advantages of a Strong-motion Velocity Meter over a Strong-motion Accelerometer," *Seismological Research Letters* 73, 3 (May/June 2002): 332–342.

To determine the dynamic range at frequencies of interest for your application, compare the noise floor to the Trillium 240 clip level using Figure 10-3. For the purpose of comparing noise floors to clip levels, Figure 10-3 converts power spectral densities using octave bandwidths and an RMS-to-peak conversion factor of 1.253.

Figure 10-3 Trillium 240 performance

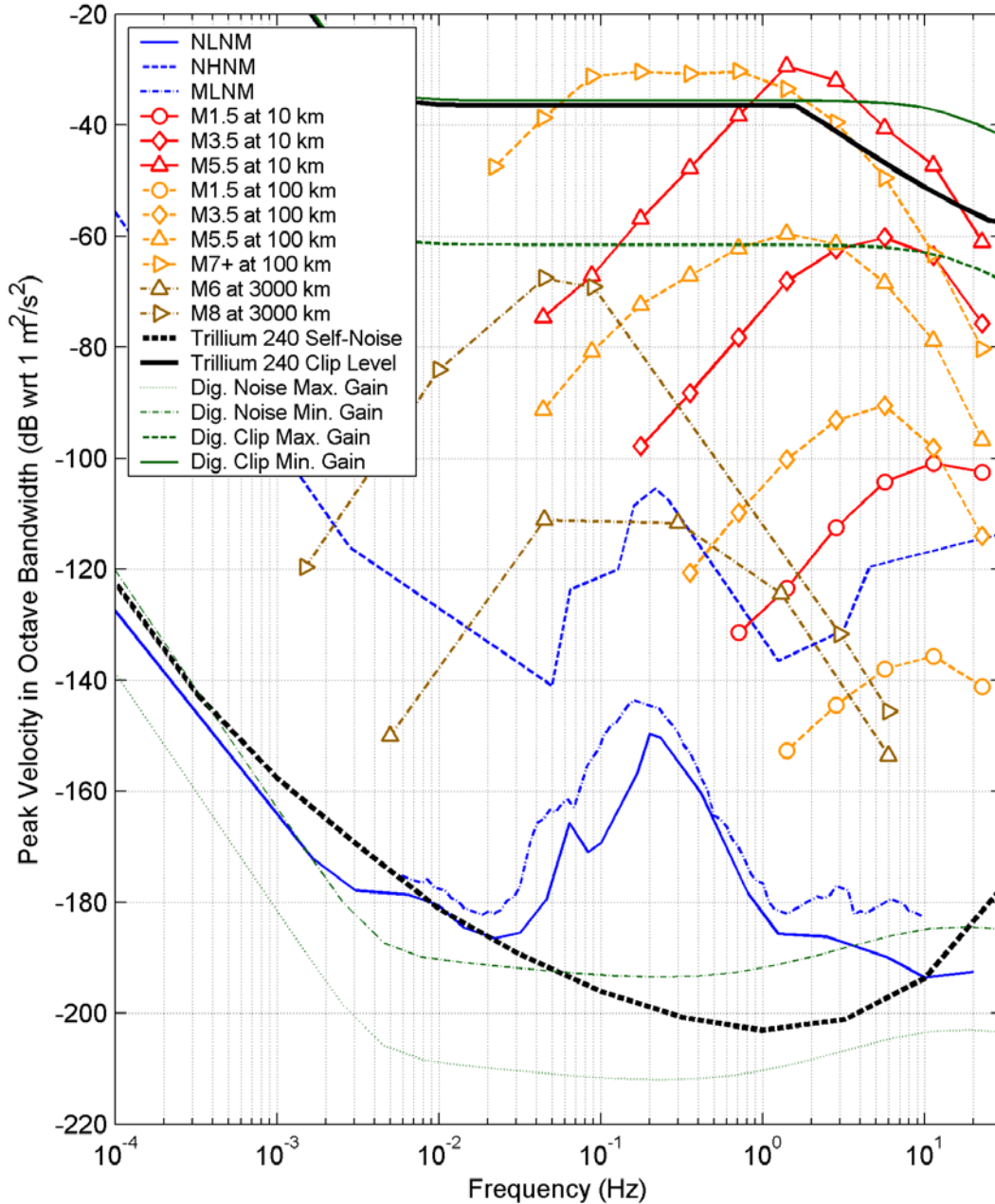

Chapter 11

Connector and Cables

- ◆ [Connector Pinout](#)
- ◆ [Seismometer Cable Pinout](#)
- ◆ [Cable Design Guidelines](#)

11.1 Connector Pinout

The Trillium 240 connector is a 19-pin male military circular type hermetic connector. [Table 11-1](#) provides the connector pinout.

Table 11-1 Connector pinout

Pin	Name	Function	Type
L	Z+/W+	vertical (W axis) output	40 Vpp differential
M	Z-/W-		
N	Y+/V+	north-south (V axis) output	
A	Y-/V-		
P	X+/U+	east-west (U axis) output	
B	X-/U-		
T	CAL_SIG	calibration signal input	9.2 k Ω input impedance 0.010467 (m/s ²)/V nominal
K	U_CALEN	calibration enable inputs	active-high 5 V to 15 V (low = open or 0 V)
J	V_CALEN		
U	W_CALEN		
E	U_MP	mass position outputs	± 4.0 V single-ended
F	V_MP		
S	W_MP		
V	AGND	analog ground	N/A
H	+PWR	power input	9 V to 36 V DC isolated
G	-PWR	power return	
D	UVW/TX	<ul style="list-style-type: none"> ◆ input: enable UVW instead of XYZ outputs ◆ output: serial RS-232 transmit 	<ul style="list-style-type: none"> ◆ as UVW input: active-high 5 V to 15 V; (low = open or 0 V) ◆ as TX output: ± 5 V
C	MC/RX	<ul style="list-style-type: none"> ◆ input: initiate mass centring ◆ input: serial RS-232 receive 	<ul style="list-style-type: none"> ◆ as MC input: active-high 5 V to 15 V; (low = open or 0 V) ◆ as RX input: +5 V/0 V to ± 15 V
R	DGND	digital ground	N/A
shell	CHASSIS	for shielding and safety	N/A

11.2 Seismometer Cable Pinout

A seismometer cable, Nanometrics part number 16169-nM or 16170-nM (where n is the length of the cable in metres), may be included with your Trillium 240. [Table 11-2](#) provides the pinout for part number 16169-nM and [Table 11-3 "Seismometer cable wiring for cable 16170-nM \(open-ended cable\)"](#) on page 56 provides the pinout for part number 16170-nM. A label with the part number is located on the cable. Use the appropriate pinout table for the appropriate cable as a reference when wiring the seismometer cable to a digitizer connector.

Table 11-2 Seismometer cable wiring for cable 16169-nM (for Nanometrics digitizers)



Nanometrics Digitizer			Seismometer			Wire Colour	Run
Connector	Pin	Name	Connector	Pin	Name		
P1	U	CH1+	P2	L	Z+/W+	Brown	1
P1	C	CH1-	P2	M	Z-/W-	Black	1
P1	B	CH1 GND				DRAIN	1
P1	A	CH2+	P2	N	Y+/V+	Orange	2
P1	S	CH2-	P2	A	Y-/V-	Black	2
P1	T	CH2 GND				DRAIN	2
P1	a	CH3+	P2	P	X+/U+	Yellow	3
P1	P	CH3-	P2	B	X-/U-	Black	3
P1	R	CH3 GND				DRAIN	3
P1	N	CAL1+	P2	T	CAL_SIG	White	
P1	Z	CAL1-/CTRL4	P2	U	W_CALEN	Black	
P1	c	CAL2-/CTRL5	P2	J	V_CALEN	Brown	
P1	Y	CAL3-/CTRL6	P2	K	U_CALEN	Red	
P1	K	EXT_SOH1	P2	S	W_MP	Orange	
P1	X	EXT_SOH2	P2	F	V_MP	Yellow	
P1	J	EXT_SOH3	P2	E	U_MP	Green	
P1	B	CH1 GND	P2	V	AGND	Pink	
P1	F	SEN +12V	P2	H	+BAT	Red	4
P1	D	SEN RTN	P2	G	-BAT	Black	4
P1	b	CHGND				DRAIN	4
P1	H	CTRL1	P2	D	UVW	Blue	
P1	W	CTRL2	P2	C	ACC	Purple	
P1	V	DGND	P2	R	DGND	Grey	
P1	M	CAL2+	P1	N	CAL1+	Yellow	
P1	L	CAL3+	P1	M	CAL2+	Yellow	
P1		SHELL	P2		SHELL/BAND	Overall/Shield	
P1	G	CTRL3					
P1	E	SEN -12V					

Table 11-3 Seismometer cable wiring for cable 16170-nM (open-ended cable)

Seismometer			Digitizer			Wire Colour	Run
Connector	Pin	Name	Connector	Pin	Name		
P1	L	Z+/W+	P2		CH1+	Brown	1
P1	M	Z-/W-	P2		CH1-	Black	1
P1					CH1 GND	DRAIN	1
P1	N	Y+/V+	P2		CH2+	Orange	2
P1	A	Y-/V-	P2		CH2-	Black	2
P1					CH2 GND	DRAIN	2
P1	P	X+/V+	P2		CH3+	Yellow	3
P1	B	X-/U-	P2		CH3-	Black	3
P1					CH3 GND	DRAIN	3
P1	T	CAL_SIG	P2		CAL1+	White	
P1	U	W_CALEN	P2		CAL1-	Black	
P1	J	V_CALEN	P2		CAL2-	Brown	
P1	K	U_CALEN	P2		CAL3-	Red	
P1	S	W_MP	P2		EXT_SOH1	Orange	
P1	F	V_MP	P2		EXT_SOH2	Yellow	
P1	E	U_MP	P2		EXT_SOH3	Green	
P1	V	AGND	P2		CH1 GND	Pink	
P1	H	+BAT	P2		SEN +12V	Red	4
P1	G	-BAT	P2		SEN RTN	Black	4
P1			P2		CHGND	DRAIN	4
P1	D	UVW	P2		CTRL1	Blue	
P1	C	ACC	P2		CTRL2	Purple	
P1	R	DGND	P2		DGND	Grey	
P1		Shell/Band	P2		Shell	Overall/Shield	

11.3 Cable Design Guidelines

If you are designing your own cable, use the following cable design guidelines:

- ♦ Include effective EMI shielding in the cable design.
 -  Double-shielded twisted-pair cable is a good choice for EMI shielding as the twisted pairs provide magnetic shielding, an inner shield grounded at the digitizer provides good electric field shielding, and a continuous outer shield provides good high RF shielding.
- ♦ Use the DGND for the return currents of the control signals (U_CALEN, V_CALEN, W_CALEN, UVW/TX and MC/RX).
- ♦ Use the AGND for the return currents of the analog signals (CAL_SIG, U_MP, V_MP, and W_MP).
 -  AGND is connected to CHGND inside the seismometer. If AGND is connected through the cable, the case of the Trillium 240 should be isolated from earth ground to prevent a ground loop.
- ♦ Ensure that the cable capacitance does not exceed 10 nF. For Nanometrics cables, this corresponds to 25 m.
- ♦ Ensure the cable length is sufficient to allow for strain relief.
- ♦ Ensure that the peak current requirement of the Trillium 240 does not result in a voltage drop along the cable which takes the power supply voltage below the minimum required at the Trillium 240. See [Table 9-4 "Power specifications"](#) on page 44.
- ♦ Ensure the cable is watertight.
- ♦ Check the cable electrically after assembly. In particular, ensure that the individual and overall shields are not shorted together unless so specified.
- ♦ Make sure cables are labelled with correct drawing numbers and revisions.
- ♦ Make sure the digitizer is configured so that the default states of the control lines put the Trillium 240 in the desired state.

Chapter 12

Alignment Features and Dimensions

- Top View of Alignment Features
- Bottom View of Alignment Features and Dimensions
- Side View of Dimensions

12.1 Top View of Alignment Features

Figure 12-1 is an illustration that shows the relative orientation of the east-west and north-south alignment features on a Trillium 240 seismometer.

Figure 12-1 Top view of alignment features

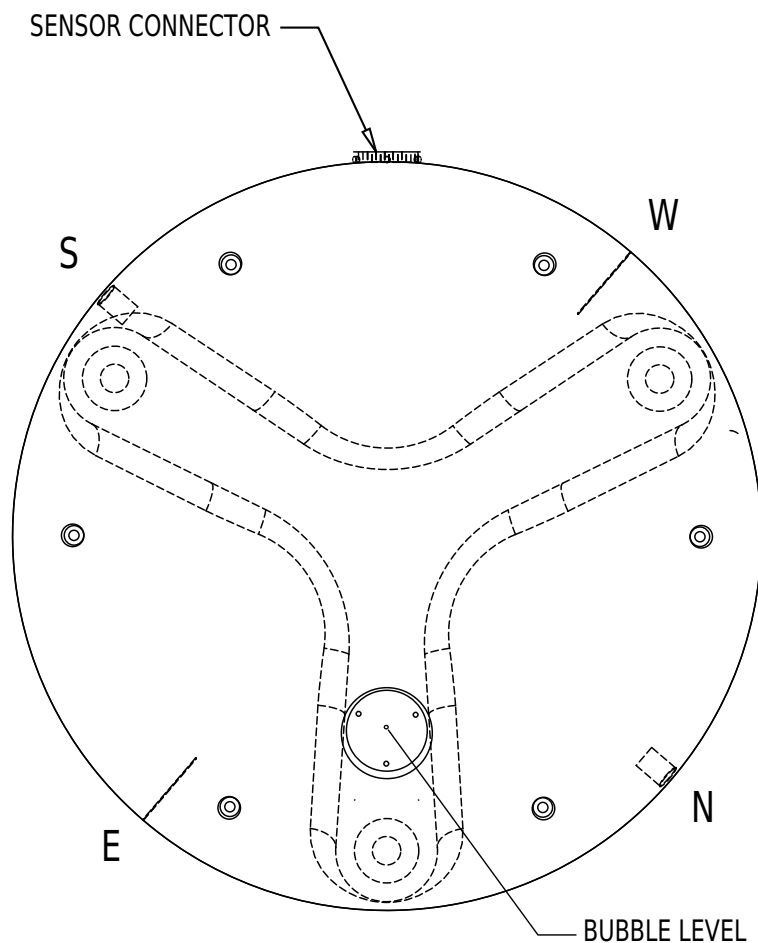

12.2 Bottom View of Alignment Features and Dimensions

Figure 12-2 is an illustration that shows the relative orientation of the east-west and north-south alignment features and dimensions for a Trillium 240 seismometer.



All dimensions are in millimetres unless otherwise stated.

Figure 12-2 Bottom view of alignment features and dimensions

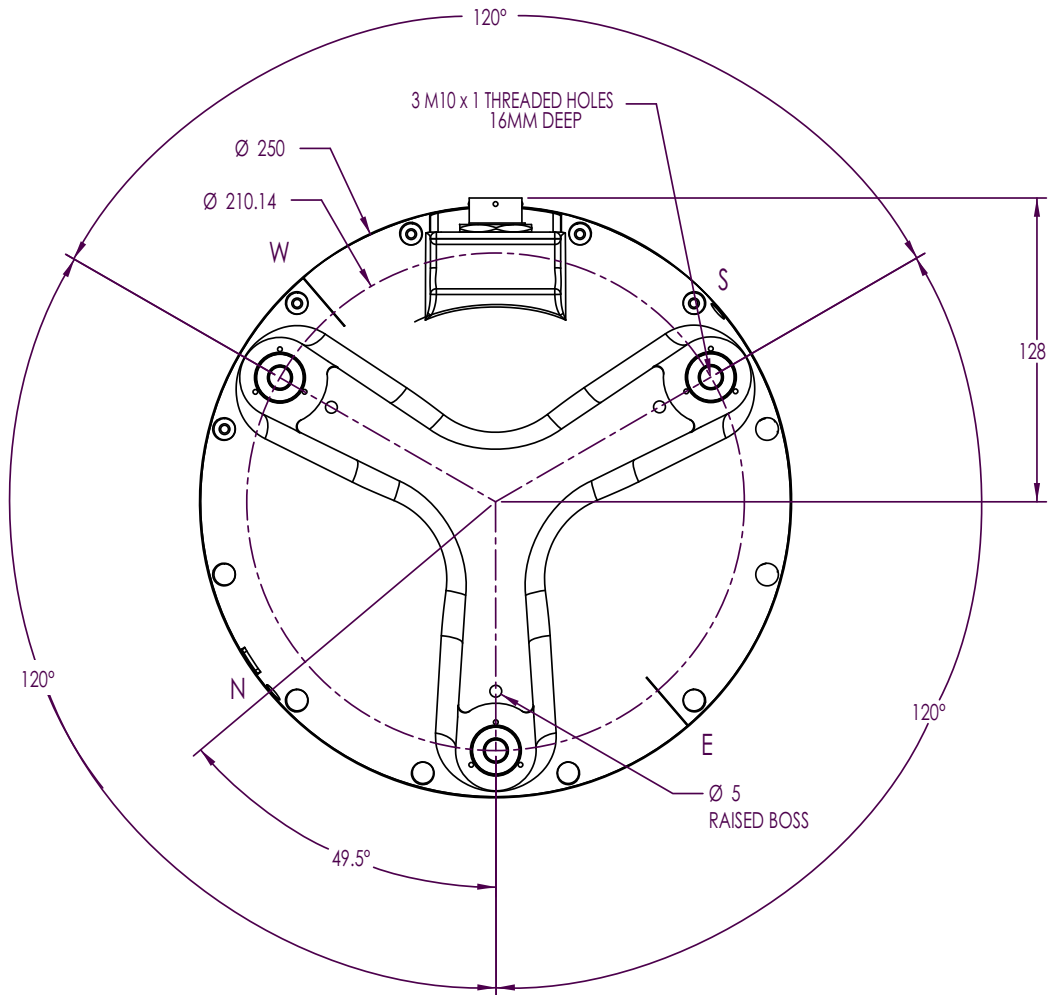

12.3 Side View of Dimensions

Figure 12-3 is an illustration that shows the alignment features and dimensions of a Trillium 240 seismometer from the side.



All dimensions are in millimetres.

Figure 12-3 Side view of alignment features

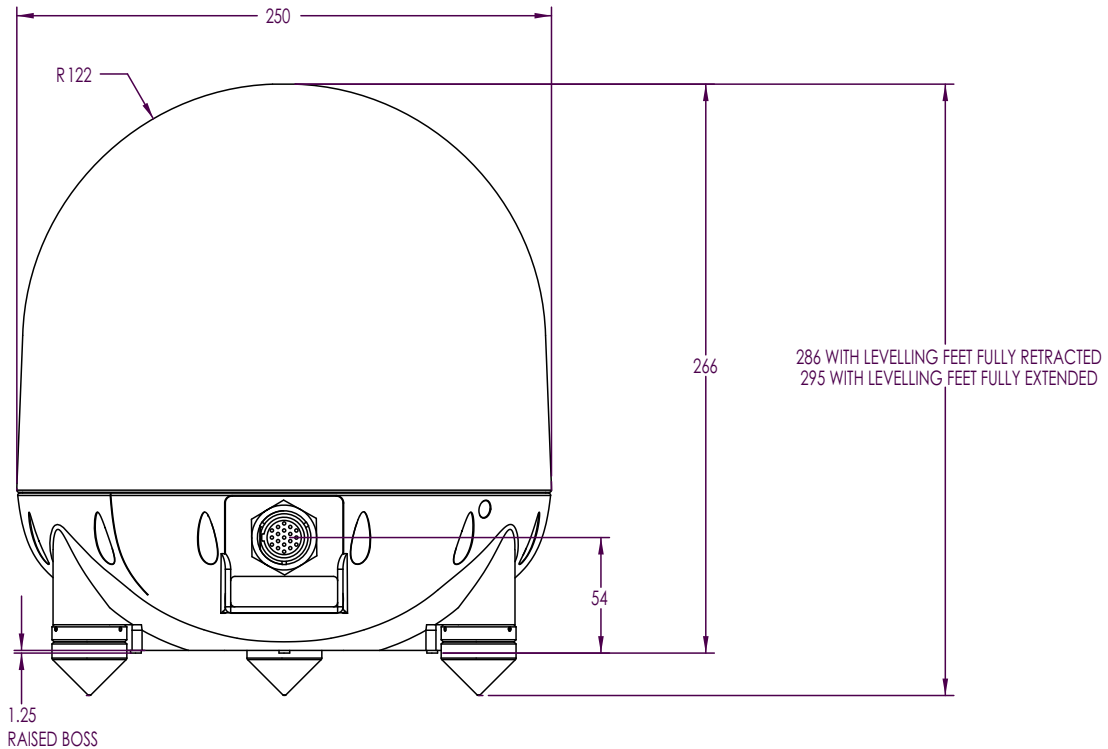

Appendix A

Glossary

- ♦ [Glossary of Abbreviations and Terms](#)
- ♦ [List of Unit Abbreviations and Symbols](#)

A.1 Glossary of Abbreviations and Terms

A

ADC

Analog to Digital Converter

AGND

Analog Ground

AWG

American Wire Gauge

C

CHGND

Chassis Ground

D

DGND

Digital Ground

E

EMI

Electromagnetic Interference

F

FBE

Feedback Electronics

G

GPS

Global Positioning System

M

MLNM

Mode Low Noise Model

N

NEMA

National Electrical Manufacturers Association

NHNM

New High-Noise Model

NLNM

New Low-Noise Model

NMSOP

New Manual of Seismological Observatory Practice

P

PDF

Probability Density Function

PWR

Power

R

RF

Radio Frequency

RMA

Return Merchandise Authorization

RMS

Root Mean Squared

T

TCP/IP

Transmission Control Protocol/Internet Protocol

A.2 List of Unit Abbreviations and Symbols

Table A-1 provides a list of unit abbreviations and symbols commonly used in Nanometrics documentation.

Table A-1 Unit Abbreviations and Symbols

Abbreviation or Symbol	Definition	Abbreviation or Symbol	Definition
°	degree	lb	pound
μ	micro	m	metre
Ω	ohm	m/s	metre per second
A	ampere	m/s ²	metre per second, squared
AC	alternating current	mA	milliampere
b	bit	MB	megabyte
B	byte	MΩ	megaohm
bps	bits per second	mi.	mile
C	Celsius	mL	millilitre
cm	centimetre	mm	millimetre
dB	decibel	ms	millisecond
DC	direct current	MTU	maximum transmission unit
F	farad	mV	millivolt
ft.	foot	mW	milliwatt
g	gram	N	Newton
<i>g</i>	gravity	nF	nanofarad
GB	gigabyte	ns	nanosecond
Hz	hertz	rad	radian
in.	inch	rad/s	radian per second
KB	kilobyte	s	second
kg	kilogram	sps	samples per second
kHz	kilohertz	U	rack unit
kΩ	kiloohm	V	volt
kW	kilowatt	V _{pp}	Volts peak-to-peak
L	litre	W	watt

About Nanometrics

Nanometrics is a world leader in the development of precision instrumentation, network technology, and software applications for seismological and environmental studies. Using Nanometrics technology, our customers establish and grow research networks that are often located in extreme environments such as the frozen Arctic and Antarctic, the arid deserts of the Middle East, the jungles of South America, and the depths of the world's oceans. Many of these are mission-critical national and regional networks that demand the highest possible data quality and availability.

Nanometrics provides end-to-end solutions that include a growing portfolio of broadband and strong motion seismometers, dataloggers and digitizers, satellite ground station systems for remote site data collection, and software applications for data and network analysis and management. To support this portfolio, Nanometrics also provides global systems engineering services for design, installation, and support of complete networks.

Our head office, research and development centre, and production facility are located in the Kanata North Business Park of Ottawa, the high-technology heart of Canada's capital region.

Contacting Nanometrics

Nanometrics Inc.
250 Herzberg Road
Kanata, Ontario, Canada K2K 2A1
Phone: +1 613-592-6776
Fax: +1 613-592-5929
Email: info@nanometrics.ca
Web: www.nanometrics.ca

Contacting Technical Support

If you need technical support please submit a request on the Nanometrics technical support site or by email or fax. Include a full explanation of the problem and related information such as log files.

Support site: <http://support.nanometrics.ca>
Email: techsupport@nanometrics.ca