



Operation Manual for Mag-03 Three-Axis Magnetic Field Sensors



(89/336/EEC)
EMC DIRECTIVE

Specifications may be subject to slight alteration without prior notice. This system is not qualified for use in explosive atmospheres or life support systems. Consult Bartington Instruments for advice.

The copyright of this document is the property of Bartington Instruments Ltd. The document is supplied on the condition that it is to be treated commercially confidential and it may not therefore be disclosed to any third party without written authorisation of the Managing Directors of Bartington instruments

www.bartington.com

Bartington Instruments Limited
5 & 10 Thorney Leys Business Park
Witney, Oxford, OX28 4GE, England.

T: +44 (0)1993 706565
F: +44 (0)1993 774813
E: sales@bartington.com

Bartington[®]
Instruments

LIST OF CONTENTS

- 1 INTRODUCTION
- 2 GENERAL DESCRIPTION
- 3 ENCLOSURES
 - 3.1 *Mag-03MC*
 - 3.2 *Mag-03MCES*
 - 3.3 *Mag-03MCFL*
 - 3.4 *Mag-03MCT*
 - 3.5 *Mag-03MS*
 - 3.6 *Mag-03MSES*
 - 3.7 *Mag-03MSS*
 - 3.8 *Mag-03IE*
 - 3.9 *Mag-03IEv1 & v2*
 - 3.10 *Mag-03IEHV*
 - 3.11 *Mag-03MCTP*
 - 3.12 *Mag-03MCUP*
- 4 ACCESSORIES
 - 4.1 *Mag-03PSU* POWER SUPPLY UNIT
 - 4.2 *Spectramag-6* DATA ACQUISITION SYSTEM
 - 4.3 *Mag-03SCU* SIGNAL CONDITIONING UNIT
 - 4.4 *Mag-03MC-CU* CALIBRATION UNIT
 - 4.5 CABLES
 - 4.6 *Mag-03MC-BR* MOUNTING BRACKET
 - 4.7 MATING CONNECTORS
- 5 MOUNTING
 - 5.1 *Mag-03MC/Mag-03IE*
 - 5.2 *Mag-03MS*
 - 5.3 *Mag-03MSS*
 - 5.4 OTHER TYPES
- 6 OPERATION
 - 6.1 CONNECTOR PIN ALLOCATION
 - 6.2 INTERFACE
 - 6.3 POWER SUPPLIES
 - 6.4 SIGNAL/POWER GROUND
 - 6.5 CABLING
 - 6.6 CONNECTING POWER
 - 6.7 RESPONSE
 - 6.8 ELECTROMAGNETIC COMPATIBILITY
- 7 PERFORMANCE
 - 7.1 FREQUENCY RESPONSE
 - 7.2 NOISE
 - 7.3 OVER RANGE
- 8 SIGNAL PROCESSING

- 9 CARE AND MAINTENANCE
- 10 MAGNETIC UNITS AND MEASUREMENTS
 - 10.1 CONVENTIONS
 - 10.2 MEASUREMENT UNITS
 - 10.3 CONVERSION TABLE
 - 10.4 VECTOR MEASUREMENTS
- 11 TECHNICAL SPECIFICATIONS
 - 11.1 SENSORS
 - 11.2 CABLES
- 12 FIGURES

LIST OF FIGURES

- FIGURE 1 *Mag-03MC* SENSOR OUTLINE WITH MATING CONNECTOR
- FIGURE 2 *Mag-03MCES* & *MCT* SENSOR OUTLINE WITH MATING CONNECTOR
- FIGURE 3 *Mag-03MCFL* SENSOR OUTLINE
- FIGURE 4 *Mag-03MS* SENSOR OUTLINE WITH MATING CONNECTOR
- FIGURE 5 *Mag-03MSES* SENSOR OUTLINE WITH MATING CONNECTOR
- FIGURE 6 *Mag-03MSS* SENSOR OUTLINE WITH MATING CONNECTOR
- FIGURE 7 *Mag-03IE* SENSOR OUTLINE WITH MATING CONNECTOR
- FIGURE 8 *Mag-03IEv1* & *v2* SENSOR OUTLINE
- FIGURE 9 *Mag-03IEHV* SENSOR OUTLINE
- FIGURE 10 *Mag-03MCTP* SENSOR OUTLINE WITH MATING CONNECTOR
- FIGURE 11 *Mag-03MCUP* SENSOR OUTLINE
- FIGURE 12 *Mag-03MC* CABLE
- FIGURE 13 *Mag-03MCES* CABLE
- FIGURE 14 *Mag-03MS* CABLE
- FIGURE 15 *Mag-03MSES* CABLE
- FIGURE 16 *Mag-03MSS* CABLE
- FIGURE 17 *Mag-03MC-BR* MOUNTING BRACKET
- FIGURE 18 *Mag-03* INTERFACE SCHEMATIC
- FIGURE 19 *Mag-03* TYPICAL AMPLITUDE & PHASE RESPONSE
- FIGURE 20 *Mag-03* NOISE PLOT STANDARD VERSION
- FIGURE 21 *Mag-03* NOISE PLOT LOW NOISE VERSION

1 INTRODUCTION

This manual describes the operation of the *Mag-03* range of three axis magnetic field sensors. These compact high performance sensors with integral electronics provide measurements of static and alternating magnetic fields in three axes. The sensors, alternatively described as magnetometers, convert magnetic flux density, measured in three axes, into a bipolar analog voltage. Analog output voltages V_x , V_y and V_z are in linear proportion to the flux density.

In designing the *Mag-03* series, the policy has been to provide a high performance sensor having a flat amplitude response and a small, predictable phase lag over a wide bandwidth. In order to offer maximum flexibility and not degrade the performance, the sensor has no internal filters. The analog outputs may require external filters to optimise the performance depending on the application. The *Mag-03PSU* power supply contains simple filters which may be sufficient, but for more stringent requirements the *Mag-03SCU* signal conditioning unit may be appropriate.

The sensors are available in a variety of enclosures, as detailed below, with five measuring ranges. A low noise version can be supplied in all packages, except the MCT, with a measuring range of $\pm 70\mu\text{T}$ or $\pm 100\mu\text{T}$.

TYPE	ENCLOSURE	MEASURING RANGE (μT)					ORTHOGONALITY ERROR ($^\circ$)	
		70	100	250	500	1000	0.1	0.5
<i>Mag-03MC</i>	Cylindrical	*	*	*	*	*		*
<i>Mag-03MCES</i>	Cylindrical - environmentally sealed connector	*	*	*	*	*		*
<i>Mag-03MCFL</i>	Cylindrical with flying leads	*	*	*	*	*		*
<i>Mag-03MCT</i>	Cylindrical in a shielded Titanium enclosure	*	*	*	*	*		*
<i>Mag-03MS</i>	Square section	*	*	*	*	*	*	
<i>Mag-03MSES</i>	Square section - environmentally sealed connector	*	*	*	*	*	*	
<i>Mag-03MSS</i>	Square section submersible to 100 metres	*	*	*	*	*		*
<i>Mag-03IE</i> <i>Mag-03IEv1</i> <i>Mag-03IEv2</i> <i>Mag-03IEHV</i>	Cylindrical with independent sensor elements	*	*	*	*	*		
<i>Mag-03MCTP</i> (to special order)	Cylindrical - two part construction	*	*	*	*	*		*
<i>Mag-03MCUP</i> (to special order)	Unpackaged	*	*	*	*	*		*

TABLE 1. *Mag-03* SENSORS

Products are specified as *Mag-03* followed by the enclosure code (MC, MCES, MCFL, MS, MSES, MSS or IE), followed by L for the low noise version or B for the Basic version; if neither L nor B is specified, then this indicates the Standard version. Follow this with the measuring range in μT (70, 100, 250, 500 or 1000).

e.g. *Mag-03MSL70* is a square section low noise sensor with a range of $\pm 70\mu\text{T}$

Mag-03MC1000 is a cylindrical enclosure and a range of $\pm 1000\mu\text{T}$

Mag-03MSESB250 is a basic sensor, square section, environmentally-sealed connector and range of $\pm 250\mu\text{T}$

A re-calibration service is available which is traceable to international standards.

2 GENERAL DESCRIPTION

This section describes the features common to the *Mag-03* range of sensors. Where there are exceptions they are described under Section 3 detailing the different types of enclosures.

Three fluxgate sensing elements are mounted orthogonally at one end of an enclosure which also contains the electronic circuitry. The connector is mounted at the opposite end of the enclosure. The position and direction of each sensing element is shown on the outside of the sensor, together with the product code, measuring range and serial number.

Details of the enclosures, mounting, connector dimensions, connector pin allocation and the position of the sensing elements relative to the enclosure are given on the relevant figure showing the outline and connector detail. The sensor elements are precisely aligned along the centre lines of the package.

The sensors require a power supply of between $\pm 12V$ and $\pm 17V$ and provide three high precision analog outputs of 0 to $\pm 10V$ full scale, proportional to the magnetic field along each axis. For a unit with a full scale range of $\pm 100\mu T$ the output voltage for each axis is $0.1V/\mu T$ of the field in the direction of that axis. The relationship between the magnetic field and the analog output is extremely linear and the frequency response is maximally flat from d.c. to 1kHz with a bandwidth of 3kHz.

The low output impedance of the sensor ensures it can be operated over long cables and permits it to be interfaced to low impedance data acquisition systems. The zero field offset error, scale factor, orthogonality and frequency response are individually calibrated.

3 ENCLOSURES

3.1 *Mag-03MC* - Figure 1

The sensing elements and electronic circuitry are housed in a reinforced epoxy cylindrical enclosure with a circular connector. The sensor is suitable for use in shallow boreholes but is not sealed against the ingress of water. A mounting bracket is available as an option. The label area is recessed and should not be used for clamping.

3.2 *Mag-03MCES* - Figure 2

This enclosure is the same as the *Mag-03MC* but features a rugged, seven way sealed connector to provide an IP64 rated unit.

3.3 *Mag-03MCFL* - Figure 3

This enclosure is identical to the *Mag-03MC* except that no connector is used, a seven way connecting cable is moulded within the enclosure with a strain relief grommet. The standard length of flying lead is 500mm. Flying leads are susceptible to EM interference and should be screened wherever possible.

3.4 *Mag-03MCT* - Figure 2

This is the same as the *Mag-03MC* except that it is a shielded Titanium enclosure and features a rugged, seven way sealed connector to provide an IP64 rated unit.

3.5 *Mag-03MS* - Figure 4

This square section enclosure is manufactured from reinforced epoxy and the sensing elements are mounted with reference to the base which acts as a datum face.

The Z axis is aligned to this reference face to an accuracy of 0.1° . The orthogonality error between the magnetic axes is also 0.1° for this sensor compared to the standard 0.5° error for the other sensors in the range.

The connector is a nine pin D type plug and has pillars for securing the mating connector. The pillars are tapped with UNC 4-40 threads, standard for this type of connector, but the use of retaining screws on the mating connector should be avoided unless it can be ascertained that they contain no magnetic material, which would influence the field at the sensor elements. Retaining screws commonly contain spring washers or circlips which are manufactured from ferrous material which render them unsuitable.

3.6 *Mag-03MSES* - Figure 5

This enclosure is the same as the *Mag-03MS* but features an environmentally sealed connector to provide an IP64 rated unit. The connector is a rugged, seven way sealed type. A sealing gasket may be required on the base of the sensor.

3.7 *Mag-03MSS* - Figure 6

This square section enclosure is designed for marine use and is IP68 rated and submersible to depths of 100 metres. The pressure housing is manufactured from polyacetal for minimum water absorption.

The connector is a seven way marine type and the mating connector is supplied moulded to a seven way polyurethane jacketed marine cable. The cable is supplied to customer requirement up to a length of 600 metres.

3.8 *Mag-03IE* - Figure 7

This sensor has a shortened cylindrical enclosure for the electronics and the three sensing elements are individually potted and connected to the electronics assembly with flying leads which have a standard length of 750mm. This allows the user to position the individual elements independently if required. The sensing elements can be arranged around a sensitive volume where space is restricted. The connector is the same as for the *Mag-03MC*.

3.9 *Mag-03IEv1* & *Mag-03IEv2* - Figure 8

These sensors are identical to the *Mag-03IE* except that the *Mag-03IEv1* has a 5m cable with a 9 pin 'D' type connector and the *Mag-03IEv2* has a 5m cable with a 25 pin 'D' type connector. The bandwidth can be increased to 5kHz, on request.

3.10 *Mag-03IEHV* - Figure 9

This sensor enables measurements to be made in high vacuum. The sensor is identical to the *Mag-03IE* except that the independent elements are enclosed in glass tubes with an epoxy filling. A re-solderable terminal block in the sensor element cables allows connection through a vacuum chamber bulkhead.

3.11 *Mag-03MCTP* - Figure 10

This enclosure provides a two part construction. The sensing elements and electronics are contained in two separate cylindrical enclosures connected by a 1000mm ribbon cable and a simple eight pin dual in-line socket. The sensing elements are completely encapsulated in epoxy resin within their enclosure.

The external connector is the same as for the *Mag-03MC*.

3.12 *Mag-03MCUP* - Figure 11

This arrangement is an “unpacked” version. The sensing elements are encapsulated in a cylindrical enclosure but the electronics printed circuit board is simply coated in silicone rubber and not protected by an enclosure. Two four-way ribbon cables, with a standard length of 140mm but available in lengths to 500mm, connect the sensing elements to the electronics board. Connection to the complete unit is by a flying lead. Flying leads are susceptible to EM interference and should be screened wherever possible.

4 ACCESSORIES

The optional accessories for the *Mag-03* range of sensors are as follows:

4.1 *Mag-03PSU* POWER SUPPLY UNIT

This unit supplies power to any of the *Mag-03* sensors from an internal rechargeable battery. It produces a fully isolated $\pm 12V$ supply which provides 10 hours of continuous operation. The battery can be recharged in a few hours using the mains adaptor provided. A high pass and a low pass filter are provided in each signal path to provide a.c. or d.c. response and to remove high frequency noise.

Full specifications of the *Mag-03PSU* are provided in the *Mag-03* brochure DS0013 and the operation manual OM0065.

4.2 *Spectramag-6* DATA ACQUISITION SYSTEM

Spectramag-6 six-channel, 24-bit data acquisition and spectrum analysis system for use with the *Mag-03* range of 3-axis magnetometers and any accelerometers with an ICP interface. All six-channels are sampled simultaneously making the *Spectramag-6* ideal for recording and analysing the magnetic field and vibration data in three axes.

The unit is supplied with Windows compatible software with real-time data display and full export capability of data and graphics. Full details of *Spectramag-6* are provided in the brochure DS0013 and in the operation manual OM2021.

4.3 *Mag-03SCU* SIGNAL CONDITIONING UNIT

This mains powered signal conditioning unit supplies power to a three axis sensor and allows a filter to be configured with separate controls for the low pass and high pass sections. The filter is applied to each output channel of the sensor. Control of gain and offset is provided for each channel independently. Full details are provided in the brochure DS0012 and the operation manual OM0941.

4.4 *Mag-03* CALIBRATION UNITS

The *Mag-03MS-CU* is a battery powered unit which produces a sinusoidal alternating magnetic field of defined frequency and magnitude. The unit provides a reference magnetic field for checking the calibration of the *Mag-03MS* sensors which have a square enclosure. For calibration checking *Mag-03MC* and *Mag-03IE* sensors, adaptors are available for use with the *Mag-03MS-CU*.

A separate calibration unit, *Mag-03MSS-CU* is available for the *Mag-03MSS* submersible sensors.

A temperature stabilised constant current is passed through a single Helmholtz coil with guides to align each of the sensor axes in turn. Full details are provided in the *Mag-03* brochure DS0013.

4.5 CABLES

Cables are available for connection of the three axis range of sensors to the *Mag-03PSU*, *Spectramag-6* or *Mag-03SCU*. Specifications for each of the cables are given in Section 12. The cables are shown, with their connector pin allocations, in the following figures:

Mag-03MC cable - FIGURE 12 (also used for *Mag-03IE*)

Mag-03MCES cable - FIGURE 13

Mag-03MS cable - FIGURE 14

Mag-03MSES cable - FIGURE 15

Mag-03MSS cable - FIGURE 16

4.6 *Mag-03MC-BR* MOUNTING BRACKET (Figure 17)

This mounting bracket for the *Mag-03MC* cylindrical sensor clamps around the sensor body and provides mounting holes. The bracket is manufactured from reinforced epoxy resin and is supplied complete with nylon mounting screws.

4.7 MATING CONNECTORS

All sensors, except for the *Mag-03MSS*, are supplied with a non-magnetic mating connector if no cable for connection to a power supply or data acquisition module is purchased.

The *Mag-03MSS* mating connector must be purchased separately.

5 MOUNTING

The method of mounting will depend on the application and the enclosure. For details of the mounting arrangements refer to the relevant outline drawing. The use of magnetic materials in the mounting arrangement must be avoided. All mounting components should be checked before installation by introducing the component within the immediate vicinity of the sensing elements of a working magnetometer and observing any variation in the background field.

The analog output is positive for conventional flux direction South to North in the direction of the arrow shown on the label for each axis. i.e. the maximum positive output will be obtained from any axis when the arrow points towards magnetic north along the total field vector.

5.1 *Mag-03MC, Mag-03MCES, Mag-03MCT and Mag-03MCFL*

These sensors may be supported in the *Mag-03MC-BR* mounting bracket described in section 4.6. The label area of the sensor is recessed and should not be used for clamping.

5.2 *Mag-03MS and Mag-03MSES*

These sensors have threaded holes tapped in the base which is also the datum face. The sensors can be mounted on any flat, non-magnetic surface using the two brass screws supplied. A thin gasket or a suitable sealant should be used to seal the base of the units against water penetration. **The absolute maximum screw penetration depth within the body is 16 mm and this must not be exceeded.**

5.3 *Mag-03MSS*

The *Mag-03MSS* has a square section pressure housing with three mounting holes, 4 mm in diameter, drilled through the body and counterbored for cheese-headed screws. Screws are not provided due to the variable nature of the environmental service conditions which may be encountered.

5.4 OTHER TYPES

The mounting arrangements for other types will depend on the application. The *Mag-03IE* (all versions) electronics enclosure can be supported in the mounting bracket.

6 OPERATION

6.1 CONNECTOR PIN ALLOCATION (Figures 1 to 12)

The connector pin or cable colour allocation for the connection to each package type is shown on the appropriate outline drawing.

6.2 INTERFACE

A simplified interface schematic for the *Mag-03* series is shown in Figure 18. The sensor contains capacitors between the supplies and the signal/power ground line and all lines have internal fuses to limit the damage if the supplies are reversed or a voltage is applied above the rated level. These fuses are not replaceable by the user and no access is given to them. **NO PROTECTION IS PROVIDED AGAINST REVERSED POLARITY SUPPLIES OR SHORT CIRCUITS BETWEEN THE ANALOG OUTPUTS AND THE SUPPLIES OTHER THAN THESE FUSES.**

The analog outputs for the X, Y and Z axes are buffered to give a low output impedance, enabling the unit to be operated over long cables and interfaced to low impedance data acquisition systems.

6.3 POWER SUPPLIES

The *Mag-03PSU*, *Mag-03SCU* and *Spectramag-6* are the ideal power supply units. Alternatively users may wish to provide their own supply. This would normally provide $\pm 12\text{V}$ and, for the lowest noise applications, ripple in the output should be in the mV region. The nominal current requirements are $+35\text{mA}$ and -6mA for the standard and basic versions and $+26\text{mA}$ and -6mA for the low noise versions with an additional current in proportion to the measured field. The additional current is 1.4mA per $100\mu\text{T}$ per axis and will be drawn from the positive or negative supply depending on the direction of the field.

The maximum output voltage swing from the sensor will always be less than the supply voltage. In the temperature range -40°C to $+70^\circ\text{C}$, and with an external load of $10\text{k}\Omega$, the maximum output voltage will be less than the supply voltage by the value given in the Table 2 below. All parameters other than the output voltage range remain unaffected for supply voltage changes in the range from ± 8 to $\pm 15\text{V}$.

Nominal range (uT)	70	100	250	500	1000
$V_{\text{supply}} - V_{\text{output}}$ (V)	0.2	0.2	0.3	0.5	0.7

TABLE 2. OUTPUT VOLTAGE SWING

The current drain is independent of the power supply voltage and the unit will operate with input voltages down to $\pm 8\text{V}$. As the output voltage swing is limited to slightly less than the supply voltage, for a supply of $\pm 8\text{V}$ the output will operate normally with any output between $+7.3\text{V}$ and -7.3V representing a field of 0.73 of the full scale value in each direction. The scaling factor and linearity will remain at the normal value up to this saturation point. The output will remain at the saturation level if the field is increased beyond this point. Asymmetric supplies may be used provided that the minimum and maximum voltages are not exceeded for either polarity.

6.4 SIGNAL/POWER GROUND

The two *signal/power ground* conductors are connected to a common point within the sensor and the power supply common (power 0 V) should be connected to only one of them. The other *signal/power ground* conductor should be used as the signal output common (signal 0 V). Each signal is then measured between the signal output conductor and the signal output common. In this way the signal output common carries no power supply currents.

The minimum current in the power ground conductor is approximately 19mA and, on long cables, this will give rise to an appreciable potential difference between the power supply end and the sensor end of the power ground conductor. The use of separate power and signal ground conductors will ensure that this voltage is not included in the voltage measured between the signal output and the signal common.

In order to ensure that the power supply return current does not affect the analog measurements in any way, the following precautions should be observed:

- a. A signal common line, separate from the power return line, must be connected between the *Mag-03* magnetic field sensor and any measurement or data acquisition system.
- b. If the signal ground line is to constitute a system ground point then a fully floating power supply must be employed, e.g. a pair of batteries or a fully isolated power supply. A number of commercially available dc to dc converters fulfil the voltage isolation requirement adequately. For this arrangement only single ended analog inputs to the data acquisition system are required for the three axes.

- c. If the power supply is to constitute a system ground point then the data acquisition analog inputs must be of the differential type. Each differential input can then be connected between the remote end of the signal common line and the individual analog outputs.
- d. The above considerations also apply if more than one *Mag-03* sensor is used.
- e. Any data acquisition system analog inputs should ideally have a very high input impedance but satisfactory performance can be obtained with impedance's down to 10k Ω . Impedance's below this should be avoided, particularly where very long cables are used.
- f. To obtain optimum performance, additional care should be exercised to avoid ground currents in the signal leads when using the low noise unit.

When using the *Mag-03PSU* power supply, *Spectramag-6* data acquisition system or *Mag-03SCU* signal conditioning unit described in Section 4 the above requirements will be met without further consideration by the user.

6.5 CABLING

It is recommended that the connecting cable to the sensor is a eight-core screened cable. Two cores will be used for positive and negative power supply lines, three cores for output signals, one core for signal common and one for power supply ground. The screen should be connected to supply ground at the supply end only. The capacitance between cores should be less than 200pF per metre. A cable with individually shielded cores should be considered for long cable applications.

Note that on Flying Lead versions, leads are susceptible to EM interference and should be screened wherever possible.

The length of the cable is limited by the voltage drop in the power supply lines and the capacitance between the cores. For this reason it is recommended that the cable is limited to a maximum length of 600 metres.

Bartington Instruments can supply cables for connection of the sensor to the *Mag-03PSU*, *Spectramag-6* or *Mag-03SCU*. For details see Section 4.5. If no cable is ordered with the sensor a mating connector is provided.

6.6 CONNECTING POWER

CHECK THAT THE POLARITY OF THE SUPPLY IS CORRECT. Reversed connections will cause the internal fuses to blow (see Section 6.2). The power supply should be connected to the sensor before the supply is energised as this prevents high inrush currents which could cause damage. Apply the positive and negative supplies simultaneously and avoid leaving the sensor connected to one polarity only.

6.7 RESPONSE

The analog output V , for any channel, is proportional to the axial component b of the total field F . If θ is the angle subtended between the direction of F and sensing axis of the fluxgate element, then:

$$b = F \cos\theta \quad \text{and} \quad V \propto F \cos\theta$$

6.8 ELECTROMAGNETIC COMPATIBILITY

Except for the *Mag-03MCT*, the *Mag-03* range of sensors are not shielded for immunity from, or emission of, electromagnetic fields. Any shield placed around the sensor will limit the bandwidth of the sensor response. The emissions generated are at a low level with a primary frequency of 15kHz, being the frequency of the energising field of the sensor. The sensor is required to respond to magnetic fields within the specified frequency band.

The user should ensure that the sensor is not operated in areas where a high electromagnetic field exists, even if the frequency is above the bandwidth of the sensor, as false information may appear due to aliasing. This effect is seen in data acquisition systems when the frequency of sampling is lower than the frequency of the signal which is being sampled. It may produce apparent signals at lower frequencies than the noise, which may be within the frequency band of the sensor. Similarly, the user should not place the sensor near to any equipment which may be affected by the fields produced by the sensor excitation.

7 PERFORMANCE

7.1 FREQUENCY RESPONSE

The typical amplitude and phase response for the *Mag-03* range of sensors is shown in Figure 19.

The sensors provide a bandwidth of 3kHz with a maximally flat response to 1kHz.

7.2 NOISE

A typical noise plot for the standard version is shown in Figure 20 and for the low noise version in Figure 21.

The output signal for each axis will also contain signals at the power line frequency, other interference and the drive frequency of 15kHz. For many measurements these components will be outside the response of the readout or recording system. For applications where low field levels or measurements of the highest resolution are required it will be necessary to provide a filter to select only the frequency bands of interest.

7.3 OVER RANGE

Sensors are available with ranges from $\pm 70\mu\text{T}$, which corresponds to the maximum value of the earth's magnetic field, to $\pm 1000\mu\text{T}$. As the field in any axis approaches the full scale value, the output will rise in proportion until it reaches a value of approximately 0.8V less than the relevant supply line. The output will then saturate and remain at this level regardless of any further rise in the field. Very high fields in the hundreds of mT should be avoided as they may give rise to a few nT shift in offset measured at zero field.

8 SIGNAL PROCESSING

For different applications it may be necessary to process the signal from the sensor in different ways:

a. In order to increase the sensitivity of the recording system it may be necessary to back-off the earth's field and amplify only the changes in the field from the current value. This requires a high-pass filter, which could be a simple capacitively coupled arrangement or a multi-pole filter to provide a steep roll off characteristic. These features are all present in the *Mag-03SCU* signal conditioning unit.

b. To monitor small signals within the bandwidth of the sensor it may be necessary to remove the higher frequency noise which is outside the band of frequencies of interest. It may also be necessary when using sampling data acquisition systems to provide an anti-alias filter to prevent the appearance of apparent lower frequency components in the recorded signals due to the strobing effect of the sampling of the high frequency components. The filter should be a low-pass type with the top of the pass band as far below the sampling frequency as practical for the application.

c. In applications such as surveillance and magnetic signature monitoring it may be required to remove both the d.c. standing field and all a.c. noise and pick-up above a set frequency. The band of interest will be say, 0.01 to 10Hz and a band pass filter can be used to provide the required signal.

The output from all fluxgate sensors will contain noise from the driving electronics. For the *Mag-03* range this noise is at 15kHz which is well above the bandwidth of the sensors. Where low noise operation is required a filter should always be provided to reject the noise which lies outside the band of interest.

The *Mag-03PSU* power supply unit, which can be used with all sensors, contains three low pass filters with a -3dB point at 4.5kHz together with three high pass filters with a -3dB point at 0.1Hz.

The *Mag-03SCU* signal conditioning unit provides filters with independent control of the low and high pass filter sections together with offset and gain control for the output of each axis.

9 CARE AND MAINTENANCE

The *Mag-03* sensor contains no user-serviceable parts but, provided it is operated within the design limits, it will require no attention for many years. Surface or dirt contamination should be removed using a mild detergent solution only. If the connector pins become contaminated they should be lightly cleaned with a swab of isopropyl alcohol.

The unit must be returned to Bartington Instruments for repair or re-calibration. For the diagnosis of faults within the unit special equipment is required including a zero gauss shielded chamber, a calibrated test coil with traceable calibration, and a.c. and d.c. calibrated constant current sources. Much of this equipment is beyond the scope of normal service facilities. Any field tests are therefore limited to those which can detect if the magnetic field sensor and associated circuitry does not produce an analog voltage which is proportional to the magnetic flux.

If each sensor element in turn is rotated planar to the terrestrial magnetic field, a sinusoidal analog output should be produced at the relevant output. If this is not the case, or a gross asymmetry is seen in the output, then a fault clearly exists.

The frequency response of individual channels can be tested by comparing the analog outputs from each channel using an oscilloscope. If each axis is aligned in turn close to equipment containing a mains transformer, the stray fields will contain 2nd and 3rd harmonics of the

mains frequency and each channel should give identical results. This will give a rough check on the operation of each channel to a few hundred Hz.

10 MAGNETIC UNITS AND MEASUREMENTS

10.1 CONVENTIONS

The *Mag-03MC* analog output is positive for conventional flux direction South to North in the direction of the arrow given for each axis. The measurement axes are designated X, Y and Z in the Cartesian co-ordinate system when viewed from the top or non-connector end of the sensor.

10.2 MEASUREMENT UNITS

Since 1960 the SI (Systeme Internationale) which is derived from the MKS metric measurement system has been universally adopted. However, measurements are still frequently expressed in the older CGS units. For clarity the following relationships may be useful.

The fundamental equation describing the relationship between magnetic field strength H, magnetic flux density B and the permeability of free space μ_0 is:

$$B = \mu_0 H$$

SI is the preferred system of measurement in this manual and these units, together with their CGS numerical (but not dimensional) equivalents, are shown in the left hand column below.

	SI	=	CGS
B	Wbm ⁻² (Weber per metre ²) or T (Tesla)		10 ⁴ G (Gauss)
H	Am ⁻¹ (Amperes per metre)		4 π x 10 ⁻³ (Oe)

It will be seen that the term 4 π occurs in the CGS units. The SI units, however, are rationalised indirectly by incorporating this term in μ_0 . Thus in the SI system:

$$\mu_0 = 4\pi \times 10^{-7} \text{ Hm}^{-1} \text{ (Henries per metre).}$$

Example: For free space If $H = 80 \text{ Am}^{-1}$

$$\text{Then } B = 4\pi \times 10^{-7} \times 80 \approx 1 \times 10^{-4} \text{ T}$$

Tesla is the preferred unit for flux density in the SI system. A magnetic field sensor can only be said to measure flux density.

10.3 CONVERSION TABLE

The most common conversion performed will be from Tesla to Gauss and vice-versa. The following table may be helpful.

SI	CGS
1 Tesla	10 kGauss
1 mT	10 G
1 μ T	10 mG
1 nT	10 μ G

CGS	SI
1 kGauss	100 mTesla
1 G	100 μ T
1 mG	100 nT
1 μ G	100 pT

TABLE 3 CONVERSION OF SI AND CGS UNITS

10.4 VECTOR MEASUREMENTS

Each axis produces an analog output V_a in response to flux density B in the relationship:

$$V_a = B \cos \varnothing$$

where \varnothing is the angle between the flux direction and the direction of the individual sensing element.

The scalar value of a magnetic field may be computed from the individual X, Y and Z vector components using the RSS (Root of sum of the squares) where:

$$B = (V_x^2 + V_y^2 + V_z^2)^{1/2}$$

It should be noted that there will be a small error in the result of the calculation of the total field due to the small error in the orthogonality between the sensing elements. This will be particularly noticeable when the total field is computed from the values measured with several orientations of the sensor. The sensor is extremely sensitive in the measurement of small variations in the total field provided that the orientation is constant i.e. the detector is stationary. The sensor is therefore limited in applications requiring total field measurement while moving, as in a towed ferrous metal detector, by the orthogonality error within the specified tolerance.

11 TECHNICAL SPECIFICATIONS

11.1 SENSORS

Mechanical, electrical and environmental specifications

	Mag-03MC	Mag-03MCES
Enclosure	reinforced epoxy	reinforced epoxy
Dimensions (mm)	Ø25 x 202 length	Ø25 x 207 length
Mounting	Mag-03MC-BR bracket	Mag-03MC-BR bracket
Connector	Hirose RM15TRD10P	Amphenol 62GB-51T10-7P
Mating connector	Hirose RM15TPD10S	Amphenol 62GB-16J10-7S
Operating temperature		
Continuous	-40°C to +70°C	-40°C to +70°C
Intermittent	-40°C to +85°C	-40°C to +85°C
Weight	85g	85g
Special features		IP64

	Mag-03MCFL	Mag-03MCT
Enclosure	reinforced epoxy	Titanium
Dimensions (mm)	Ø25 x 211 length	Ø25 x 203 length
Mounting	Mag-03MC-BR bracket	Mag-03MC-BR bracket
Connector	Flying leads 500 length **	Hirose RM15TRD10P
Mating connector	(up to 5000 length to order)	Hirose RM15TPD10S
Operating temperature		
Continuous	-40°C to +70°C	-40°C to +70°C
Intermittent	-40°C to +85°C	-40°C to +85°C
Weight	85g	95g
Special features		IP64

	Mag-03MCTP	Mag-03MC-UP
Enclosure	Sensor - Moulded epoxy Electronics - Aluminium alloy	Sensor - Moulded epoxy Electronics - Aluminium alloy
Dimensions (mm)	Electronics - Ø25 x 115 length Sensor - Ø20 x 54 length Sensor - electronics cable - up to 5000 length to order	Electronics - 21 x 12 x 80 length Sensor - Ø20.9 x 56 length Sensor - electronics cable - up to 5000 length to order
Mounting	Mag-03MC-BR bracket	
Connector	Hirose RM15TRD10P	Flying leads 500 length **
Mating connector	Hirose RM15TPD10S	(up to 5000 length to order)
Operating temperature		
Continuous	-40°C to +70°C	-40°C to +70°C
Intermittent	-40°C to +85°C	-40°C to +85°C
Weight	80g	80g

	Mag-03MS	Mag-03MSES
Enclosure	reinforced epoxy	reinforced epoxy
Dimensions (mm)	32 x 32 x 152 length	32 x 32 x 166 length
Mounting	2 x M5 fixing holes	2 x M5 fixing holes
Connector	ITT Cannon DEM-9P-NMB	Amphenol 62GB-12E10-7P
Mating connector	ITT Cannon DEM-9S-NMB	Amphenol 62GB-16J10-7S
Operating temperature	-40°C to +70°C	-40°C to +70°C
Weight	160g	160g
Special features		IP64

	Mag-03MSS
Enclosure	polyacetal
Dimensions (mm)	30x 30x 208 length
Mounting	3 x M3 clearance holes
Connector	Impulse IE XSJ-7-BCR
Mating connector	Impulse IE XSJ-7-CCP
Operating temperature	-10°C to +50°C
Weight	185g
Special features	IP68 Submersible to 100 metres depth

	Mag-03IE	Mag-03IEHV
Enclosure	Sensors - Alumina cylinder Electronics - Aluminium alloy	Sensors - Glass tube with epoxy filling Electronics - Aluminium alloy
Dimensions (mm)	Electronics - Ø25 x 115 length Sensor - Ø8 x 30 length Sensor-electronics cable-750	Electronics - Ø25 x 115 length Sensor - Ø6.5 x 30 length Inner cable - 1100 length (or up to 5000 to order) Outer cable - 140 Inner and outer cable joined by re-solderable terminal block
Mounting	<i>Mag-03MC-BR</i> bracket*	<i>Mag-03MC-BR</i> bracket*
Connector	Hirose RM15TRD10P	Hirose RM15TRD10P
Mating connector	Hirose RM15TPD10S	Hirose RM15TPD10S
Operating temperature		
Continuous	-40°C to +70°C	-40°C to +70°C
Intermittent	-40°C to +85°C	-40°C to +85°C
Weight	80g	80g

	Mag-03IEv1	Mag-03IEv2
Enclosure	Sensors - Alumina cylinder Electronics - Aluminium alloy	Sensors - Alumina cylinder Electronics - Aluminium alloy
Dimensions (mm)	Electronics - Ø25 x 105 length Sensor - Ø8 x 30 length Sensor-electronics cable-750 nominal	Electronics - Ø25 x 105 length Sensor - Ø8 x 30 length Sensor-electronics cable-750 nominal
Mounting	<i>Mag-03MC-BR</i> bracket*	<i>Mag-03MC-BR</i> bracket*
Connector	9-way 'D' type on a 5m cable	25-way 'D' type on a 5m cable
Mating connector	9-way 'D' type	25-way 'D' type
Operating temperature		
Continuous	-40°C to +70°C	-40°C to +70°C
Intermittent	-40°C to +85°C	-40°C to +85°C
Weight	80g	80g

* Bracket is only suitable for electronics enclosure.

** Flying leads are susceptible to EM interference and should be screened wherever possible.

Connector pin out - See Figures for versions with flying leads and full details of all types

<i>Mag-03MC/Mag-03MSS/ Mag-03IE/ Mag-03IEHV/ Mag-03MCTP</i>		<i>Mag-03MS</i>		<i>Mag-03MCES/ Mag-03MSES/ Mag-03MCT</i>	
1	X out	1	+12V supply	A	X out
2	Y out	2	-12V supply	B	Y out
3	Z out	3	signal/power ground	C	Z out
4	signal/power ground	4	signal/power ground	D	signal/power ground
5	signal/power ground	5	Z out	E	signal/power ground
6	+12V supply	6	X out	F	+12V supply
7	-12V supply	7	NC	G	-12V supply
8,9,10	NC	8	Y out		
		9	NC		

<i>Mag-03IEv1</i>		<i>Mag-03IEv2</i>	
1	X out	5	X out
2	Y out	6	Y out
3	Z out	7	Z out
6,7,8	signal/power ground	17,18, 19	signal/power ground
9	signal/power ground	12	signal/power ground
4	+12V supply	11	+12V supply
5	-12V supply	13	-12V supply
		1,2,3,4 ,8,9,10 ,14,15	NC

<i>Mag-03MCFL and Mag-03MCUP</i>	
Colour	Function
Brown	X out
Red	Y out
Orange	Z out
Yellow	signal/power ground
Green	signal/power ground
Blue	+12V supply
Mauve	-12V supply

Note that on Flying Lead versions, leads are susceptible to EM interference and should be screened wherever possible.

Performance specifications (all sensors)

Scaling independent parameters	
Supply voltage	$\pm 12\text{V}$ to $\pm 17\text{V}$
Analog output	$\pm 10\text{V}$ ($\pm 12\text{V}$ supply) swings to within 0.5V of supply voltage
Power supply rejection ratio	$5\mu\text{V/V}$
Output impedance	$< 10\Omega$
Linearity error	$< 0.0015\%$
Output ripple	0 to 1kHz maximally flat, $\pm 5\%$ maximum above 1kHz
Calibration accuracy	$\pm 0.5\%$
Bandwidth	0 to 3kHz (0 to 5kHz for <i>Mag-03IEv1</i> & <i>v2</i> on request)
Orthogonality error - between sensing axes	$< 0.5^\circ$ ($< 0.1^\circ$ for <i>Mag-03MS</i> , <i>Mag-03MSES</i> and <i>Mag-03MCT</i>)
Z axis to reference face	$< 0.1^\circ$ (<i>Mag-03MS</i> and <i>Mag-03MSES</i>)
Single sensor axis to body	$< 3.5^\circ$ (<i>Mag-03IE</i> sensors only)
Internal noise - basic version standard version low noise version	11-20pTrms/ $\sqrt{\text{Hz}}$ at 1Hz 7-10pTrms/ $\sqrt{\text{Hz}}$ at 1Hz $< 6\text{pTrms}/\sqrt{\text{Hz}}$ at 1Hz
Supply current basic & standard versions low noise version	+35mA, -6mA (+1.4mA per 100 μT for each axis) +26mA, -6mA (+1.4mA per 100 μT for each axis)

Scaling dependent parameters								
Measuring range	± 70	$\pm L70$	± 100	$\pm L100$	± 250	± 500	± 1000	μT
Scaling	143	143	100	100	40	20	10	mV/ μT
Offset error	± 5	± 5	± 5	± 5	± 12	± 25	± 50	nT
Scaling temperature coefficient	+15	+15	+20	+20	+50	+100	+200	ppm/ $^\circ\text{C}$
Offset temperature coefficient	± 0.1	± 0.1	± 0.1	± 0.1	± 0.2	± 0.33	± 0.6	nT/ $^\circ\text{C}$

11.2 CABLES

Mag-03MS, Mag-03MSES and Mag-03IE

<i>Conductors</i>	Eight 7/0.2 PVC insulated conductors, overall braided screen and PVC sheath
<i>Type No.</i>	7-2-8c Black to Def Stan 61-12, part 4
<i>Conductor resistance</i>	0.092Ω/m
<i>Capacitance</i>	160pF/m
<i>Alternative</i>	Belden 9538 -5.46mm diameter

Mag-03MC, Mag-03MCES & Mag-03MCT shielded cable

<i>Conductors</i>	Eight 17/0.16 insulated conductors, overall braided screen and flexible PVC sheath
<i>Type No.</i>	Mogami 2690 Screened Cable
<i>Conductor resistance</i>	0.06Ω/m

Mag-03MSS submersible cable

<i>Conductors</i>	3 twisted pairs individually screened, with polyurethane sheath
<i>Type No.</i>	PDM Unelco 3T-SP
<i>Conductor resistance</i>	0.036Ω/m
<i>Weight</i>	0.11kg/m (in air)

Cable connections

SENSOR END						SIGNAL	SUPPLY END
<i>Mag-03MC</i> <i>Mag-03IE</i> <i>Mag-03IEHV</i> <i>Mag-03MCTP</i>	<i>Mag-03IEv1</i>	<i>Mag-03IEv2</i>	<i>Mag-03MS</i>	<i>Mag-03MCES</i> <i>Mag-03MCT</i> <i>Mag-03MSES</i> <i>Mag-03MSFL</i>	<i>Mag-03MSS</i>		
1	1	5	6	A	1	X out	1
2	2	6	8	B	2	Y out	2
3	3	7	5	C	3	Z out	3
4	6,7,8	17,18,19	4	D	4	Signal/Power ground	4
5	9	12	3	E	5	Signal/Power ground	5
6	4	11	1	F	6	+12V supply	6
7	5	13	2	G	7	-12V supply	7
8,9,10		1,2,3,4,8,9, 10,14,15	7,9		8,9,10	NC	8,9,10

For details of cable colours see the figure showing the relevant cable.

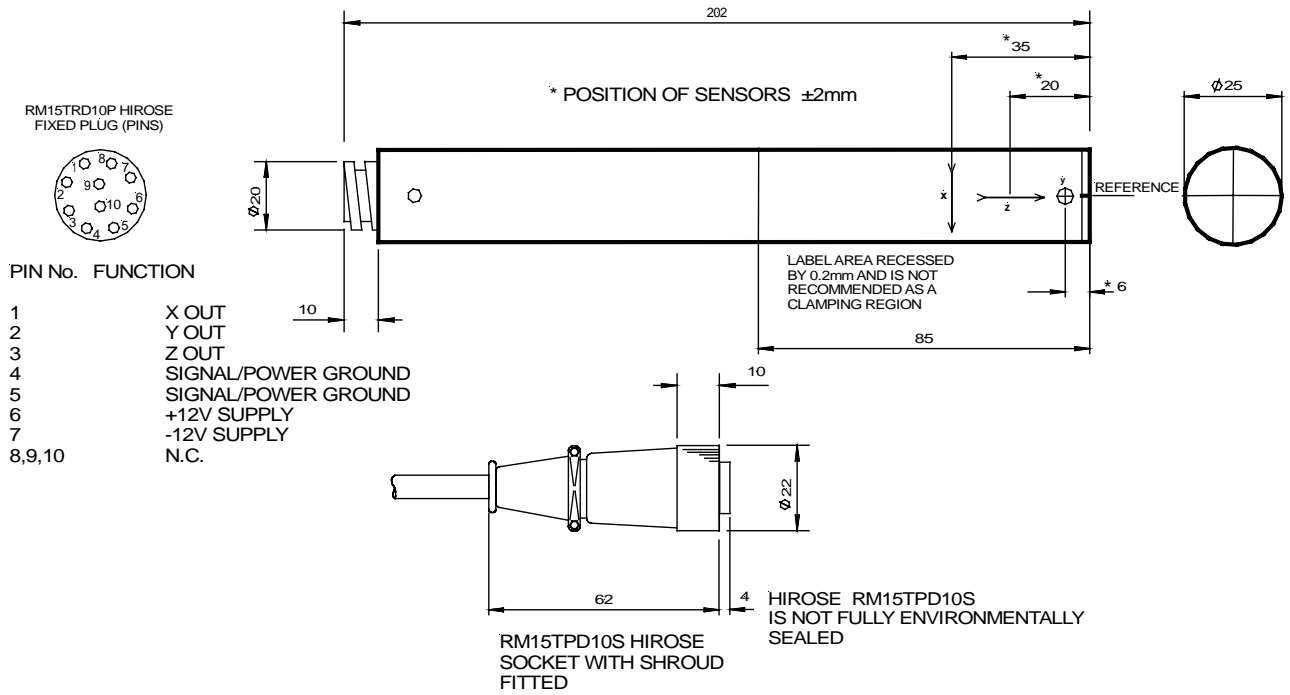

Figure 1 *Mag-03MC* SENSOR OUTLINE WITH MATING CONNECTOR DR0657(3)

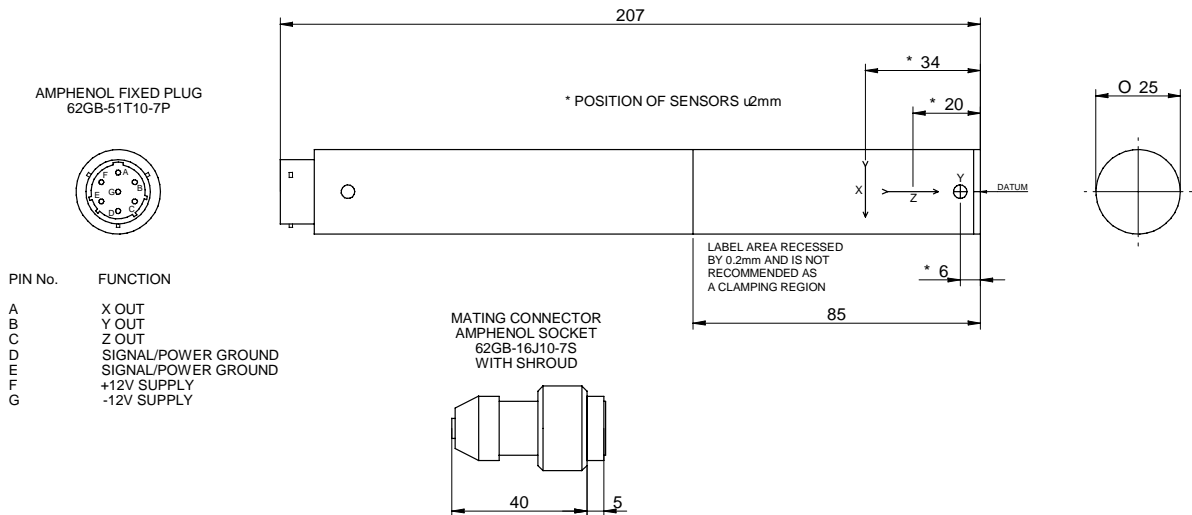
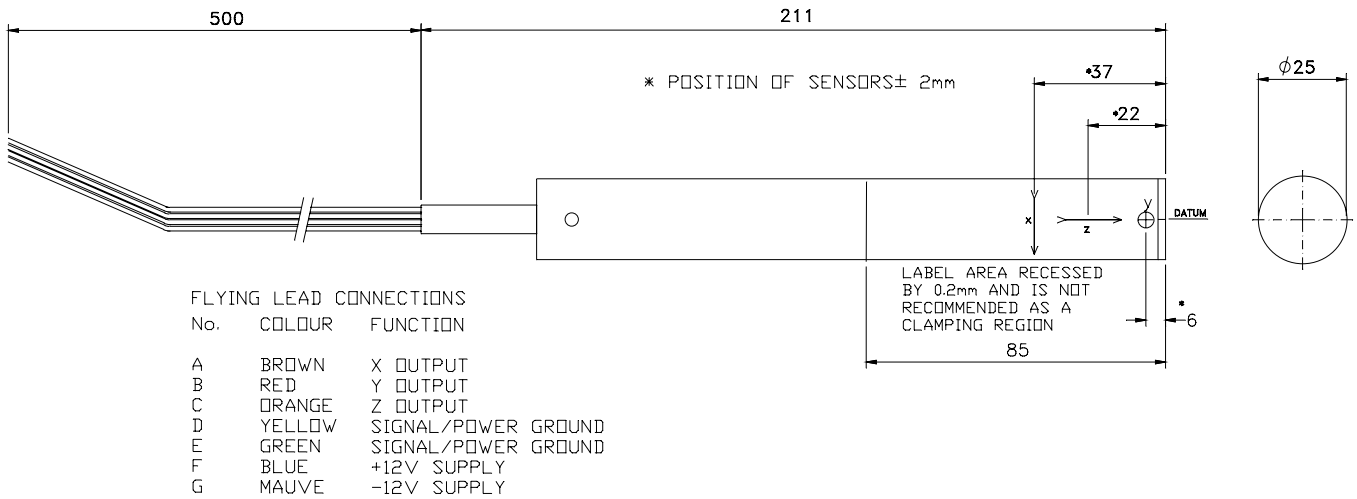

Figure 2 *Mag-03MCES* & *Mag-03MCT* SENSOR OUTLINE WITH MATING CONNECTOR DR0656(2)



Note that flying leads are susceptible to EM interference and should be screened wherever possible.

Figure 3 *Mag-03MCFL* SENSOR OUTLINE DR0745(2)

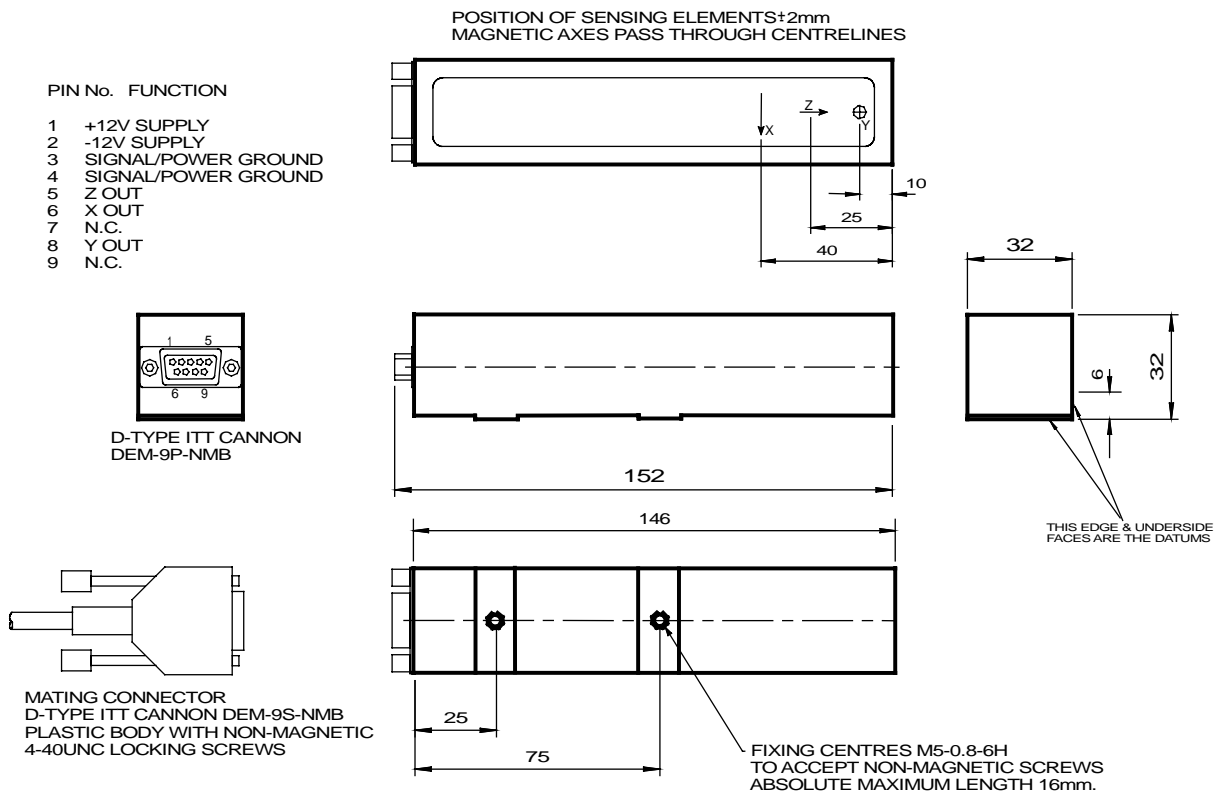

Figure 4 *Mag-03MS* SENSOR OUTLINE WITH MATING CONNECTOR DR0624(3)

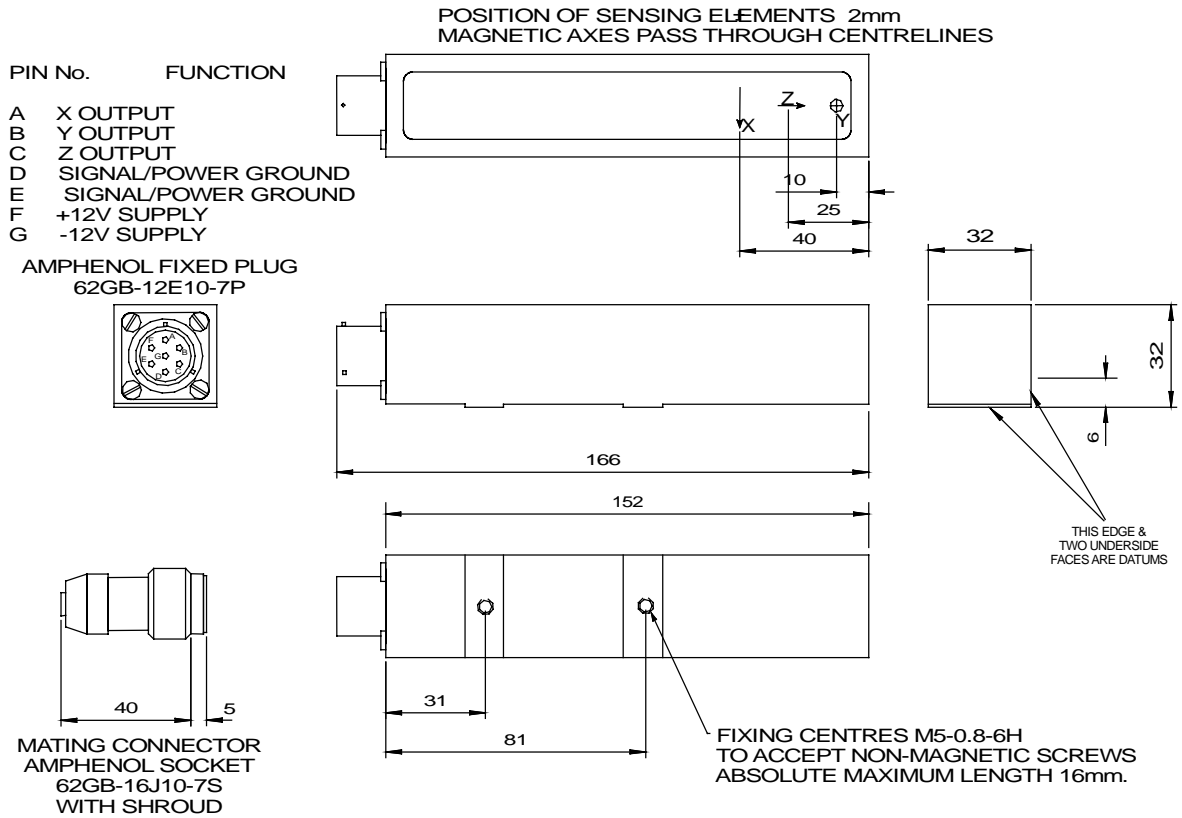

Figure 5 *Mag-03MSES* SENSOR OUTLINE WITH MATING CONNECTOR DR1255(6)

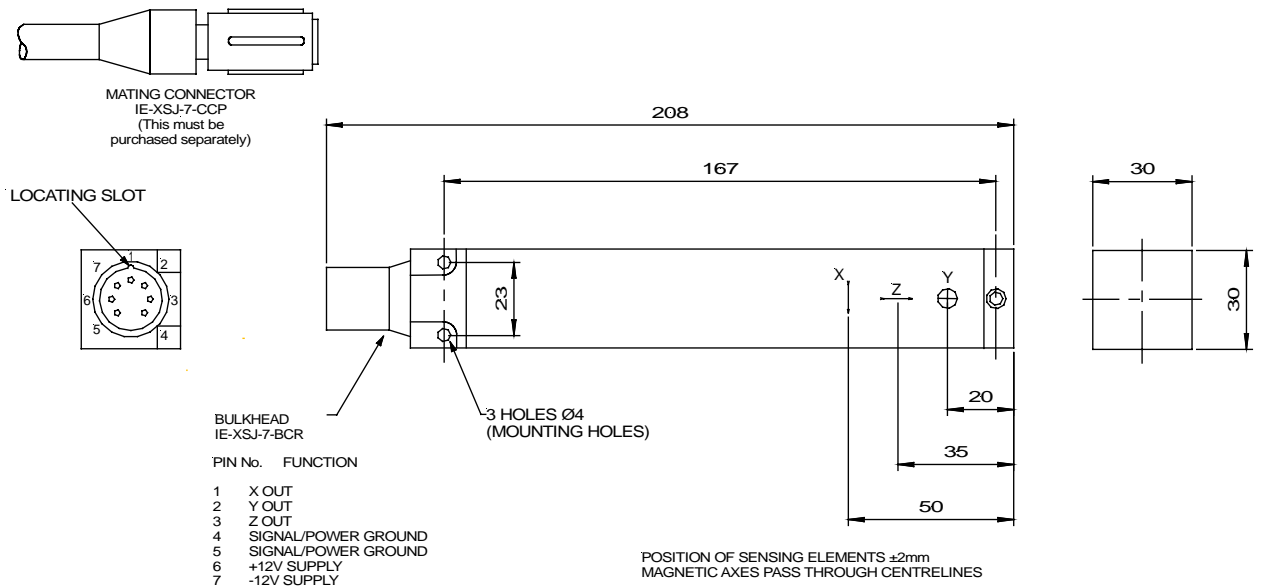

Figure 6 *Mag-03MSS* SENSOR OUTLINE WITH MATING CONNECTOR DR0995(5)

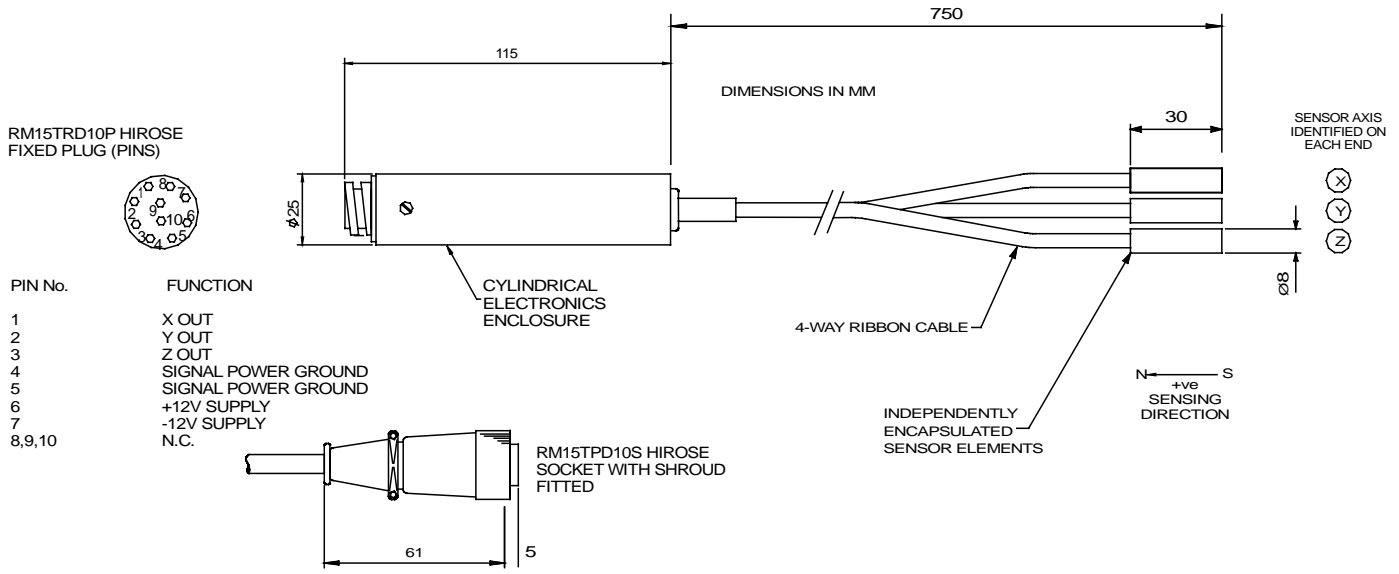

Figure 7 *Mag-03IE* SENSOR OUTLINE WITH MATING CONNECTOR DR0747(3)

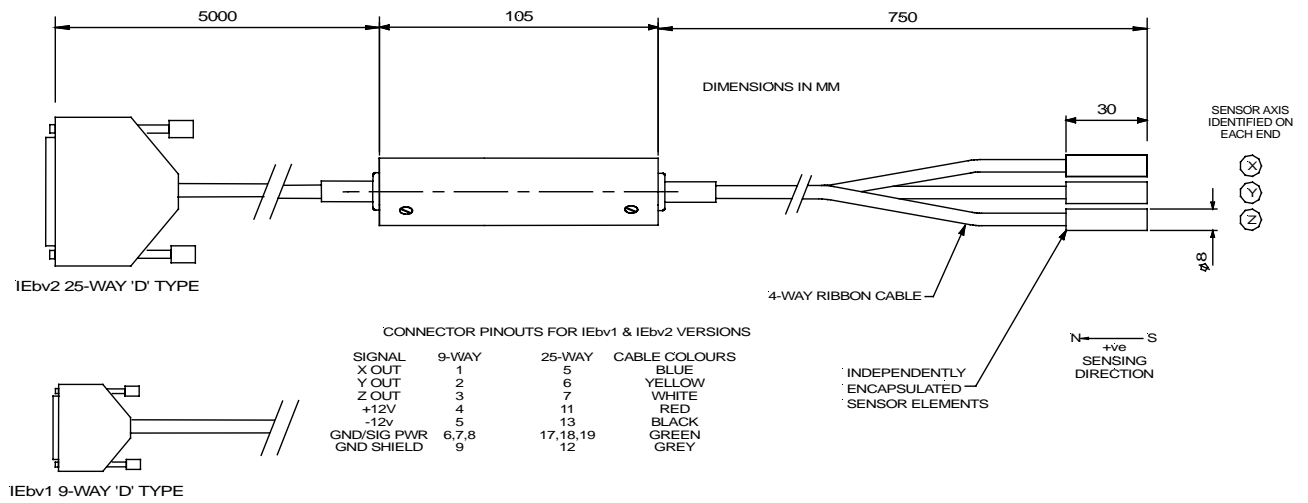

Figure 8 *Mag-03IEv1*, 9-WAY & *Mag-03IEv2*, 25-WAY SENSOR OUTLINE DR1481(4)

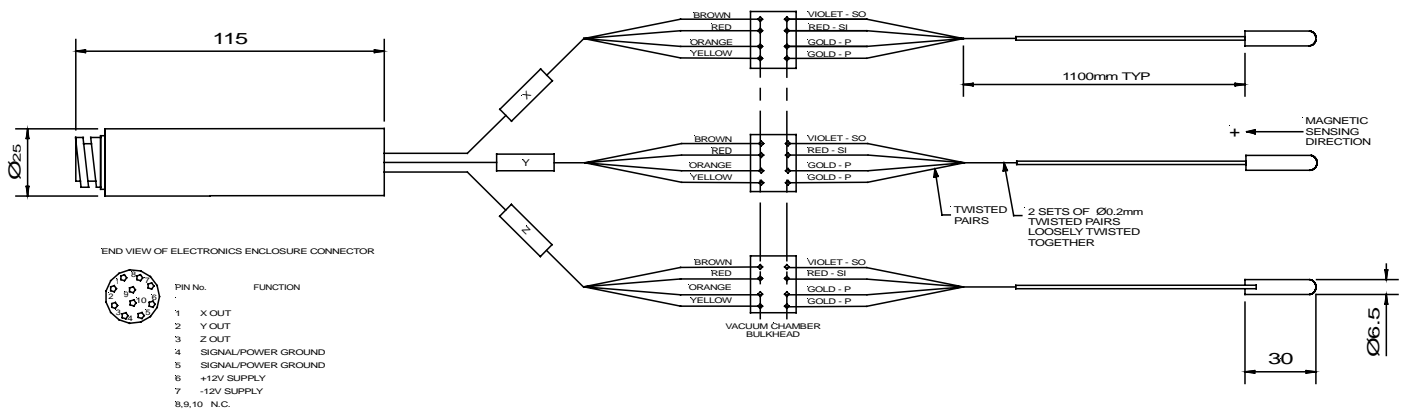

Figure 9 *Mag-03IEHV* SENSOR OUTLINE
DR2311 (1)

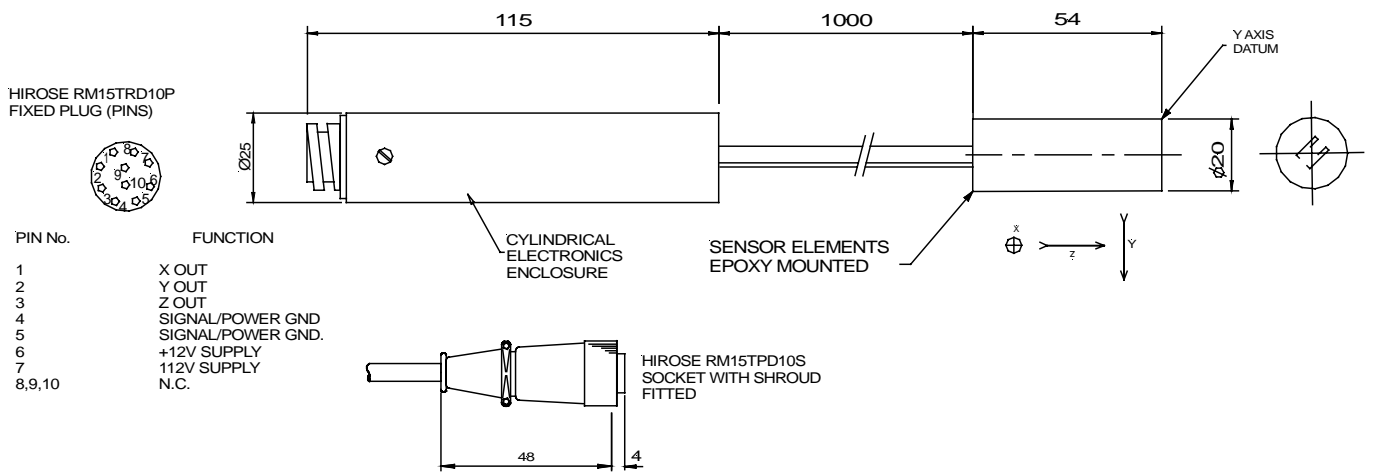
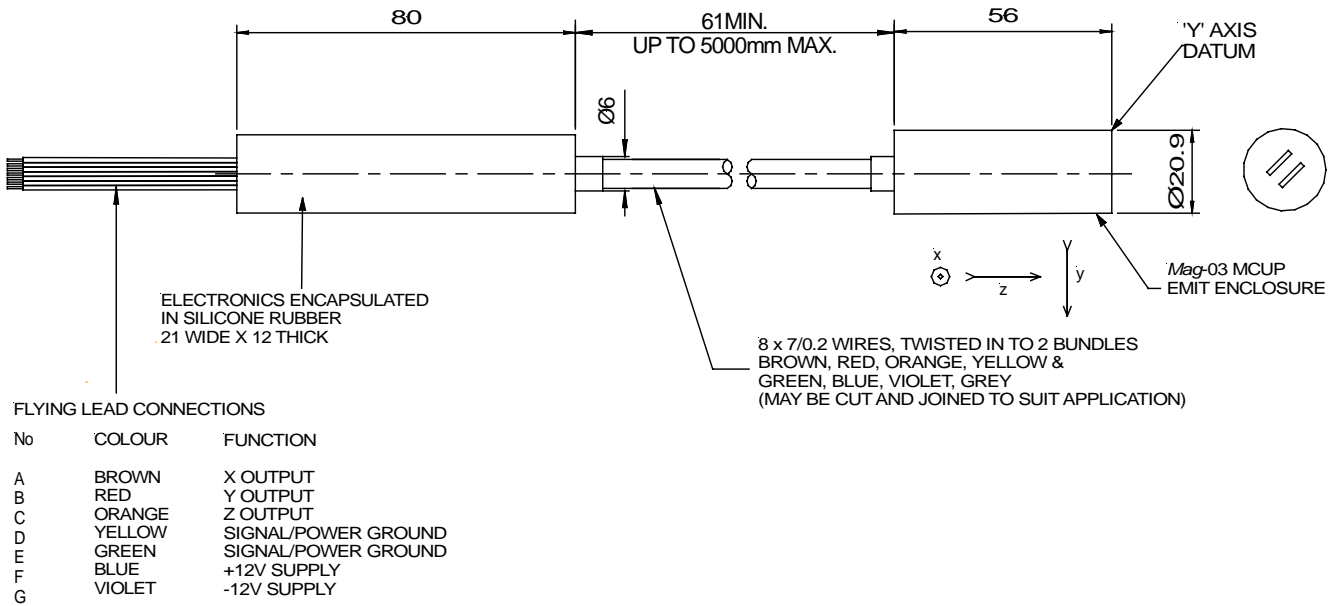

Figure 10 *Mag-03MCTP* VERSION SENSOR OUTLINE WITH MATING CONNECTOR
DR0757(4)



Note that flying leads are susceptible to EM interference and should be screened wherever possible.

Figure 11 *Mag-03MCUP* VERSION SENSOR OUTLINE DR0758(4)

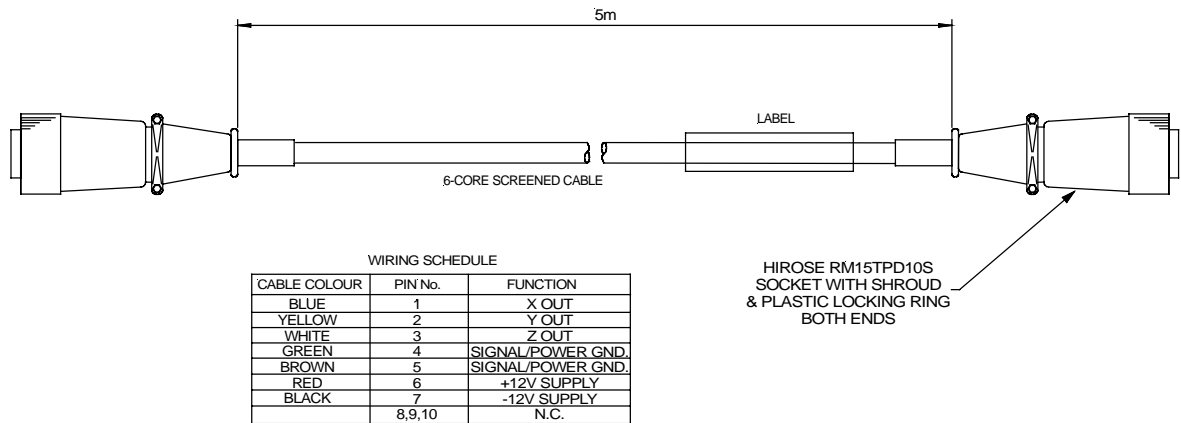
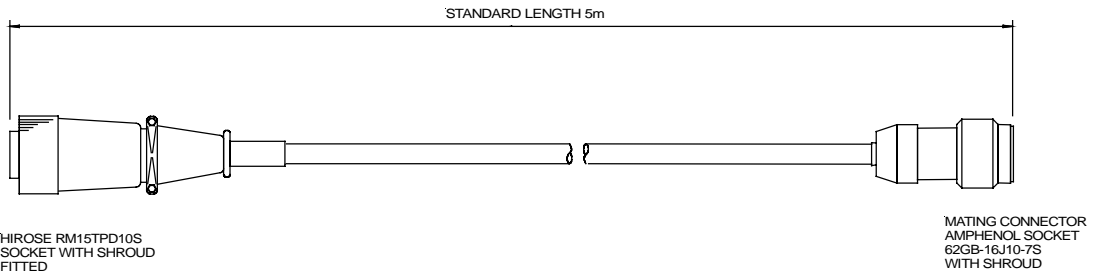

Figure 12 *Mag-03MC* CABLE DR0748(3)



WIRING SCHEDULE

CABLE COLOUR	PIN No.	FUNCTION
BLUE	1	X OUT
YELLOW	2	Y OUT
WHITE	3	Z OUT
GREEN	4	SIGNAL/POWER GND.
BROWN	5	SIGNAL/POWER GND.
RED	6	+12V SUPPLY
BLACK	7	-12V SUPPLY
	8,9,10	N.C.

WIRING SCHEDULE

CABLE COLOUR	PIN No.	FUNCTION
BLUE	A	X OUT
YELLOW	B	Y OUT
WHITE	C	Z OUT
GREEN	D	SIGNAL/POWER GND.
BROWN	E	SIGNAL/POWER GND.
RED	F	+12V SUPPLY
BLACK	G	-12V SUPPLY

Figure 13 *Mag-03MCES & Mag-03MCT* CABLE DR0756(3)

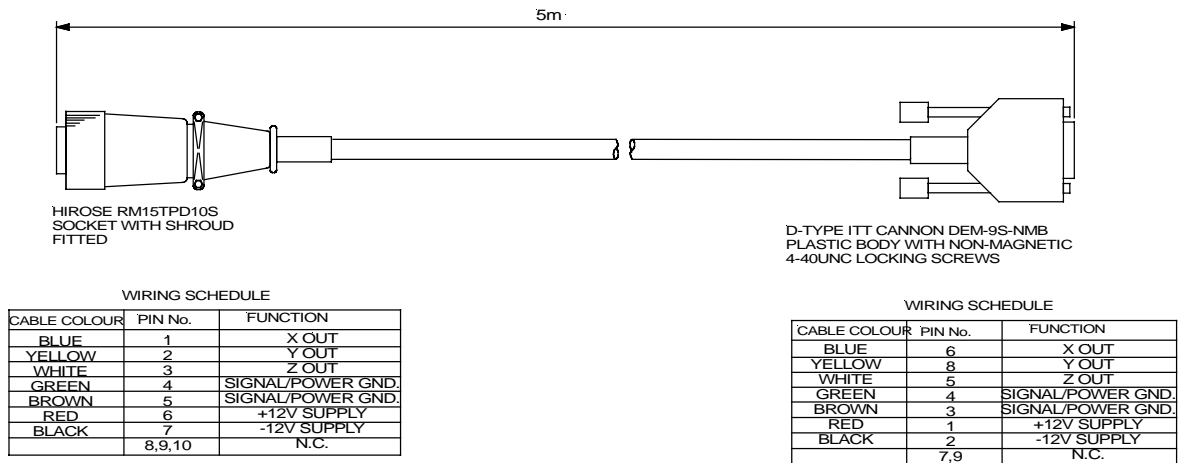

WIRING SCHEDULE

CABLE COLOUR	PIN No.	FUNCTION
BLUE	1	X OUT
YELLOW	2	Y OUT
WHITE	3	Z OUT
GREEN	4	SIGNAL/POWER GND.
BROWN	5	SIGNAL/POWER GND.
RED	6	+12V SUPPLY
BLACK	7	-12V SUPPLY
	8,9,10	N.C.

WIRING SCHEDULE

CABLE COLOUR	PIN No.	FUNCTION
BLUE	6	X OUT
YELLOW	8	Y OUT
WHITE	5	Z OUT
GREEN	4	SIGNAL/POWER GND.
BROWN	3	SIGNAL/POWER GND.
RED	1	+12V SUPPLY
BLACK	2	-12V SUPPLY
	7,9	N.C.

Figure 14 *Mag-03MS* CABLE DR0996(3)

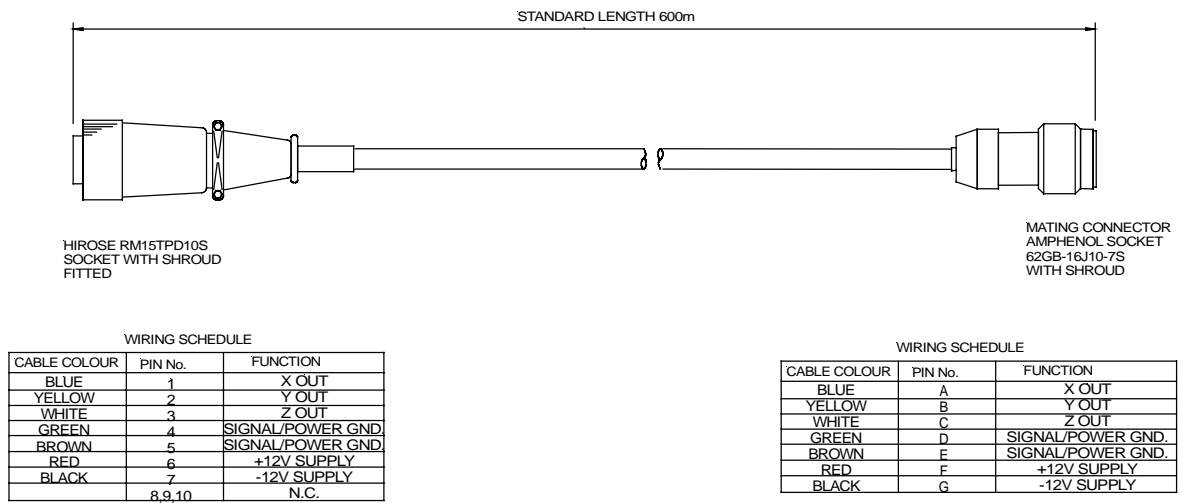

Figure 15 *Mag-03MSES* CABLE DR1257(3)

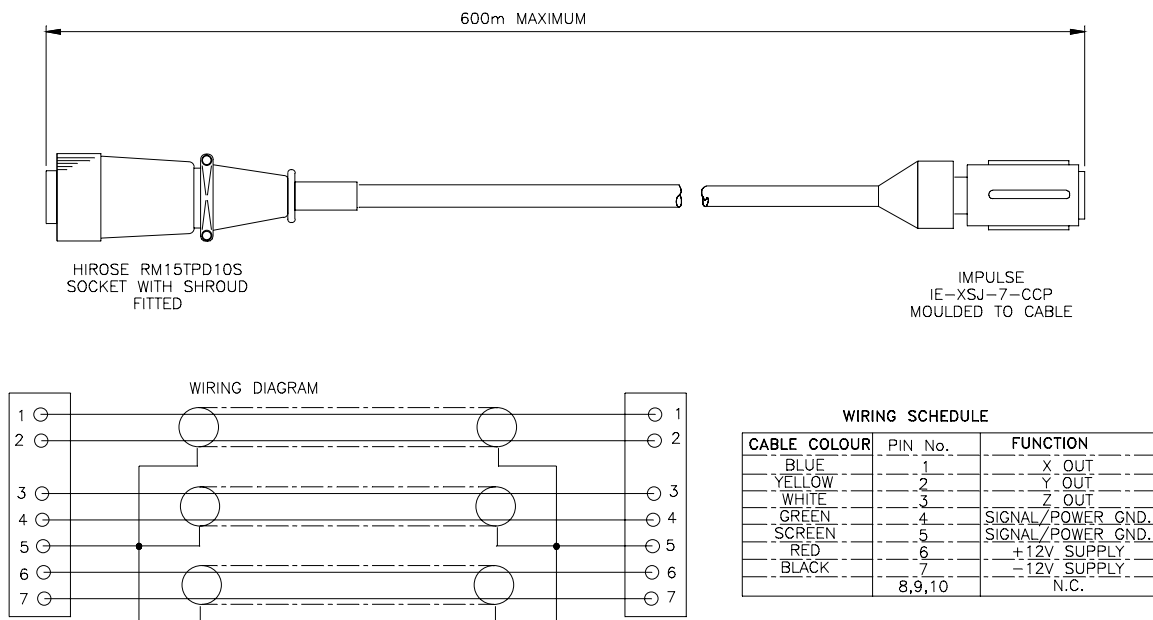

Figure 16 *Mag-03MSS* CABLE DR1017(2)

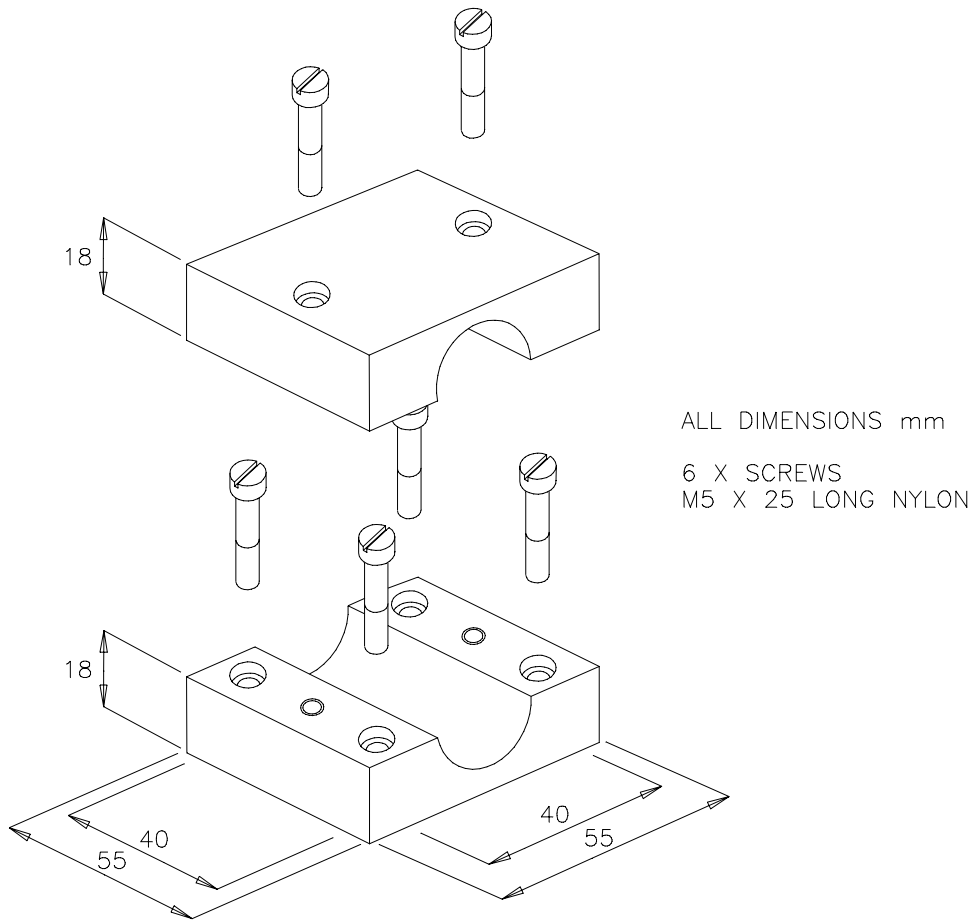

Figure 17 *Mag-03MC-BR* MOUNTING BRACKET DR0746(2)

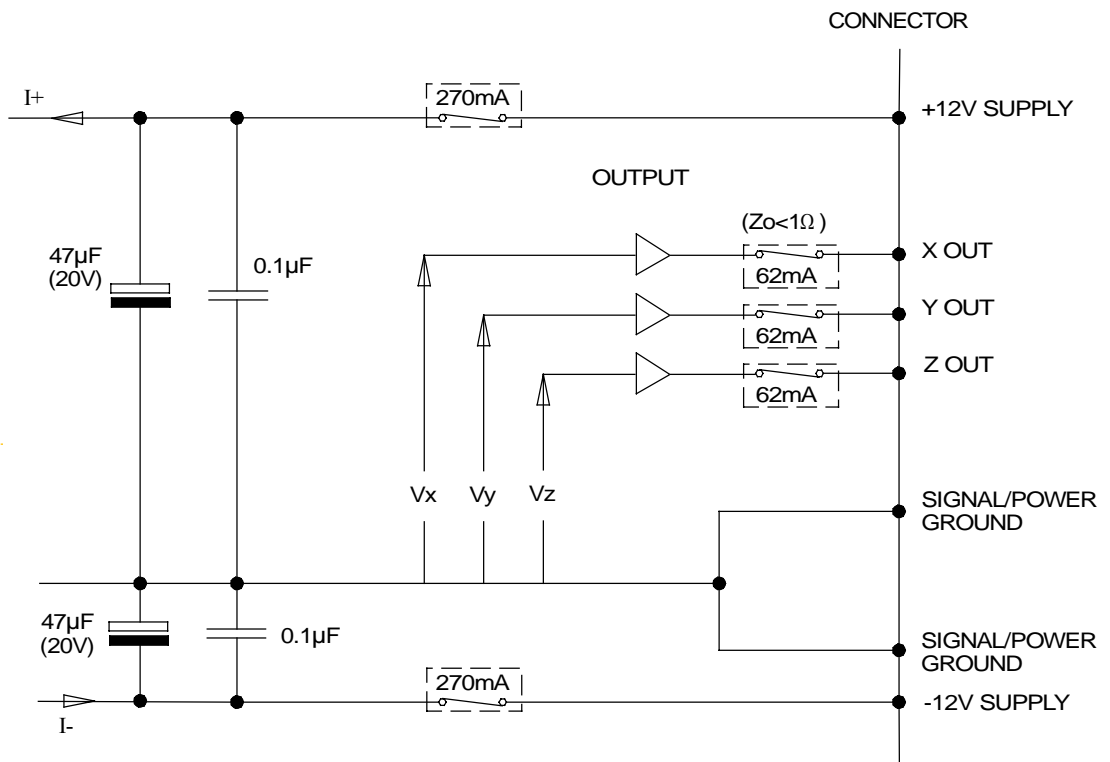

Figure 18 *Mag-03* INTERFACE SCHEMATIC DR1006(3)

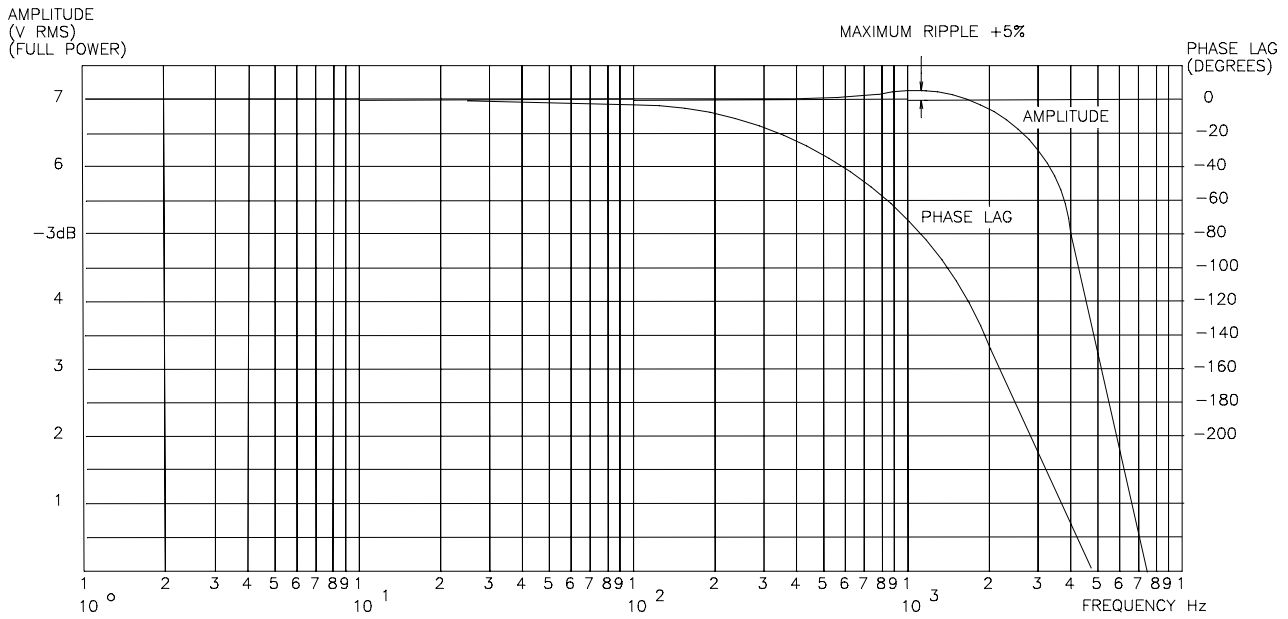

Figure 19 *Mag-03* TYPICAL FREQUENCY DEPENDENT AMPLITUDE & PHASE RESPONSE DR1007(2)

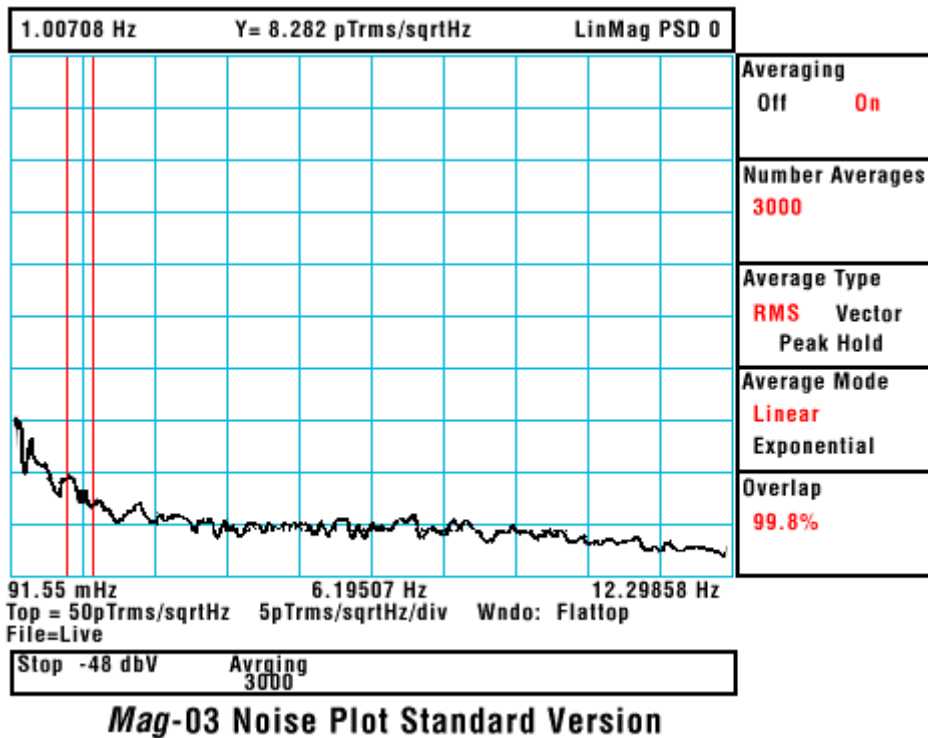
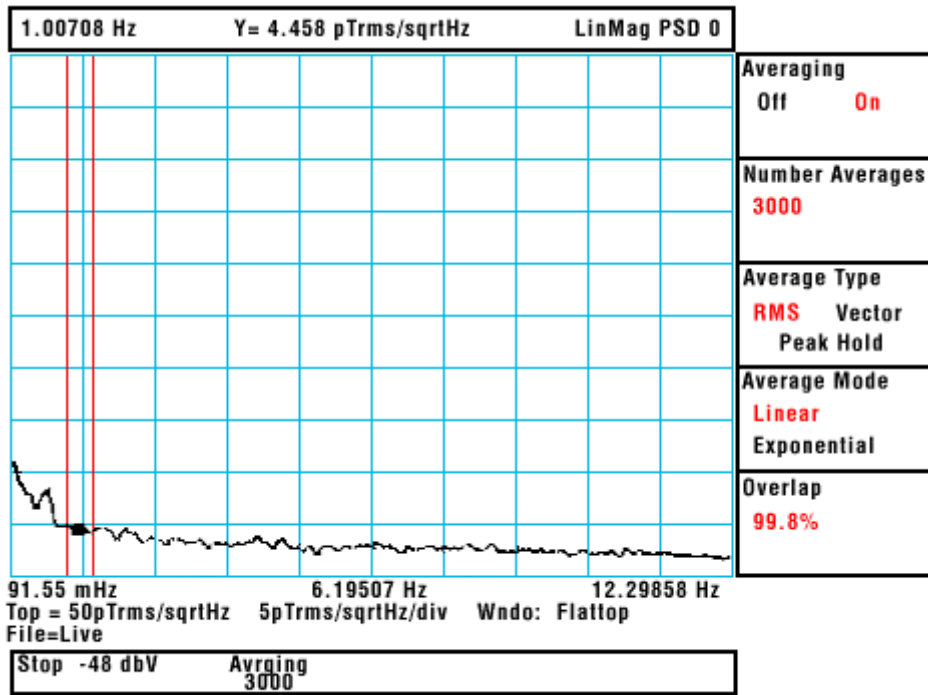

Figure 20 DR1008(2)



Mag -03 Noise Plot Low Noise Version

Figure 21 DR1009(2)