

Newtonian Noise Simulation and Suppression for Advanced Gravitational-Wave Interferometers

Keenan Pepper

August 1, 2007

Newtonian noise

- ▶ Massive black hole mergers and stochastic background are expected to be observed in the 10 Hz region, where Newtonian noise is a problem.
- ▶ Direct gravitational coupling “short-circuits” seismic isolation system.
- ▶ Gravitational force cannot be shielded, so passive isolation is impossible.
- ▶ Active noise cancellation is the way!

AdvLIGO Noise Curve: $P_{in} = 125.0$ W

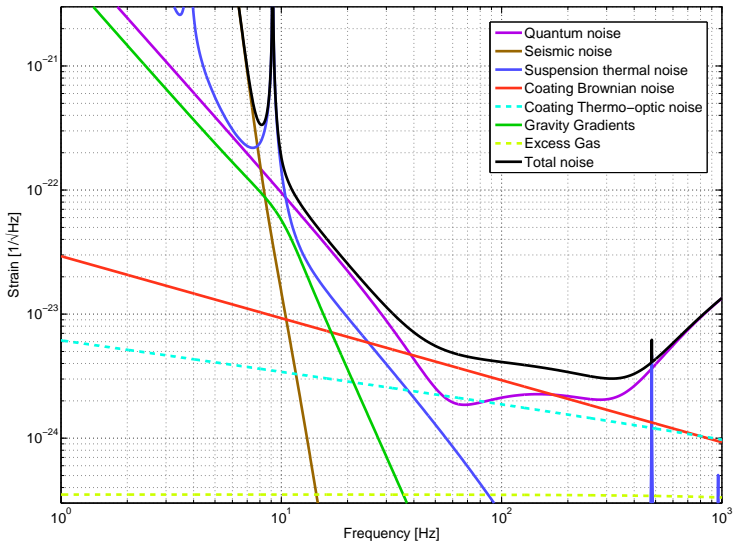

Modeling the BSC

- ▶ Many possible modes of vibration — which should be modeled?
- ▶ Assume the worst: Each point moves so as to maximize the gravitational force along the beam axis.

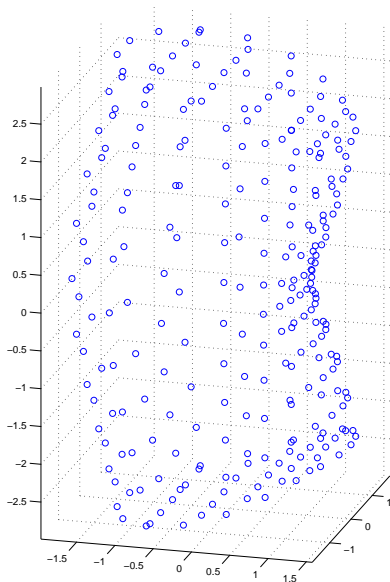

- ▶ Not a physically reasonable mode of vibration (although similar to a folding mode), but a limiting case.
- ▶ Mass of 8 tonnes results in gravity coefficient of 10^{-7} s^{-2} , i.e., for every micron of deflection, the acceleration of the test mass changes by 10^{-7} microns per second squared.

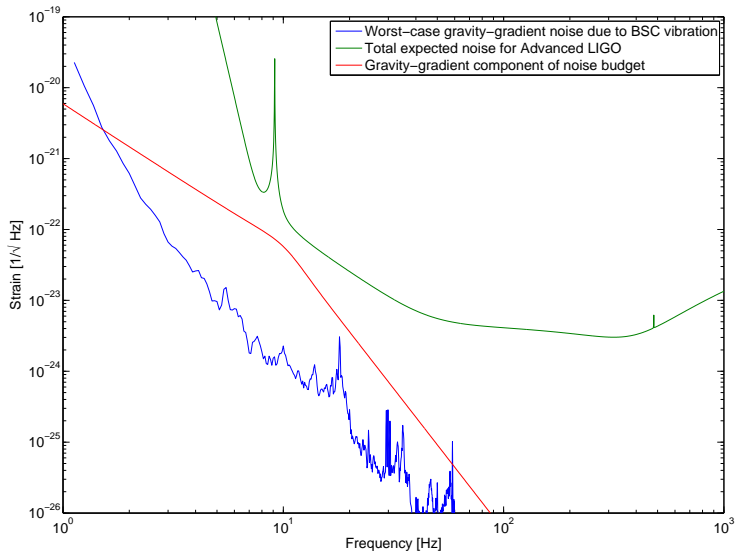

eigfreq_sld(1)=12.847981 Boundary: Total displacement [m] Deformation: Displacement [m]

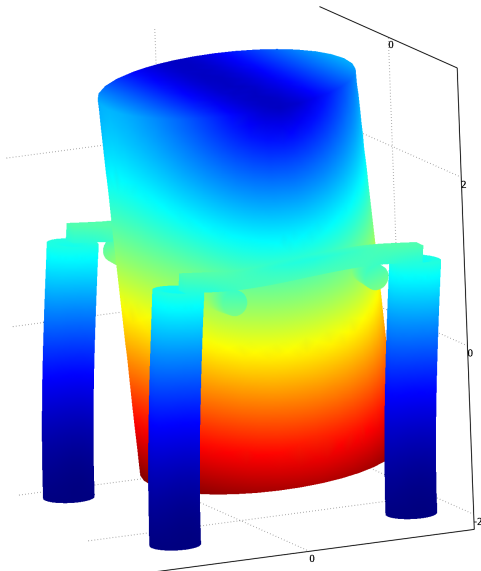

- ▶ Swinging mode predicted at 13 Hz
- ▶ Gravity coefficient $1.5 \times 10^{-8} \text{ s}^{-2}$ (compare to 10^{-7} s^{-2} for worst case model, $1.8 \times 10^{-7} \text{ s}^{-2}$ for both following slab modes)

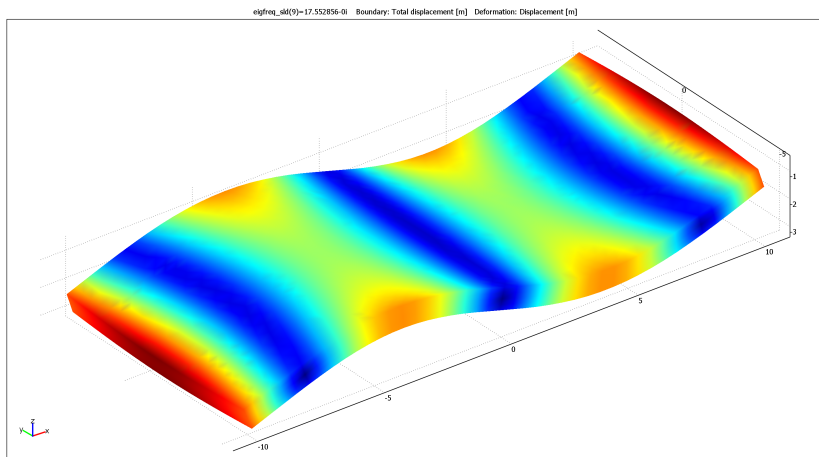

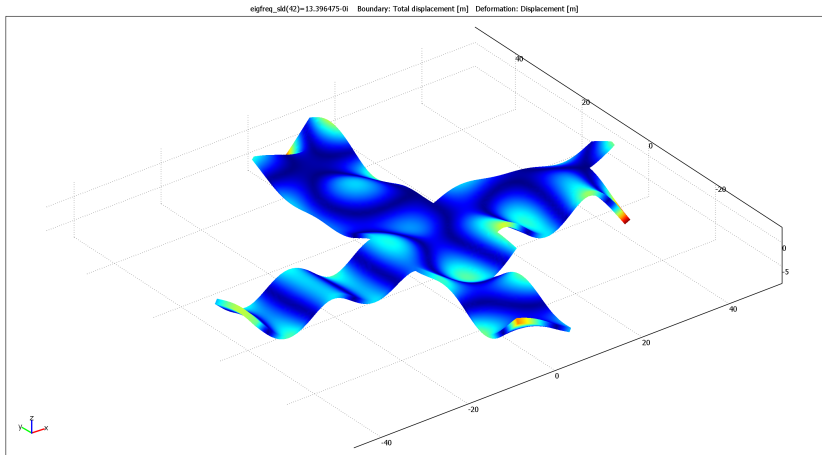

Cancelling the noise

- ▶ Cannot simply subtract accelerometer data from suspension data, because it is filtered through an unknown transfer function.
- ▶ To approximate this transfer function, we can use an optimal filter.
- ▶ This approach is also used in acoustic applications, e.g. noise cancelling headphones.

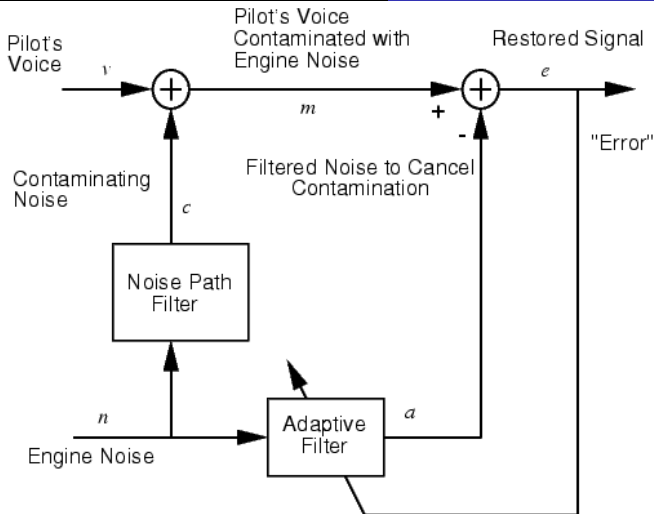

Adaptive Filter Adjusts to Minimize Error.
This removes the engine noise from contaminated
signal, leaving the pilot's voice as the "error."

Static filters

Static coefficients

Require representative data

Hard to construct, easy to apply

FIR Wiener, IIR Wiener

Adaptive filters

Dynamically updated

Can be started anywhere

No separate construction phase

LMS, NLMS, RLS, PNLMS...

- ▶ Adaptive IIR filters are tricky and not yet well understood, but they may be particularly useful for low-frequency noise cancellation.

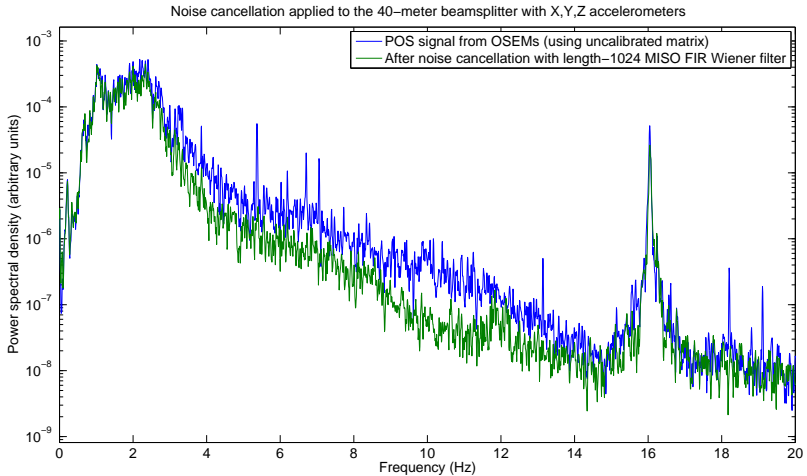

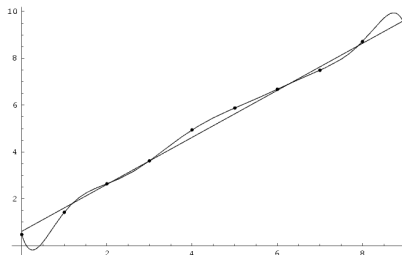

- ▶ Overfitting results when a model has too many parameters and not enough data.
- ▶ For example, when an FIR filter has almost as many taps as input samples.

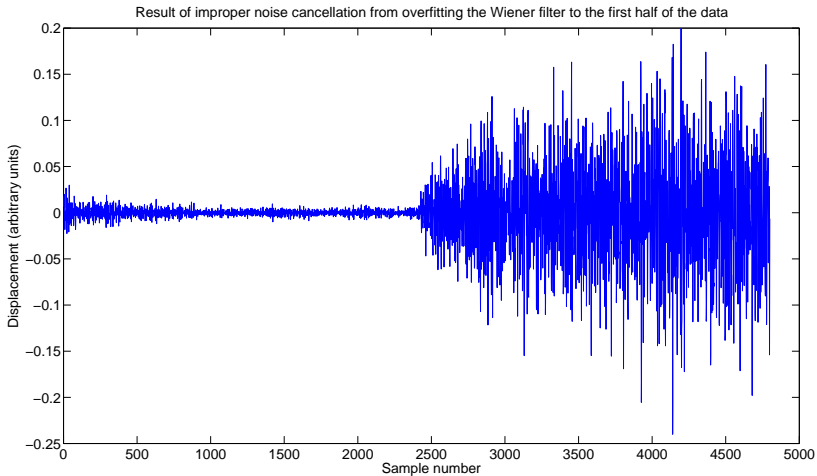

- ▶ Find out how to inject realistic noise into COMSOL model and use virtual accelerometers to evaluate strategies (how many do we need, where should we put them...).
- ▶ Implement different adaptive filter algorithms and compare their performance.
- ▶ Investigate adaptive IIR filters.