

LASER INTERFEROMETER GRAVITATIONAL WAVE OBSERVATORY
- LIGO -
CALIFORNIA INSTITUTE OF TECHNOLOGY
MASSACHUSETTS INSTITUTE OF TECHNOLOGY

Technical Note

LIGO-T080202-00-R

Date: 2008/09/02

**Development of Auxiliary Lock
Acquisition Procedures at the
Caltech 40m Interferometer**

Masha Baryakhtar

Mentors: Rana Adhikari and Alan Weinstein

California Institute of Technology
LIGO Project, MS 18-34
Pasadena, CA 91125
Phone (626) 395-2129
Fax (626) 304-9834
E-mail: info@ligo.caltech.edu

Massachusetts Institute of Technology
LIGO Project, Room NW22-295
Cambridge, MA 02139
Phone (617) 253-4824
Fax (617) 253-7014
E-mail: info@ligo.mit.edu

LIGO Hanford Observatory
Route 10, Mile Marker 2
Richland, WA 99352
Phone (509) 372-8106
Fax (509) 372-8137
E-mail: info@ligo.caltech.edu

LIGO Livingston Observatory
19100 LIGO Lane
Livingston, LA 70754
Phone (225) 686-3100
Fax (225) 686-7189
E-mail: info@ligo.caltech.edu

Abstract

A crucial step in an operational gravitational wave detector is lock acquisition, the process of bringing optical cavities to resonance and locking the detector, making it sensitive to gravitational wave signals. The narrow linear regime of the error signal makes the process of lock acquisition at LIGO a challenge; random motion is largely relied on to bring degrees of freedom into range of the servo. In Advanced LIGO, acquiring lock will become even more challenging with addition of a fifth degree of freedom, so a reliable auxiliary lock acquisition system becomes crucial for operation. This report describes an auxiliary lock method that uses laser light distinct from the main beam to control arm cavity lengths via frequency doubled Pound Drever Hall locking. The accuracy required of the system is set by the necessary cavity length precision, and noise limits of components of the system are presented and analyzed in this context. Passing laser light through an optical fiber to the point of injection into detector arms introduces phase noise on the light and is the limiting noise source. Fiber noise levels were measured with a Mach Zehnder interferometer and found to exceed limits set by desired locking precision. A fiber noise cancellation scheme is being implemented, and is expected to reduce noise below desired levels.

Contents

1	Background and Motivation	3
1.1	Outline	3
2	Auxiliary Locking	5
2.1	Frequency Doubled PDH Locking	5
2.2	Noise Sources	7
3	Fiber Stabilization	8
3.1	Measuring Fiber Noise	8
3.1.1	Experimental Setup	8
3.1.2	Noise Sources	9
3.1.3	Fiber noise measurements	13
3.2	Canceling Fiber Noise	14
3.2.1	Noise sources in the system	16
3.2.2	Experimental Setup	16
4	Future Work	17
5	Summary and Conclusion	19
A	Methods	20
A.1	Derivation of Mach Zehnder output signals	20
B	LIGO Acronyms	21

1 Background and Motivation

The Advanced LIGO upgrade will increase the sensitivity of the current gravitational wave detectors and enable observation of sources not accessible to initial LIGO. Prior to operation of the detector, the system is in an uncontrolled state; in order to collect data, the optical elements must be brought close to resonance and locked. Once the system is locked, feedback signals to the optics can maintain each degree of freedom (DOF) at the operating point, making the detector sensitive to the length perturbations caused by gravitational waves[1]. Currently, the random motion of each of the test masses - interferometer mirrors - is relied on to bring each of the four DOF within range of the locking servo. With the upgrade to Advanced LIGO, another DOF will be added to the system, making this technique much more inefficient than it is even today. It is important that the time required for lock acquisition is short, such that the time the detector is available for taking data is not significantly affected [2]. To achieve this, the process of acquiring lock must be made more deterministic and robust. The Caltech LIGO 40m interferometer prototype gravitational wave detector, operated by the LIGO Laboratory, is designed for optimizing techniques and modeling the performance of the LIGO detectors and for developing and testing new elements for the Advanced LIGO design. The lock acquisition work at the 40m interferometer will determine how the Advanced LIGO interferometers are locked.

The current method of lock acquisition at the 40 meter is based on a procedure in which the five different DOF (Figure 1) are sequentially brought to resonance [1]. As the states of the DOF cannot be independently measured in the output signals available, it is difficult to calculate the required feedback from this information. From the experience at the 40m interferometer, the process is time consuming and unreliable. Locking the two arms takes the majority of the waiting time, when the random motion of the arms has to bring each arm within a transmission resonance of the cavity. To make this process more robust and consistent, it is necessary to decouple these two degrees of freedom from the rest of the system and be able to independently and reliably control them.

Several techniques have been proposed to sense and control the DOF [3]. Frequency shifted Pound Drever Hall (PDH) locking is the most promising of these schemes, as it is reliable, requires only minor modifications, and is based on the Pound Drever Hall technique [4] that is already widely employed at LIGO and elsewhere. This scheme is presented below.

1.1 Outline

The first section of this paper describes the steps required to successfully lock the arm of the interferometer using the frequency shifted PDH auxiliary locking scheme. The potential noise sources and their effect on the auxiliary lock system are discussed.

The second section of the paper describes the technique and implementation of canceling phase noise caused by transferring laser light over long distances via optical fiber. This is necessary for the proposed method of auxiliary locking, as the PSL frequency reference must be transferred to the end stations 4 km away for Advanced LIGO for injection into the arms. The characteristics of the fiber noise are presented. A fiber phase noise cancellation technique [5] is described, and preliminary tests of this technique are presented.

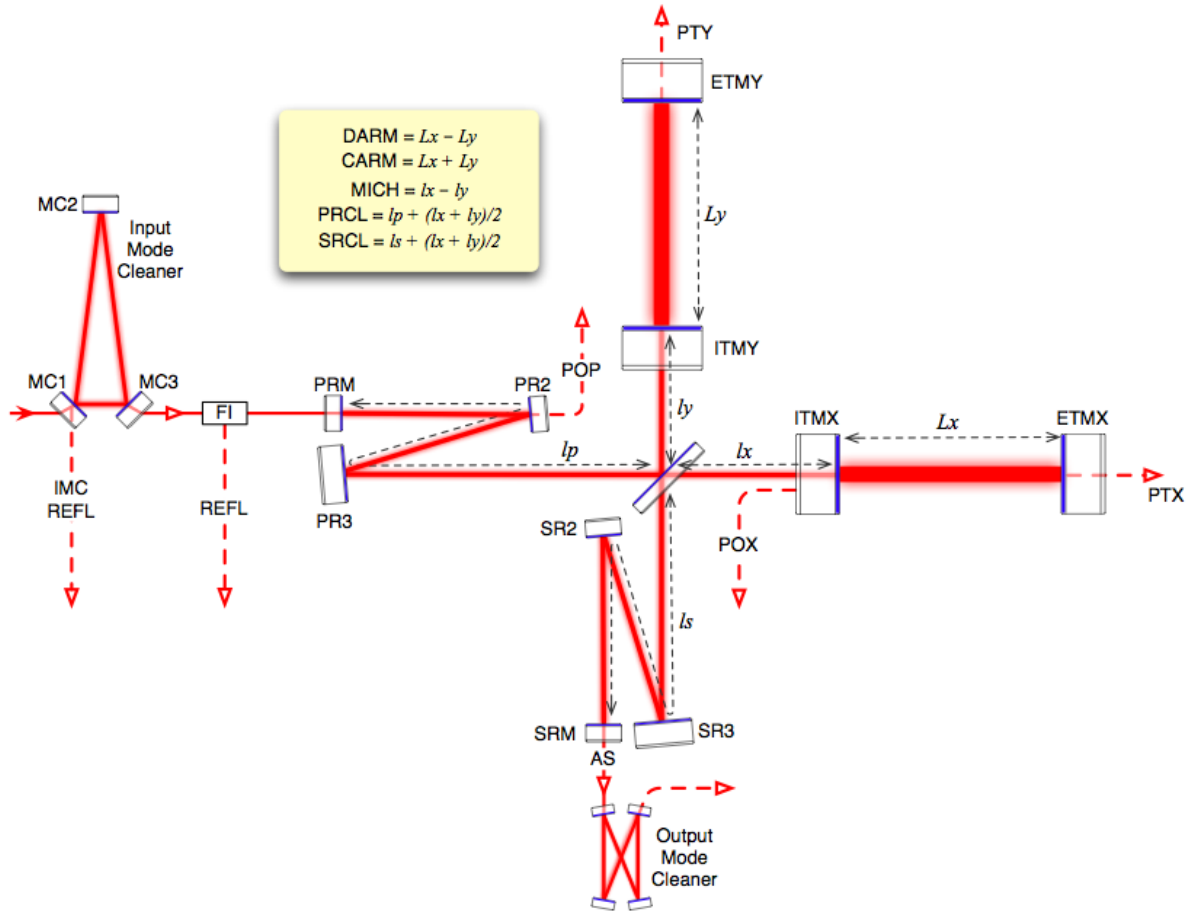

Figure 1: LIGO interferometer[2]. The five degrees of freedom are $DARM = L_x - L_y$, $CARM = L_x + L_y$, $MICH = l_x - l_y$, $PRCL = l_p + (l_x + l_y)/2$, and $SRCL = l_s + (l_x + l_y)/2$. The goal of this auxiliary locking scheme is to independently control arm cavity lengths L_x and L_y .

2 Auxiliary Locking

In order to improve the lock acquisition procedure, an auxiliary locking technique will be used - a novel approach in which auxiliary laser light, distinct from the main laser beam, is injected into the interferometer to obtain better length sensing signal to aid in lock acquisition. In the proposed method, green light (wavelength 532 nm) injected into the end test masses will be used in the Pound Drever Hall technique of locking a cavity to a stable frequency reference[4]. The PDH signal will provide a means of sensing and controlling the arm cavity lengths, decoupling them from the rest of the system and greatly increasing the efficiency of the locking process.

2.1 Frequency Doubled PDH Locking

To control the length of the arm cavities and improve the locking process, the lengths L_x and L_y will each be locked to a stable frequency reference using Pound Drever Hall. The goal is to control arm motion within half a cavity resonance at the 1064 nm wavelength, because in this domain the primary lock servo is active. Even with the isolation systems reducing the motion of the test masses, the total test mass motion due to ground motion and other environmental factors is on the order of a few μm , so the cavities need to be stabilized further, especially at low frequencies where ground motion is dominant. Beyond several hundred Hz, the ground motion noise becomes negligible. Thus, this locking scheme focuses on frequencies of 1 mHz through 1 kHz, the tentative cutoff frequency of the fiber stabilization servo.

The 532 nm wavelength of the carrier light was selected for several reasons. The wavelength must be distinct from the main beam at 1064 nm in order to be able to decouple the arms from the rest of the system. At 532 nm, the index of refraction of the masses is different enough such that the arms become completely decoupled from the rest of the system: that is, if light is injected from the end test masses, any light transmitted past ITMX and ITMY does not reenter the arms due to the large wedge angles, so the light resonating in the arm cavities does not interact with the rest of the system. It has been shown [6] that the mirror coatings can be modified to achieve a finesse as high as 30 for the green light while preserving the high finesse and low thermal noise at 1064 nm (Figure 2). A finesse lower than that at 1064 nm ($\mathcal{F} = 400$ at 1064 nm) is necessary to broaden the range of the auxiliary error signal compared with the primary error signal. In addition, this frequency makes use of the already existent and extremely stable PSL light by frequency doubling from 1064 nm.

In the proposed method, the auxiliary beam is frequency doubled to 532 nm by single passing a periodically poled KTP (PPKTP) crystal. The PPKTP is single passed for simplicity, and in order to reduce the possibility of introducing additional phase noise. The doubled frequency prevents interaction of the auxiliary laser light with the PSL and enables an independent measurement of arm cavity lengths without interaction with the power recycling cavity [3]. The light will be injected through the end test masses (ETMs) into the arm cavities (Figure 1), thereby decoupling the arms from the rest of the system. The main challenge is to obtain a stable frequency reference at the end stations for use in PDH. In order to achieve this, pickoffs from the PSL will be sent via optical fiber to ETMX and ETMY. At the end stations, the light delivered through fiber will be used in a phaselock loop to stabilize a 1W

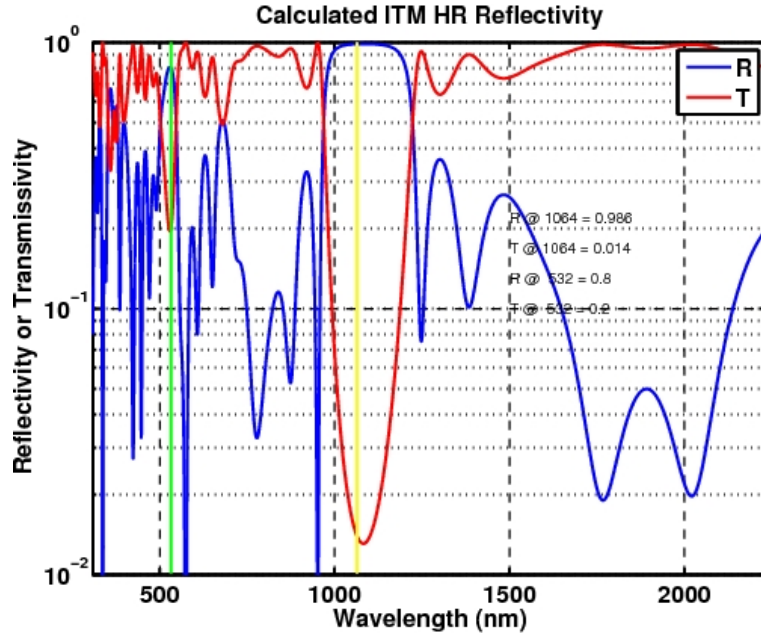

Figure 2:

1064 nm laser. The 1W laser will subsequently be frequency doubled to obtain 10 mW of 532 nm light, which will be used to control the arm lengths (L_x and L_y in Fig 1) using a feedback signal generated by the Pound Drever Hall technique[4]. Independently sensing and controlling L_x and L_y provides a direct method to lock two of the degrees of freedom of the interferometer, and is a key step in bringing the entire system into lock and able to perform measurements (Figure 3).

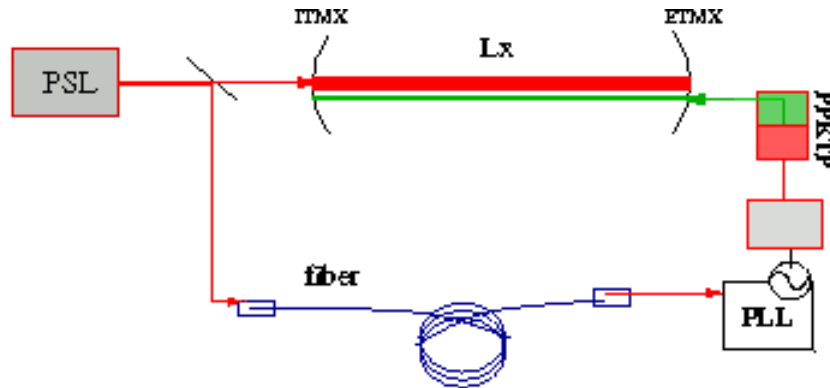

Figure 3: Frequency doubled PDH scheme: a pickoff from the PSL is transferred to the end stations, e.g. ETMX. The output of the fiber is used to stabilize a 1W 1064 nm laser via a phaselock loop (PLL). The 1W laser is then frequency doubled to 532 nm using a periodically poled KTP (PPKTP) crystal and injected into ETMX.

2.2 Noise Sources

The required cavity length precision is set by the linewidth of the Fabry-Perot resonances, given by $\lambda/2\mathcal{F}$, where λ is the wavelength of the light and \mathcal{F} is the finesse of the cavity. For Advanced LIGO, $\lambda = 1064$ nm and $\mathcal{F} = 400$, which gives a linewidth of 1.33 nm that is far smaller than the several μm caused by ground motion. Keeping the cavities within half a linewidth of resonance sets a limit on the rms arm length motion of 0.67 nm. For a cavity, the relative frequency noise and relative length noise are equivalent, so

$$\frac{\delta f}{f} = \frac{\delta L}{L} \quad (1)$$

Then the goal for the total rms frequency noise in the laser to be used in Pound Drever Hall locking, given by:

$$\delta f = f \cdot \frac{\delta L}{L} \quad (2)$$

where L is the cavity length, f is the laser frequency, and δL is the desired maximum deviation of cavity length from resonance. For Advanced LIGO arm lengths of $L = 4$ km, the maximum frequency noise is $\delta f = 50$ Hz rms.

(also should probably calculate for 40m specs)

Although the PSL laser frequency noise is low enough at $10 \text{ Hz}/\sqrt{\text{Hz}}$ [7], there are multiple noise sources in the auxiliary locking system which broaden the laser bandwidth and put a limit on the effectiveness of PDH locking stability. The main noise sources are outlined below, and the major concern of fiber phase noise is then treated in more detail in the following section.

- Shot Noise

The shot noise limited sensitivity in a Pound Drever Hall locking system is given by [4]:

$$S(L) = \frac{\sqrt{hc}}{8} \frac{\sqrt{\lambda}}{\mathcal{F}\sqrt{P_c}} \quad (3)$$

$$S(f) = \frac{\sqrt{hc}}{8} \frac{\sqrt{\lambda}}{\mathcal{F}\sqrt{P_c}} \frac{f}{L} \quad (4)$$

where λ is the light wavelength, \mathcal{F} is the finesse of the cavity and P_c is the power of the carrier in PDH locking. For the Advanced LIGO specifications of $\mathcal{F} = 30$ and $P_c = 10$ mW at 532 nm, the shot noise limited length sensitivity is 2×10^{-6} Hz, the lowest achievable noise floor and well below the stability goal of 50 Hz.

- Fiber phase noise

The transmission of a stable frequency reference through a fiber introduces phase noise, as the fiber's phase is very sensitive to environmental perturbations: dominantly

acoustic fluctuations, as well as changes in temperature and pressure, affect the phase of the light output from the fiber [5]. The stability of the laser to be used for PDH sets a limit of 50 Hz rms on the amount of frequency noise that can be generated by transmission of the stable PSL pickoff through the fiber. It has been shown that it is possible to effectively cancel the fiber induced phase noise [5]. The technique of noise cancellation will be tested and implemented in the context of the auxiliary lock system.

The methods of fiber noise cancellation [5] may introduce an additional source of frequency noise. The limits on the stability of the phase noise cancellation system are discussed in section 3.2.1.

- Phaselock Loops

A phase lock loop will be used to stabilize a 1 W, 1064 nm laser at the end station to the light transmitted through the fiber. The phase lock loop can be designed to introduce minimal phase noise into the system [8].

- Frequency Doubling

There is an additional amount of frequency noise that may be caused by the process of frequency doubling the laser to 532 nm prior to injecting into the ETMs. The amount of noise is as yet unknown; a system similar to the Mach Zehnder interferometer used to detect fiber noise is currently being implemented to measure the frequency noise introduced by this process.

3 Fiber Stabilization

As sending stabilized light via optical fiber to the end stations over a distance of 4 km greatly increases the amount of phase noise, it is necessary to employ noise canceling techniques [5]. The measurements of phase noise introduced by the fiber and noise cancellation methods are described below.

3.1 Measuring Fiber Noise

3.1.1 Experimental Setup

A Mach Zehnder interferometer is used to measure the amount of the phase noise added by the fiber by detecting the phase difference between light traveling a short distance in free space versus through a 50 m fiber. In the present system, the beam of an 1064 nm INNOLIGHT NPRO laser¹ is incident on a 50/50 beamsplitter and is recombined using a second 50/50 beam splitter after one beam passes through a 50m fiber. The two output interference signals between the two beams are measured with two PDA255 photodiodes² (Figure 4).

The measured outputs of the two channels are given by (A.1):

$$V_1 = A(1 + \cos \theta) \tag{5}$$

¹http://www.innolight.de/pdfs/mephisto_2007.pdf, 1064 nm, 0.5 W

²http://www.thorlabs.com/newgrouppage9.cfm?objectGroup_ID=4

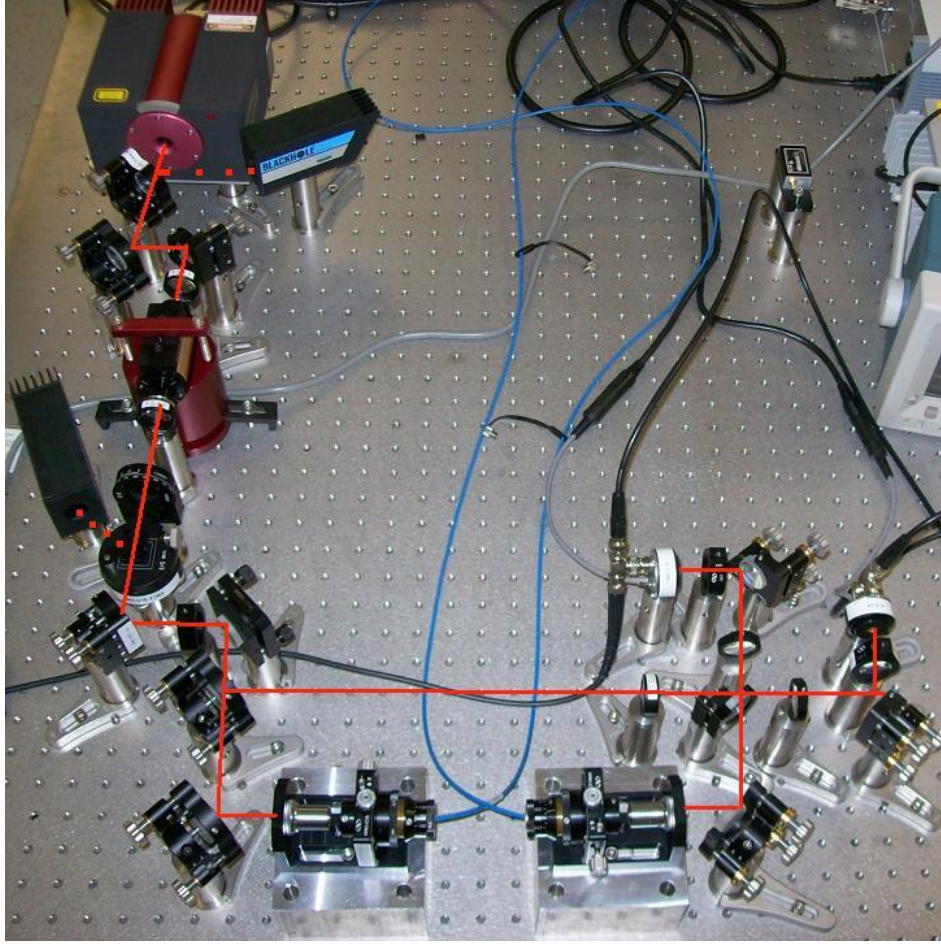

Figure 4: Fiber noise measurement setup: Mach Zehnder interferometer. The laser beam passes through a Faraday Isolation to prevent back reflection into the laser, and is incident on a 50/50 beamsplitter. Half the light passes through a MX10 lens and is coupled into the fiber. The two beams recombine in a second 50/50 beamsplitter and are focused to onto two PDA255 photodiodes, maximizing the response of the diodes to the detected signal.

$$V_2 = A(1 - \cos \theta) \quad (6)$$

where A is a constant proportional to the laser power and detector responsivity and transimpedance, and θ is the phase difference between the two arms of the interferometer. An accurate measurement of the phase θ provides a direct measure of phase noise in the system. The difference and sum of the two signals V_1 , V_2 can be digitally divided to give

$$\frac{V_1 - V_2}{V_1 + V_2} = \cos(\theta) \quad (7)$$

which is a direct measurement of phase, independent of laser amplitude.

3.1.2 Noise Sources

There are several noise sources in homodyne detection which contribute to voltage fluctuations in the diodes and can be interpreted as effective phase noise fluctuations, thus raising

the minimum amount of fiber phase noise detectable by the system. The main candidates for noise contributions are detailed below, and the calculated and measured spectra are presented in Figure 5.

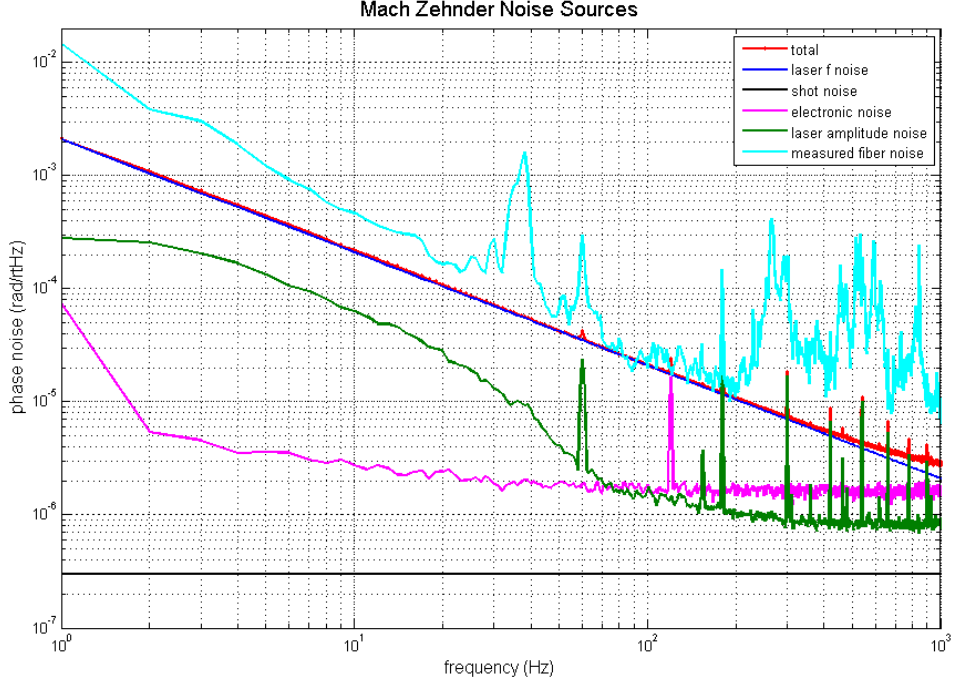

Figure 5: Equivalent phase noise in one Mach Zehnder channel. The laser frequency spectrum for a path length difference of 50 m and an assumed $1/f$ laser f noise profile, which is likely an overestimate [9]. Electronics noise is detector dark noise, measured by blocking the laser. Relative laser amplitude noise was measured by blocking the fiber arm to leave out interference effects, divided by total DC voltage. Shot noise is a negligible noise source; the total predicted noise limit is shown in red and dominated by laser f noise. The interference signal is shown as fiber noise, which exceeds background noise sources at most frequencies.

- **Laser amplitude noise and detector imbalance**

Due to imperfections of the beam splitters and differences between the two photodiodes, initially the DC signals and the amplitudes of phase fluctuation in the two channels are not equal, that is, $A_1 \neq A_2$, where

$$V_1 = A_1(1 + \cos \theta) \quad (8)$$

$$V_2 = A_2(1 - \cos \theta) \quad (9)$$

However, if the outputs are balanced such that $A_1 = A_2 = A$, the amplitude and phase noise signals can be decoupled, as in (7).

If the detectors are not properly balanced, additional noise is introduced into the measurement. For a total detected power of $A_{tot} = A_1 + A_2$ and an imbalance in the

detected power of $\delta A = A_1 - A_2$, then (7) becomes

$$\frac{V_1 - V_2}{V_1 + V_2} = \frac{\delta A + A_{tot} \cos(\theta)}{\delta A \cos(\theta) + A_{tot}} \quad (10)$$

$$\approx \cos(\theta) + \frac{\delta A}{A_{tot}}(1 - \cos^2(\theta)) \quad (11)$$

to first order in $\frac{\delta A}{A_{tot}}$. Thus the detectors must be balanced well enough such that $\frac{\delta A}{A_{tot}}$ is lower in magnitude than the other noise sources in the system (Figure 5). This method will cancel the contribution of laser intensity noise as well as noise due to the fluctuation of beam position at the laser to fiber coupling, which results in intensity fluctuations in light transmitted through the fiber.

To balance the two outputs, the gain on one of the detectors was reduced by inserting a potentiometer in series with the output of one of the detectors. This adjustable gain in one of the detectors can vary the output from 100% to 0.1%. Thus, by adjusting the gain, the detectors can be balanced. This method was found to be imprecise, since the potentiometer was not sufficiently precise or repeatable, and it was difficult to judge how well balanced the signals were. Instead, the signals were balanced digitally after being recorded, by rescaling one of the signals such that the amplitudes of fluctuation of the signals, A_1 and A_2 , were equal.

The precision of balancing is approximately 1% due to amplitude measurement error, so the contribution of laser noise is shown in Figure 5 with a relative power $\frac{\delta A}{A_{tot}} = .01$.

- **Laser frequency noise**

As the path lengths of the arms of the Mach Zehnder differ by the length of the fiber, fluctuations in the laser frequency are no longer common mode and thus are not cancelled in the detection. The equivalent length noise due to a relative laser frequency noise spectrum of $\frac{\nu(f)}{\nu}$ is given by [10]:

$$l_{freq}(f) = \Delta L \frac{\nu(f)}{\nu} \quad (12)$$

where ΔL is the path length difference between the arms. This gives an equivalent phase noise of

$$\theta_{freq}(f) = \Delta L \frac{\nu(f)}{\nu} \cdot \frac{\pi}{\lambda} \quad (13)$$

The difference in path length is assumed to be equal to the fiber length, $\Delta L = 50$ m. The frequency noise spectrum of the laser has not been directly measured, so a typical spectrum of $\nu(f) \propto 1/f$, with $\nu(100\text{Hz}) = 100 \frac{\text{Hz}}{\sqrt{\text{Hz}}}$ is assumed for concreteness.

- **Shot noise**

Shot noise in the photodiodes is given by

$$V_{shot}(f) = Z \sqrt{2eRP_{laser}} \quad (14)$$

where P is the incident laser power, e is the charge of the electron, and Z and R are the diode's transimpedance and responsivity, respectively [10]. At the operating laser power, a π shift in phase corresponds to a voltage difference of 0.66 V, so the equivalent phase noise is (Figure 5):

$$\theta_{shot}(f) = Z\sqrt{2eRP_{laser}} \cdot \frac{\pi}{0.66V} \quad (15)$$

- **Photodetector and electronics noise**

The noise of the photodiodes themselves was measured directly by blocking the incident light and measuring the spectrum of one of the channels (Figure 5). The noise level of $< 2 \times 10^{-6}$ radians/ $\sqrt{\text{Hz}}$ above a frequency of 20 Hz is consistent with the detector specifications of a noise equivalent power of $\text{NEP} = 3 \times 10^{-11} \text{W}/\sqrt{\text{Hz}}$, which translates to a noise floor of $2.9 \times 10^{-7} \text{V}/\sqrt{\text{Hz}}$ or 1.4×10^{-6} radians/ $\sqrt{\text{Hz}}$. The peak at 120 Hz is from power line pickup.

- **Environmental noise** The vibrational modes of the initial mounts for the optical elements of the Mach Zehnder were thought to contribute to the environmental noise. Rigid aluminum mounts with fewer degrees of freedom were designed and made for the fiber couplers, as the parts of the system most sensitive to noise.

- **Mode matching** To increase the amount of transmission through the fiber, laser light should be coupled into the fiber with maximal overlap between the beam and the fiber modes. Also, to maximize the interference signal between the two arms of the Mach Zehnder, the output of the fiber must be modematched with the beam propagating through free space. Gaussian beam propagation calculations will be used to optimize the placement of optical elements for this purpose, and several lenses to alter the beam parameters were added to the setup as necessary.

- **ADC noise**

As the cancellation of fiber noise requires a control and feedback system, a digital data acquisition and control system will be used for feedback and signal readout. The conversion to a digital signal will be performed using a 16 bit analog to digital converter. This process introduces noise due to the finite full scale range and bin size of the ADC. In order to reduce the effect of ADC noise, an electronic filter was designed and built. The whitening filter was designed to match the dynamic range of the signal to the range of the ADC, minimizing ADC noise. The transfer function of the filter taken using a swept sine measurement is shown in Figure 6(a). The corner frequencies are 34 Hz and 413 Hz. The effect of the filter is to whiten the spectra of the Mach Zehnder channels before input into the ADC (Figure 6(b)). The spectra are subsequently amplified to maximize the resolution and input in a low pass anti aliasing filter prior to input into the ADC.

- **Other noise sources**

Other noise sources present in homodyne detection systems may include beam jitter noise, scattered light, and temperature noise of the photodiode [11]. The temperature

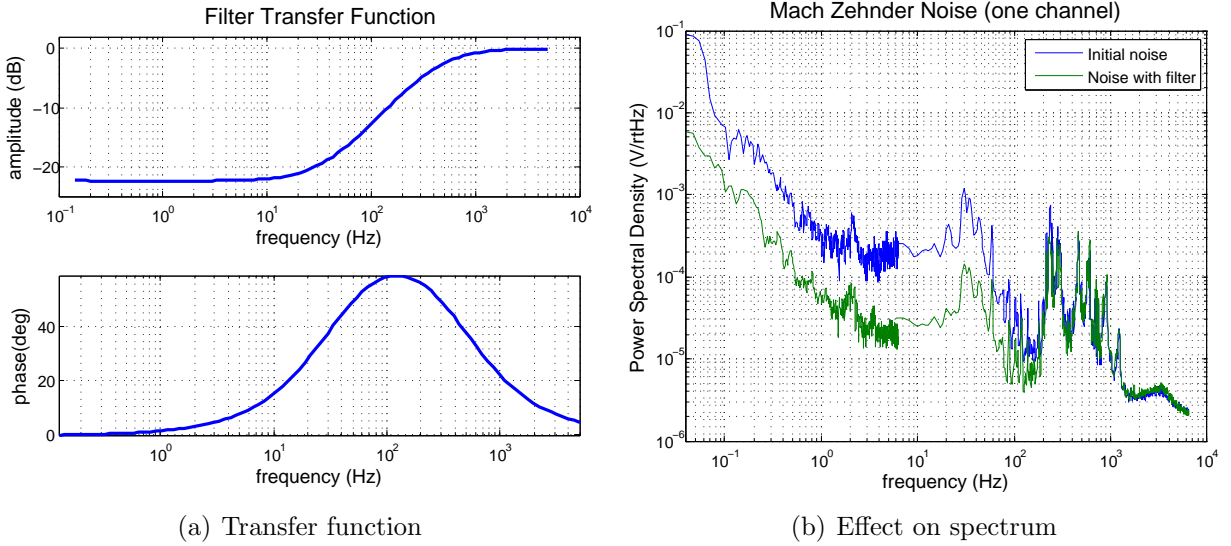

Figure 6: High pass filters will be used to whiten the output spectra prior to input into the ADC. The swept sine response of the filter is shown in (a). A typical MZ spectrum taken from one channel with and without the filter (b).

noise results from the temperature dependence of the quantum efficiency of the photodiodes. Due to this, temperature fluctuations can cause current fluctuations [11]. The exact contribution of these sources to the noise budget is unknown, but is thought to be small compared to the dominant sources listed above.

3.1.3 Fiber noise measurements

The signal from the Mach Zehnder channel is high enough above the noise sources (Figure 5) to make a confident measurement of the frequency noise introduced by the 50m fiber. The phase noise spectrum $\theta(f)$ can be converted to a frequency noise spectrum $\nu(f)$ by

$$\nu(f) = 2\pi f \cdot \theta(f) \quad (16)$$

The measured phase noise is converted into frequency (Figure 7). It is compared to a similar setup, without the fiber in one arm. This spectrum, taken for balanced path lengths, has insignificant laser frequency noise levels. The main sources of noise in the balanced path length system are thought to arise in large part from phase fluctuations due to environmental (seismic, acoustic, etc.) noise. The total rms frequency noise for the fiber spectrum is 30 Hz, as compared to 7 Hz rms for the equal arm MZ, so the fiber signal is well above the environmental noise level.

The phase noise induced in the fiber by environmental perturbations is approximated as linear [5], so the noise scales linearly with fiber length. Depending on the environmental conditions, this would result in a frequency noise of up to 2.4 kHz rms for a 4 km long fiber to be used in Advanced LIGO. This far exceeds the noise limit of 50 Hz for effective

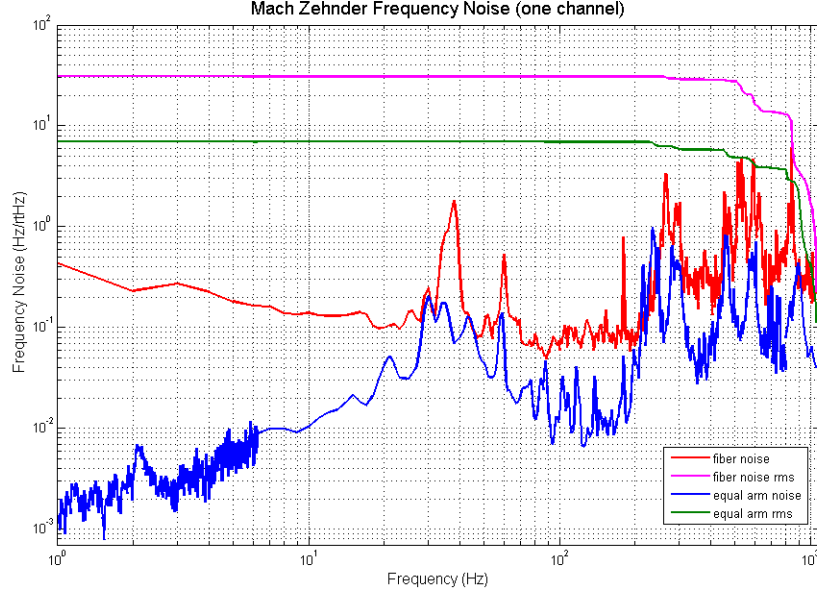

Figure 7: Frequency noise in a Mach Zehnder interferometer with equal arms (no laser frequency noise contribution), compared to the noise caused by adding a 50m fiber in one arm. The total rms noise values are 7 Hz and 30 Hz, respectively.

lock acquisition presented in the previous section, necessitating the implementation of fiber induced phase noise cancellation techniques.

3.2 Canceling Fiber Noise

In order to retrieve a stable frequency at the end stations after the PSL light is transferred via fiber, the noise induced by the fiber must be detected and cancelled. In order to detect the amount of phase noise, a small fraction of the light from the end stations is reflected back through the fiber and compared to the initial input light. Two assumptions about the acoustic noise, resulting in phase noise, are made: first, that the noise is linear, and second, that the acoustic noise on time scales longer than 1 ms is stationary on time scales longer than the round trip of the light through the fiber. Then noise of the returned light will be double the noise of the single pass light, and the exact contribution of the fiber can be retrieved by dividing the signal by 2. The resulting signal is then filtered and fed back to the phase actuator - an AOM - with opposite sign, so the single pass fiber noise is precisely cancelled.

A proposed setup for this scheme is shown in Figure 8 and described below.

A pickoff from the PSL at initial frequency f_0 is split in a polarizing beamsplitter; the transmitted light passes through AOM 1 driven at frequency f_1 and modulated at a correction frequency f_c . The -1 order beam is selected and injected into the fiber. By traveling through the fiber, fiber noise f_n is added to give an output frequency of $f_0 - f_1 + (f_n - f_c)$. If the correction frequency is precisely equal to the fiber noise, the fiber contribution is cancelled

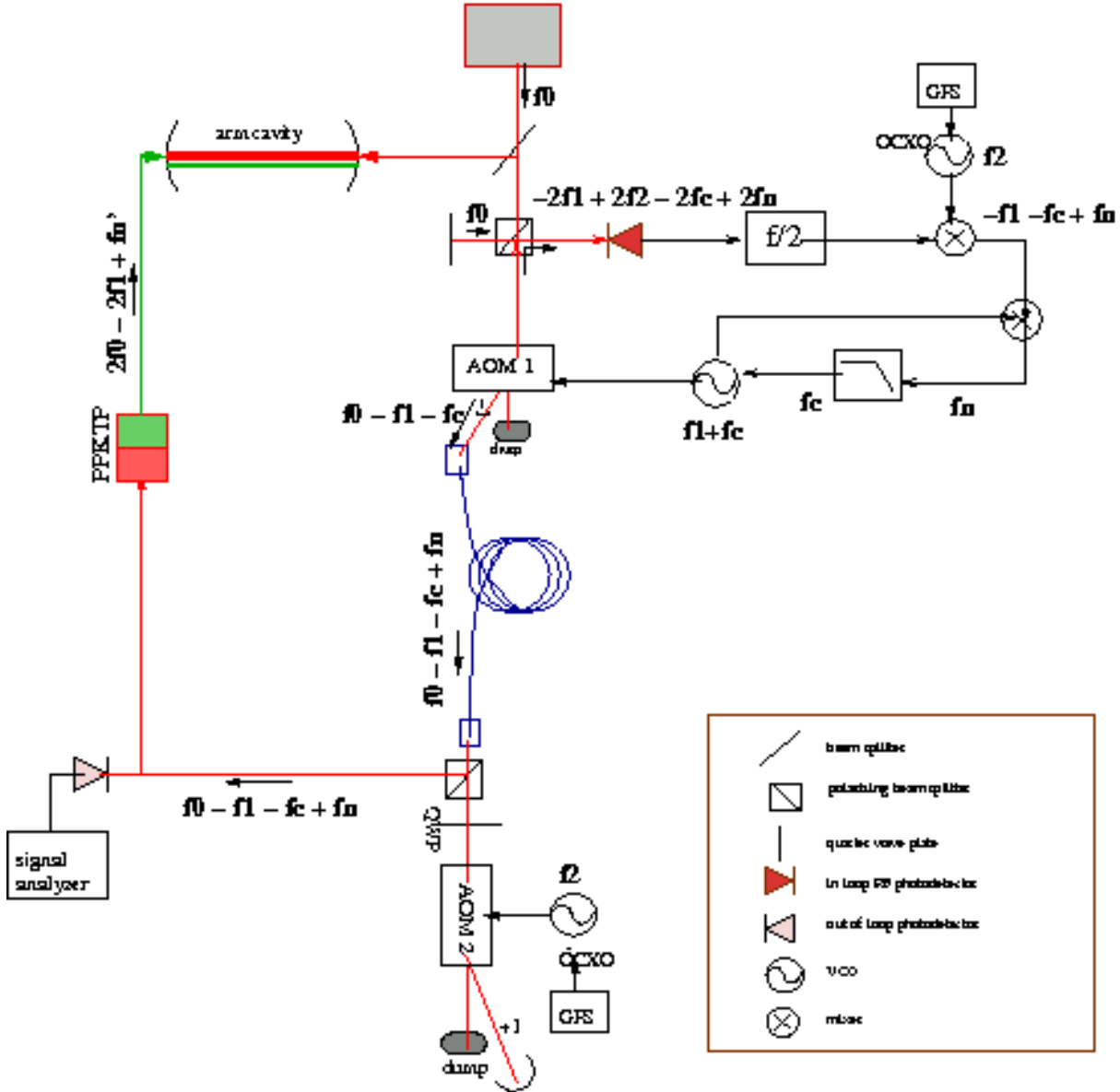

Figure 8: Auxiliary Lock System

and the output is a narrow bandwidth beam.

Part of the output light double passes AOM 2 driven at a frequency f_2 and is injected again into the fiber and passes AOM 1 for a total frequency of $f_0 + 2f_2 - 2f_1 - 2f_c + 2f_n$. The light is beat with the original laser light and detected with a fast photodetector. The signal's frequency is divided by two with a wenzel $f/2$ box³ and demodulated at frequencies f_2 and $f_1 + f_c$. This result in a signal f_n directly corresponding to the fiber noise, which is low passed with a corner frequency of 1 kHz. The resulting signal is used to modulate AOM 1.

³<http://www.wenzel.com/pdffiles1/Dividers/LNFDN.pdf>

3.2.1 Noise sources in the system

- AOM1 In the current setup, the center frequency shift f_1 from the first AOM is not cancelled and is present in the laser light output from the fiber. Thus this frequency needs to be stable enough to not add extra noise.
- Beam jitter
Modulation of the drive frequency of the first AOM will shift the position of the beam. From 40 m experience, shifting the drive frequency of a 160 MHz AOM by 1 MHz can shift the beam up to one beam diameter. However, the expected amount of frequency noise due to a 4 km fiber should not exceed 2.4 kHz according to my estimate or 2 kHz in the Jun Ye paper for 6.9 km. Thus the fractional change in the drive frequency is minimal and should not affect the position of the beam and is not a significant noise source.
- AOM2 We will use a GPS synchronized OCXO (oven-controlled crystal oscillator) for a stable voltage source. On short time scales, the crystal has very low noise: at 10 Hz, the phase noise is up to -120 dBc/Hz; it goes down to the phase noise floor of -165 dBc/Hz by 1 kHz. On longer time scales, the crystal can drift - the aging of the crystal ($< 1 \times 10^{-9}$ per day) and temperature fluctuations contribute to drift (1.5×10^{-8} per $^{\circ}\text{C}$). The GPS will be used to correct for long term drift. The difference df_2 between the drive frequency of AOM 2 and the frequency used to demodulate the signal will be directly present in the output of the fiber.
- Electronics The Wenzel frequency divider has a very low phase noise floors of -165 dBc/Hz, which will not contribute to the overall noise.

3.2.2 Experimental Setup

As a first step in testing the proposed cancellation method, a simplified setup was implemented (Figure 9). A beam is incident on a 50/50 beamsplitter; the transmitted light passes through a fiber and Crystal Technology AOM⁴ driven at 200 MHz. The -1 order beam is beat with the original light and detected with a New Focus 1611 1 GHz photodetector⁵. The signal is then demodulated and filtered and fed back to the AOM. The layout of the electronics is shown in Figure 10.

The AOM is driven at 200 MHz by a Marconi 2023B⁶ signal generator, amplified using Mini-Circuits Power Amplifier ZHL-1A⁷. The Marconi 2023B is frequency locked to a Fluke RF signal generator.

The beat signal between the original light and the light passed through the fiber and AOM is detected in two fast photodiodes, New Focus 1811⁸ (out of loop) and 1611 (in loop). The

⁴<http://www.crystaltechnology.com/docs/97-02029-05rA.pdf>

⁵<http://www.newfocus.com/products/?navid=3&theView=modelDetail&productLineId=3&productGroupId=137&modelGroupId=1055&modelRangeId=1055&modelId=1351>

⁶<http://www.testequity.com/products/323/>

⁷<http://www.minicircuits.com/pdfs/ZHL-1A.pdf>

⁸<http://www.newfocus.com/products/?navid=3&theView=modelDetail&productLineId=3&productGroupId=137&modelGroupId=1054&modelRangeId=1054&modelId=1377>

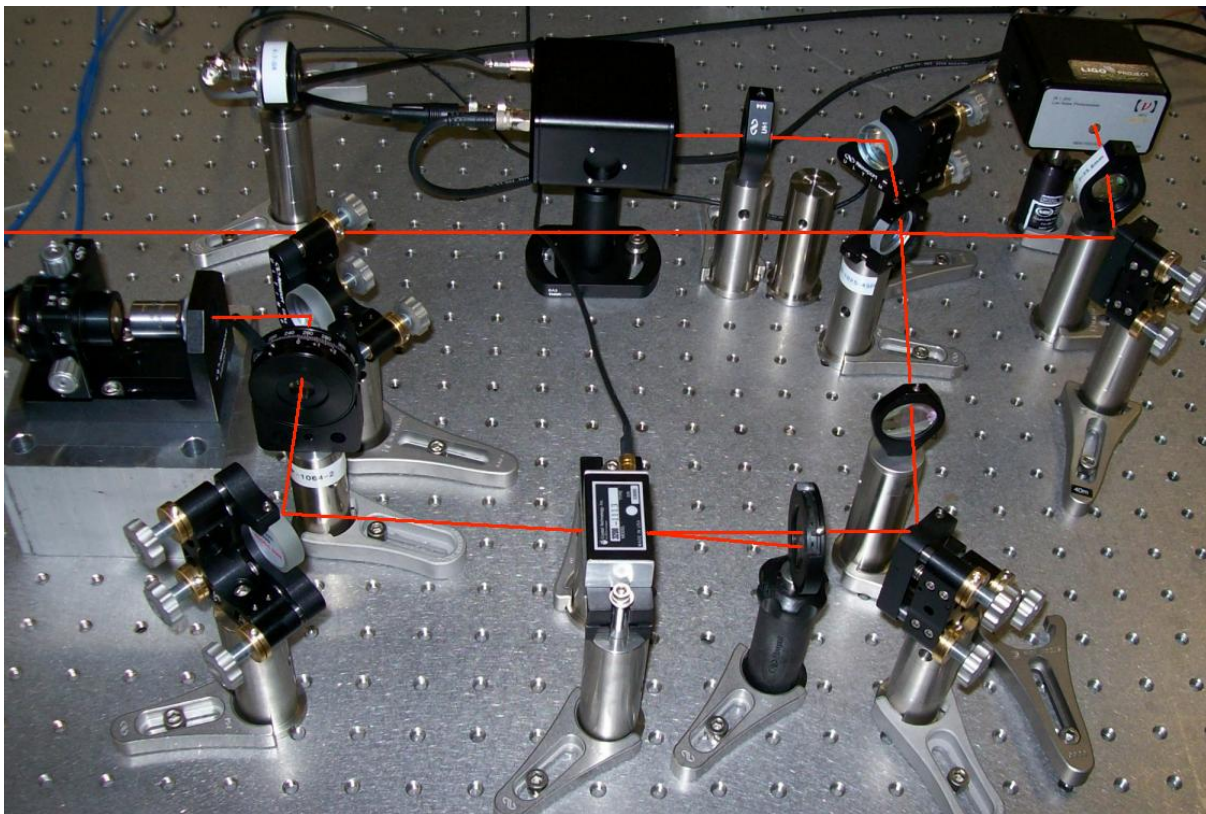

Figure 9: Single-pass fiber stabilization

signal from each detector is mixed with the 200 MHz signal and lowpassed to retrieve a signal about DC. These are both input into the DAQ and recorded. The demodulated signal from 1611 is also amplified with an SR 560 preamplifier⁹ and used to modulate the AOM drive frequency. At high loop gain, the fluctuation in the AOM frequency cancels the noise picked up from traveling through the fiber.

The in and out of loop spectra were measured for open and closed loop at a gain of 1 kHz (Figure 11).

4 Future Work

The future goals of the project are as follows:

- **Further test fiber noise cancellation scheme** While the initial experiment of the noise cancellation is promising, further tests where the light double passes the fiber and is detected at the input must be implemented to make this method practical.

⁹<http://www.thinksrs.com/products/SR560.htm>

SR560 #1: DC coupled, 10kHz LP, -12dB per octave slope, gain = 2000x
 SR560 #2: DC coupled, 10kHz LP, -12dB per octave slope, gain = 2000x
 SR560 #3: 100kHz LP, -6dB per octave slope, gain = 1000x

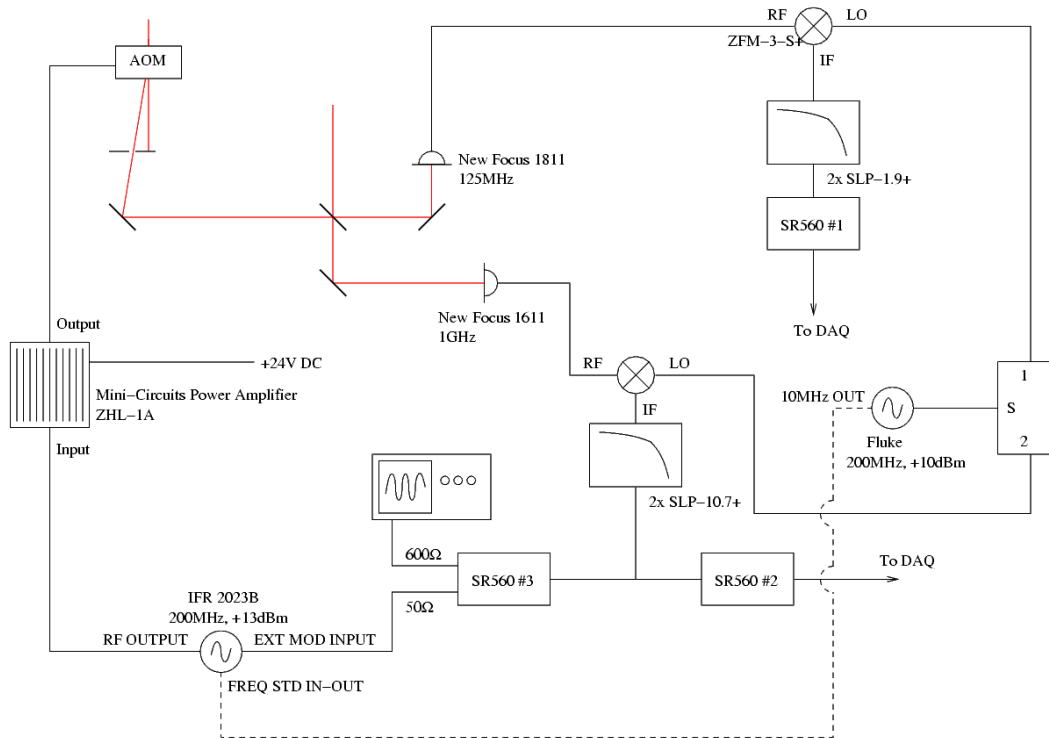

Figure 10: Single-pass fiber stabilization: electronics layout

- **Frequency doubling** It is not known how much noise a frequency doubling scheme will introduce. The noise from this process is being measured, and must be reduced if it is found to be above the goal of 50 Hz rms.
- **Trial of PDH locking method at 40m** If after the above tests the scheme is found to be viable, the PDH lock can be implemented on the arms of the 40m and incorporate into the digital control system.
- **Extend technique to other degrees of freedom** If the frequency doubled PDH auxiliary lock is found to be helpful in the locking process of the arms, it could be extended to the remaining three degrees of freedom of the interferometer to further expedite the locking process. Of special interest is the SRCL degree of freedom (Figure 1), or the signal recycling cavity. Tuning the offset of the signal recycling cavity can shift the range of the band where the detector is most sensitive to gravitational waves. The offset could be controlled with the same technique using green light injected into SRM.

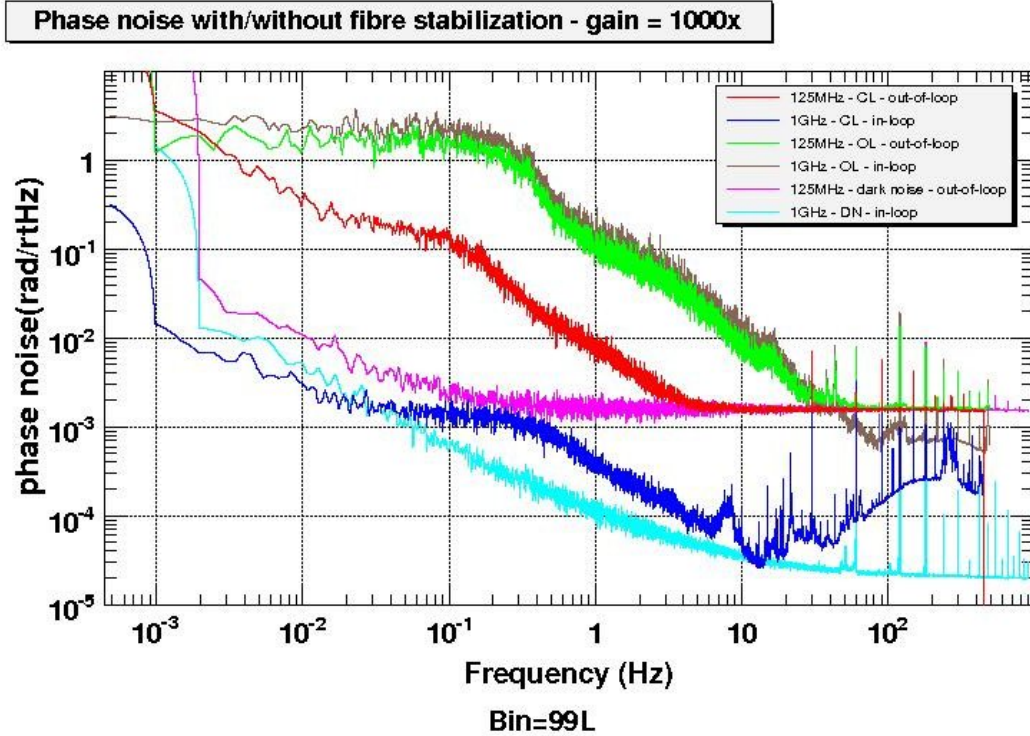

Figure 11: Single-pass fiber stabilization: in and out of loop measurements. The amount of noise in the output light is significantly reduced at high loop gains.

5 Summary and Conclusion

The main noise source in the proposed frequency doubled PDH scheme, fiber phase noise, was measured using a Mach Zehnder interferometer and analyzed. The amount of noise extrapolated to a 4 km fiber was found to exceed the set goal of 50 Hz at low frequencies.

A fiber phase noise cancellation scheme was proposed. An initial test of the noise cancellation setup was implemented, in which the noise was measured directly and cancelled at the output of the fiber. The amount of noise in a closed feedback loop decreased by an order of magnitude for frequencies from 10 mHz to 10 Hz relative to the open loop measurement.

The next step is to implement a more true to life cancellation scheme with lower noise electronics and optics. It is also important to test the other potential noise source in the auxiliary lock system, the frequency doubling process. If frequency doubling and a fiber with a noise cancellation setup are found to be sufficiently low noise, the auxiliary locking scheme can be tested and implemented at the 40m interferometer.

A Methods

A.1 Derivation of Mach Zehnder output signals

If the electric field incident on the first beamsplitter is given by Figure 12.

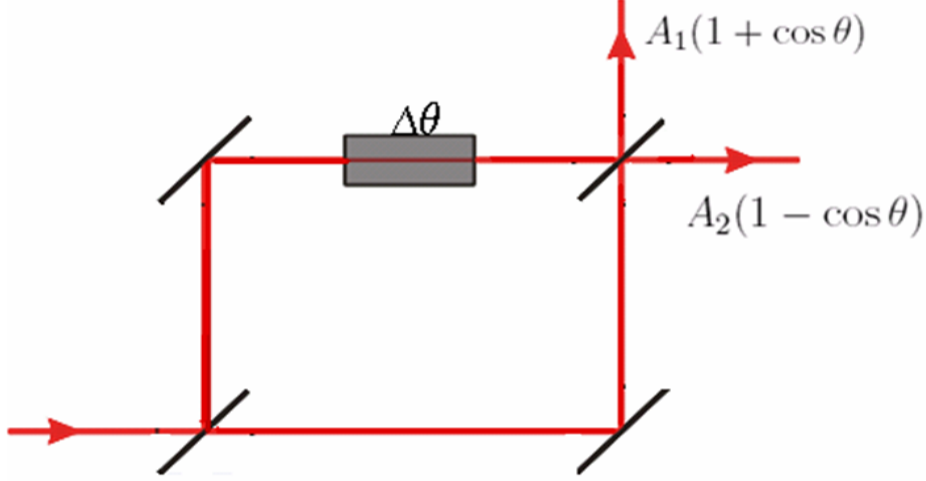

Figure 12: Model Mach Zehnder interferometer

$$E_{laser} = Ee^{i\omega t} \quad (17)$$

then assuming the free space path has zero phaseshift while the fiber path has a phaseshift of θ with respect to the free space path, then the beam is split into E_1 and E_2 :

$$E_1 = -\frac{1}{\sqrt{2}}Ee^{i\omega t}, \quad E_2 = \frac{1}{\sqrt{2}}Ee^{i\omega t} \quad (18)$$

After the beam passes through the fiber, it gains a relative phase θ ,

$$E_3 = -\frac{1}{\sqrt{2}}Ee^{i(\omega t + \theta)} \quad (19)$$

The fields E_2 and E_3 recombine at the second beamsplitter to give two interfering fields E_A and E_B incident on the photodetector.

$$E_A = \frac{1}{\sqrt{2}}(E_2 - E_3), \quad E_B = \frac{1}{\sqrt{2}}(E_2 + E_3) \quad (20)$$

Taking the magnitudes gives the output power

$$P_A = |E_A|^2 = \frac{1}{2}E^2(1 + \cos(\theta)) \quad P_B = |E_B|^2 = \frac{1}{2}E^2(1 - \cos(\theta)) \quad (21)$$

B LIGO Acronyms

ADC	Analog to Digital Converter
AOM	Acousto-optic modulator
DOF	Degree of freedom
ETMX(Y)	End Test Mass on the X(Y) arm
GPS	Global Positioning System
ITMX(Y)	Input Test Mass on the X(Y) arm
LIGO	Laser Interferometer Gravitational-Wave Observatory
LO	Local Oscillator
OCCO	Over-controlled crystal oscillator
PDH	Pound Drever Hall Locking
PLL	Phase Lock Loop
PPKTP	Periodically poled potassium titanyl phosphate
PSL	Prestabilized Laser
RF	Radio Frequency
VCO	Voltage-controlled oscillator

References

- [1] M. Evans, N. Mavalvala, P. Fritschel, R. Bork, B. Bhawal, R. Gustafson, W. Kells, M. Landry, D. Sigg, R. Weiss, S. Whitcomb, and H. Yamamoto. *Optics Letters*, 27:598, 2002.
- [2] R. Adhikari, Y.Aso, S.Ballmer, R. Bork, J. Miller, S.Vass, R.Ward, and A. Weinstein. Upgrade of the 40m interferometer. 2008.
- [3] Bram Slagmolen, Glenn de Vine, David Rabeling, and et. al. Advanced ligo arm cavity pre-lock acquisition system. 2008.
- [4] Eric Black. Notes on the Pound-Drever-Hall technique. 1998.
- [5] Long-Sheng Ma, Peter Jungner, Jun Ye, and John L. Hall. *Optics Letters*, 19:1777, 1994.
- [6] Dichroic coatings, 2008. Advanced LIGO Wiki, http://lhocds.ligo-wa.caltech.edu:8000/advligo/Dichroic_Coatings.
- [7] LIGO Scientific Collaboration and ed. P. Fritschel. Advanced ligo systems design. 2001. T010075-00-D.
- [8] F. M. Gardner. *Phase Lock Techniques*. Wiley, New York, 1967.
- [9] Rana Adhikari. Sensitivity and noise analysis of 4km laser interferometric gravitational wave antennae. 2004.
- [10] Peter R. Saulson. *Fundamentals of Interferometric Gravitational Wave Detectors*. World Scientific Publishing Co., 1994.
- [11] Kirk McKenzie. Squeezing in the audio gravitational wave detection band. 2002.