

LASER INTERFEROMETER GRAVITATIONAL WAVE OBSERVATORY
- LIGO -
CALIFORNIA INSTITUTE OF TECHNOLOGY
MASSACHUSETTS INSTITUTE OF TECHNOLOGY

LIGO- - -

Date: 2008/09/08

Fiber Noise Cancellation scheme

Masha Baryakhtar, John Miller, Aidan Brooks, Rana Adhikari

California Institute of Technology
LIGO Project, MS 18-34
Pasadena, CA 91125
Phone (626) 395-2129
Fax (626) 304-9834
E-mail: info@ligo.caltech.edu

Massachusetts Institute of Technology
LIGO Project, Room NW22-295
Cambridge, MA 02139
Phone (617) 253-4824
Fax (617) 253-7014
E-mail: info@ligo.mit.edu

LIGO Hanford Observatory
Route 10, Mile Marker 2
Richland, WA 99352
Phone (509) 372-8106
Fax (509) 372-8137
E-mail: info@ligo.caltech.edu

LIGO Livingston Observatory
19100 LIGO Lane
Livingston, LA 70754
Phone (225) 686-3100
Fax (225) 686-7189
E-mail: info@ligo.caltech.edu

A pickoff from the stable PSL light with frequency f_0 double passes AOM1, driven at a frequency $f_1/2$. The light then travels to the fiber, gaining some noise n . It is then frequency doubled. Assuming the feedback loop sets $f_1 = n$ and there are no additional noise sources, the output light is given by $f_0 + n'$, where n' is noise caused by the frequency doubling process (Figure 1).

A pickoff from the beam after the fiber double passes through AOM2 and is shifted by a fixed frequency f_2 . The light is reflected back into the fiber, again adding noise n , to give a frequency of $f_0 + 2n - f_1 + 2f_2$. The signal is detected by an RF photodetector and demodulated at $2f_2$, frequency divided by 2, demodulated at $f_1/2$, and frequency divided by 2 again to give an $n/2$ signal. It is low pass filtered, and the resulting signal drives the VCO for AOM1 to compensate for the fiber noise n at low frequencies.

how the GPS will help.

The noise df_2 introduced by AOM2 will be directly present in the outout of the fiber (Figure 2).

- Electronics
 - RF frequency doubler and divider have phase noise floors of -178 dBc/Hz and -165 dBc/Hz, respectively.
- Phase matching - the signals that are being demodulated have to have the same phase.

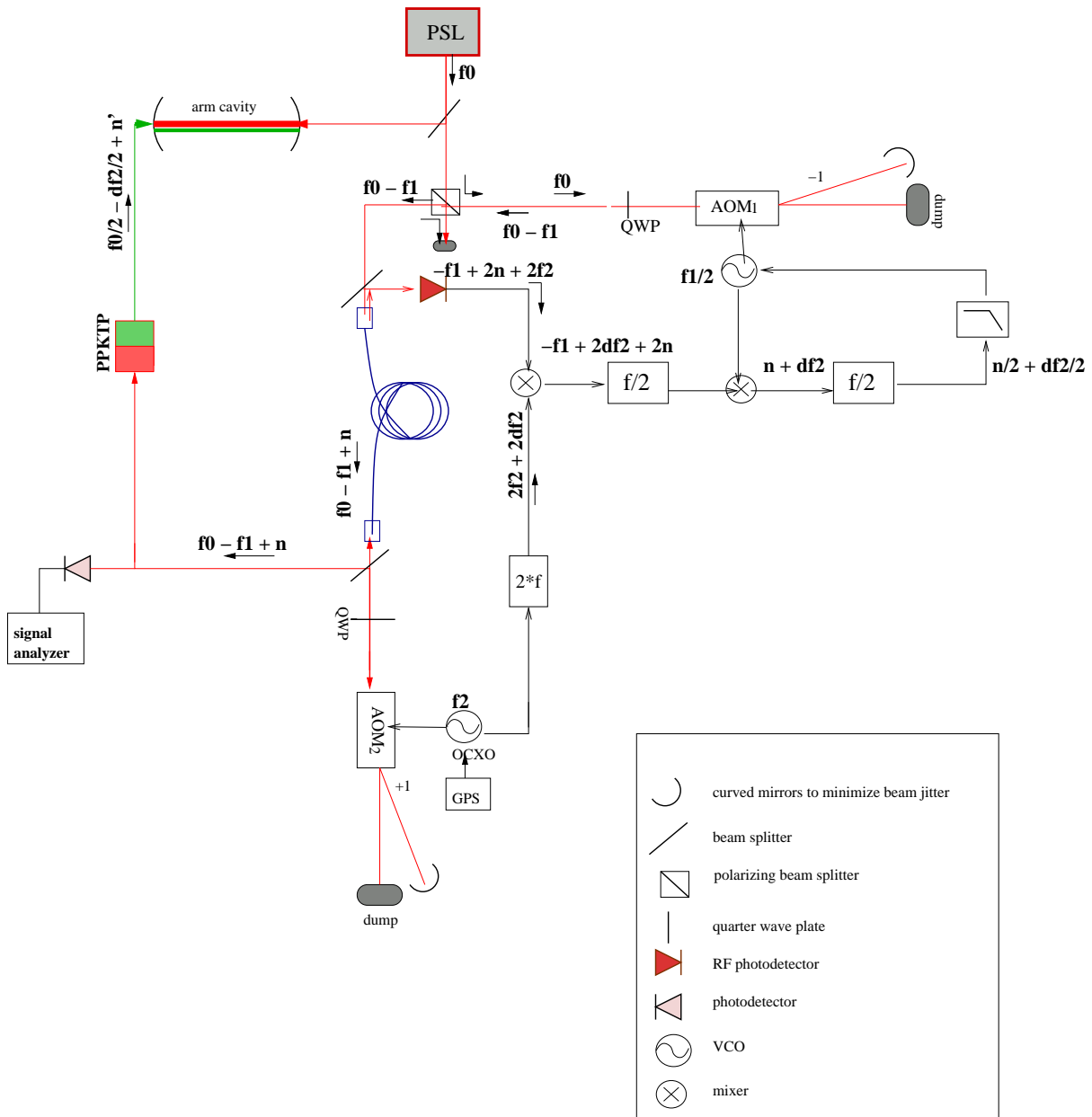

Figure 2: Auxiliary Lock System with a bit of noise