

LASER INTERFEROMETER GRAVITATIONAL WAVE OBSERVATORY  
- LIGO -  
CALIFORNIA INSTITUTE OF TECHNOLOGY  
MASSACHUSETTS INSTITUTE OF TECHNOLOGY

LIGO- - -

Date: 2008/08/08

## Fiber Noise Cancellation scheme

Masha Baryakhtar, John Miller, Aidan Brooks, Rana Adhikari

**California Institute of Technology**  
**LIGO Project, MS 18-34**  
**Pasadena, CA 91125**  
Phone (626) 395-2129  
Fax (626) 304-9834  
E-mail: info@ligo.caltech.edu

**Massachusetts Institute of Technology**  
**LIGO Project, Room NW22-295**  
**Cambridge, MA 02139**  
Phone (617) 253-4824  
Fax (617) 253-7014  
E-mail: info@ligo.mit.edu

**LIGO Hanford Observatory**  
**Route 10, Mile Marker 2**  
**Richland, WA 99352**  
Phone (509) 372-8106  
Fax (509) 372-8137  
E-mail: info@ligo.caltech.edu

**LIGO Livingston Observatory**  
**19100 LIGO Lane**  
**Livingston, LA 70754**  
Phone (225) 686-3100  
Fax (225) 686-7189  
E-mail: info@ligo.caltech.edu

A pickoff from the stable PSL light with frequency  $f_0$  double passes AOM1, driven at a frequency  $f_1/2$ . The light then travels to the fiber, gaining some noise  $n$ . It is then frequency doubled. Assuming the feedback loop sets  $f_1 = n$  and there are no additional noise sources, the output light is given by  $f_0 + n'$ , where  $n'$  is noise caused by the frequency doubling process (Figure 1).

A pickoff from the beam after the fiber double passes through AOM2 and is shifted by a fixed frequency  $f_2$ . The light is reflected back into the fiber, again adding noise  $n$ , to give a frequency of  $f_0 + 2n - f_1 + 2f_2$ . The signal is detected by an RF photodetector and demodulated at  $2f_2$ , frequency divided by 2, demodulated at  $f_1/2$ , and frequency divided by 2 again to give an  $n/2$  signal. It is low pass filtered, and the resulting signal drives the VCO for AOM1 to compensate for the fiber noise  $n$  at low frequencies.

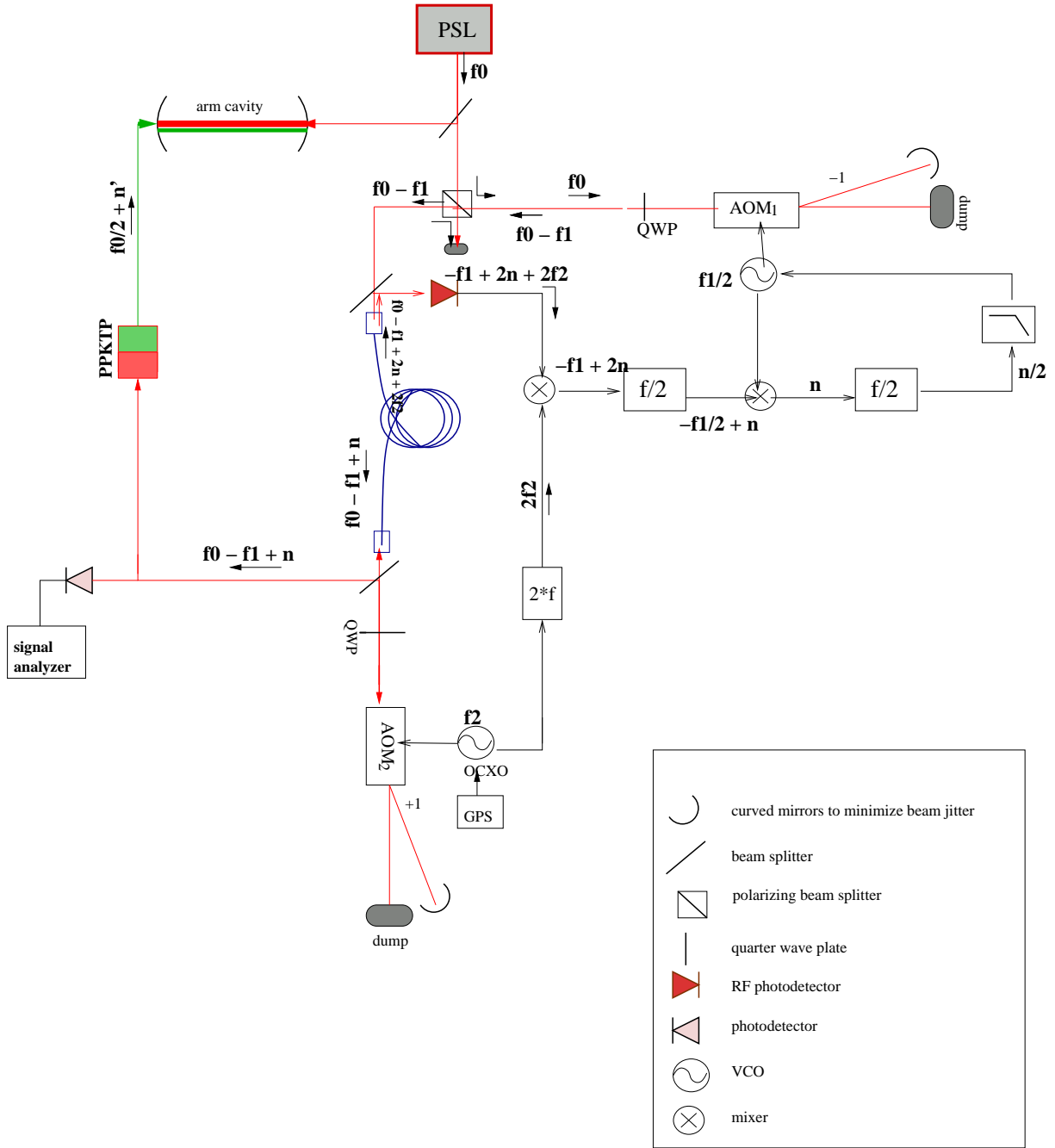

Figure 1: Auxiliary Lock System

Noise sources in the system:

- AOM2 As the AOM2 will be 4 km away from where the light is being demodulated, the noise of the VCO can't be cancelled perfectly. The noise  $df_2$  introduced by AOM2 will be directly present in the outout of the fiber (Figure 2). We will use a GPS synchronized OCXO (oven-controlled crystal oscillator) for a stable voltage source.
- Electronics

- RF frequency doubler
- Wenzel  $f/2$  boxes
- Phase matching - the signals that are being demodulated have to have the same phase.

Random thoughts:

- AOM2 - will probably be the dominant noise source. From previous calculations, the noise should not exceed a total of 75 Hz rms below 10 kHz. Is it absolutely necessary? Is there a way to distinguish the double passed fiber light without frequency shifting, for example different polarization, or are other methods too imprecise?
- Double passing - how much noise is caused by the  $f/2$  boxes? Should compare AOM beam jitter noise to this to see if double passing  $AOM_1$  is advantageous. If we don't use double pass in that case, we will need to divide  $f$  by 2 once instead of twice.

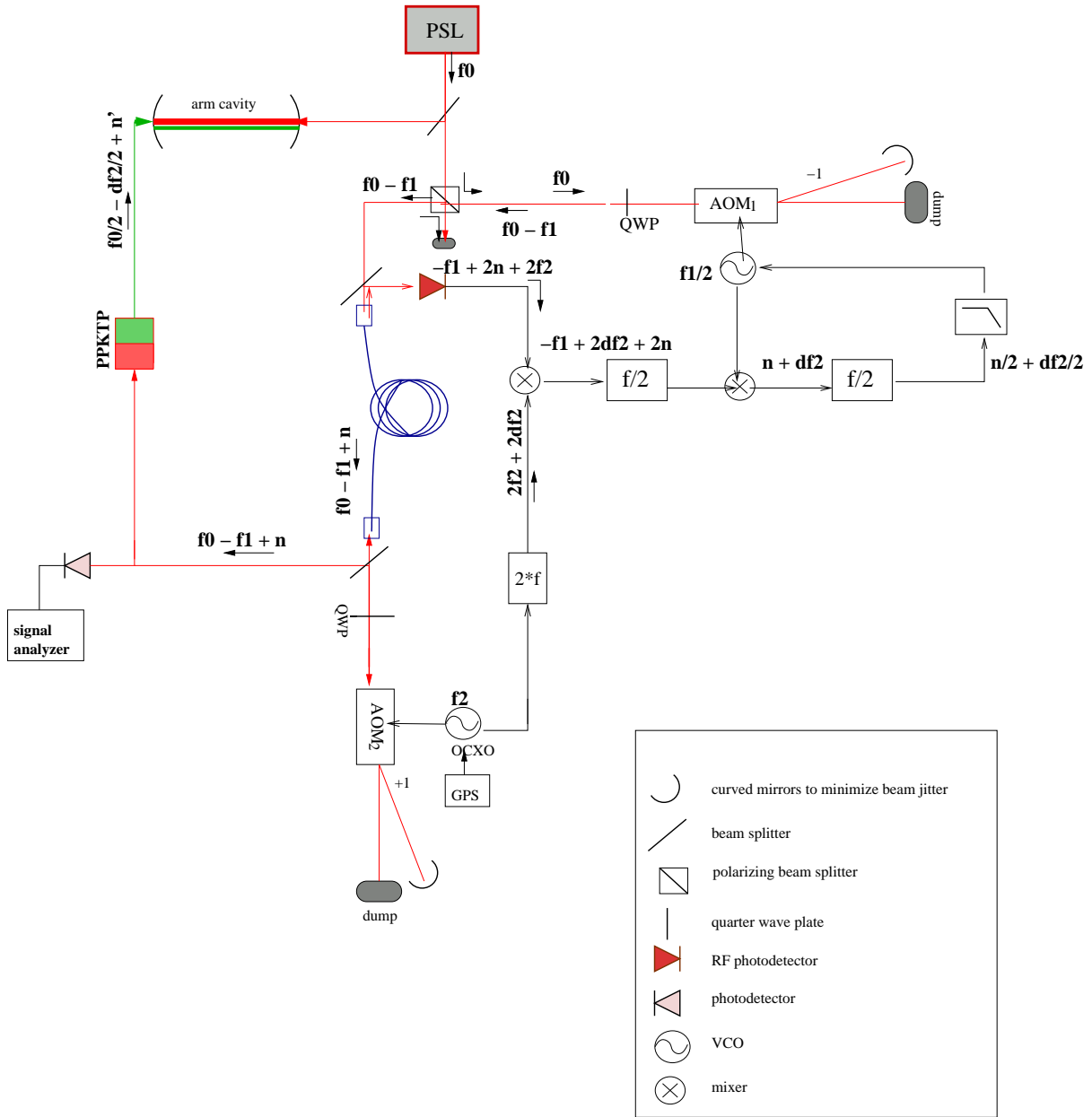

Figure 2: Auxiliary Lock System with a bit of noise