

HUMAN HEALTH

ENVIRONMENTAL HEALTH

PHOTON DETECTION FOR TOMORROW'S CUTTING-EDGE APPLICATIONS.

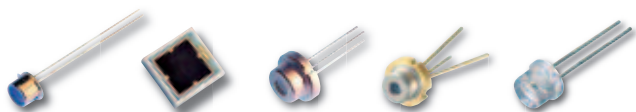

Photon Detection Solutions

For Health, Safety and Security Applications



MAKING YOUR WORLD HEALTHIER, SAFER & MORE SECURE.

At PerkinElmer, we're sensing what you need for a healthier, cleaner and safer tomorrow. From Photon Counting Modules to Silicon Detectors, InGaAs Detectors, and Pulsed Laser Diodes, our photon detection technologies are address-

ing your high-performance and high-volume applications. We have the detection technologies and capabilities to enhance and accelerate your OEM designs. You can depend on our seven world-class design, manufacturing and R&D facilities including: Montreal, Canada; Wiesbaden, Germany; Fremont, USA; Singapore; Manila, Philippines; Shenzhen, China; and Batam, Indonesia. We're sensing what you need. For The Better.

Our Photon Detection Solutions are contributing to:

Longer, Healthier Lives.

- Luminescence and fluorescence for analytical and clinical diagnostics
- Photon counting, particle sizing
- PET, CT, and MRI scanning

Enhanced Safety and Security.

- X-ray scanning of luggage, cargo and food
- Laser range finding – industrial and consumer
- Smoke detection
- Safety curtains

■ SECTION 1 • MODULES AND OPTICAL RECEIVERS

- SPCMs based on high-performing APDs – for visible and NIR single photon counting
- CPMs and modules for lowest dark noise applications
- CCD cameras – for high speed imaging
- PIN and APD hybrid receivers – for high signal detection

■ SECTION 2 • PHOTODIODE ARRAYS FOR X-RAY SECURITY SCANNING

- Photodiode solutions with scintillators for x-ray scanners

■ SECTION 3 • PHOTODIODES FOR HIGH-PERFORMANCE APPLICATIONS

- Si and InGaAs APDs and PIN photodiodes – for industrial applications and high-volume laser range finding
- Si APD arrays – for beam positioning and spectrometers
- Large-area/UV-enhanced APDs – for molecular imaging, high-energy radiation detection

■ SECTION 4 • PHOTODIODES & -TRANSISTORS FOR HIGH-VOLUME APPLICATIONS

- Smoke detection components
- Ambient light sensors
- Si-photodiodes and-transistors
- Infrared switches

■ SECTION 5 • PULSED LASER DIODES AND INFRARED LEDES (IREDS)

- High power laser diodes – for laser range finding
- Infrared emitting diodes – for smoke detection and safety curtains

SECTION 1

Modules and Optical Receivers

4

SECTION 2

Photodiode Arrays for X-Ray Security Scanning

14

SECTION 3

Photodiodes for High-Performance Applications

16

SECTION 4

Photodiodes & -Transistors for High-Volume Applications

24

SECTION 5

Pulsed Laser Diodes and Infrared LEDs (IREDs)

38

MODULES & RECEIVERS FOR ANALYTICAL & MOLECULAR APPLICATIONS



Single Photon Counting Modules – SPCM

Applications

- Particle sizing
- Confocal microscopy
- Photon correlation spectroscopy
- Quantum cryptography
- Astronomical observation
- Optical range finding
- Adaptive optics
- Ultra sensitive fluorescence

Features and Benefits

- Peak photon detection efficiency at 650 nm: 65 % typical
- Active area: 180 μm diameter
- Gated output
- Single +5V supply
- FC receptacle option for fiber coupling
- EU RoHS compliant
- Array of 4 channels available

Product Description

SPCM-AQRH is a self-contained module that detects single photons of light over the 400 nm to 1060 nm wavelength range - a range and sensitivity that often outperforms a photomultiplier tube. The SPCM-AQRH uses a unique silicon avalanche photodiode (SLiK®) with a circular active area that achieves a peak photon detection efficiency of more than 65 % at 650 nm over a 180 μm diameter. The photodiode is both thermoelectrically cooled and temperature controlled, ensuring stabilized performance despite ambient temperature changes. Circuit improvements have reduced the overall power consumption.

Count speeds exceeding 20 million counts per second (Mc/s) are achieved by the SPCM-AQRH-1X module (> 30 million counts per second on some models). There is a “dead time” of 35 ns between pulses but other values can be set at the factory.

As each photon is detected, a TTL pulse of 2.5 Volts (minimum) high into a 50 Ohm load and 15 ns wide is output at the rear BNC connector. The module is designed to give a linear performance at a case temperature between 5° C and 40° C.

The SPCM is also available in a 4 channel array format, the SPCM-AQ4C. It is a module of 4 APDs with single power supply and 4 individual outputs.

This series of photon counting modules are designed and built to be fully compliant with the European Union Directive 2002/95/EEC - Restriction of the use of certain Hazardous Substances in electrical and electronic equipment (RoHS).

Graph 1

Characteristics SPCM Series

Photon Detection Efficiency (Pd)

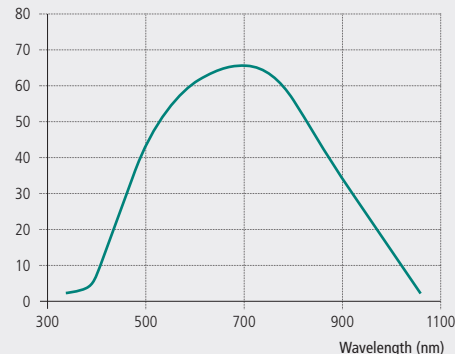

Product Table

Single Photon Counting Modules – SPCM

Part Number	Photo Sensitive Diameter	Maximum Dark Count Rate	Photon Detection Efficiency @ 700 nm	Max. Count Rate before Saturation	Dead Time	Pulse Width
Unit	mm	c/s	%	c/s	ns	ns
SPCM-AQRH-10	0.18	1500	65 %	25M	32	15
SPCM-AQRH-11	0.18	1000	65 %	25M	32	15
SPCM-AQRH-12	0.18	500	65 %	25M	32	15
SPCM-AQRH-13	0.18	250	65 %	25M	32	15
SPCM-AQRH-14	0.18	100	65 %	25M	32	15
SPCM-AQRH-15	0.18	50	65 %	25M	32	15
SPCM-AQRH-16	0.18	25	65 %	25M	32	15
SPCM-AQ4C	Fibered	500	60 %	>2M / channel	50	30
C30902SH-TC ¹	0.475	2500	>5 %	-	-	-
C30902SH-DTC ²	0.475	350	>5 %	-	-	-

1. C30902SH-TC (0° C operation), 2. C30902SH-DTC (-20° C operation)

Figure 1

Mechanical Dimensions of the SPCM-AQRH Series

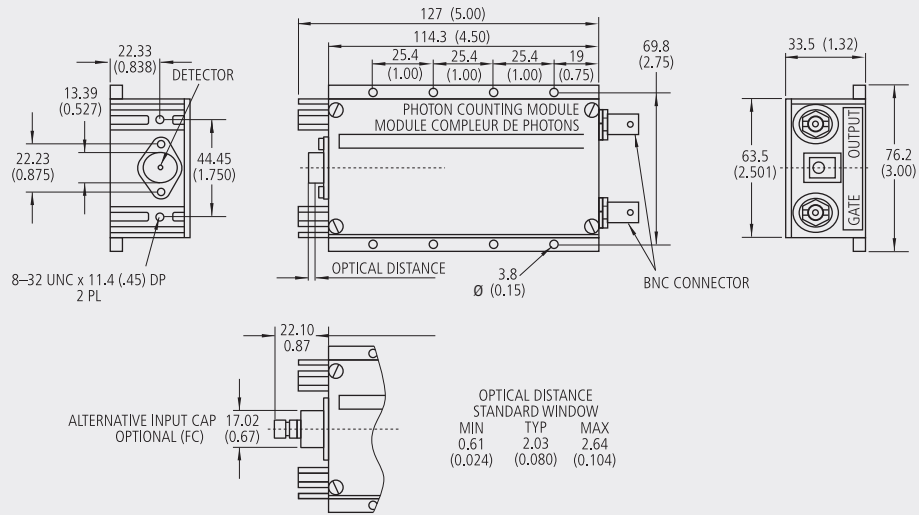

Figure 2

Mechanical Dimensions of the SPCM-AQ4C

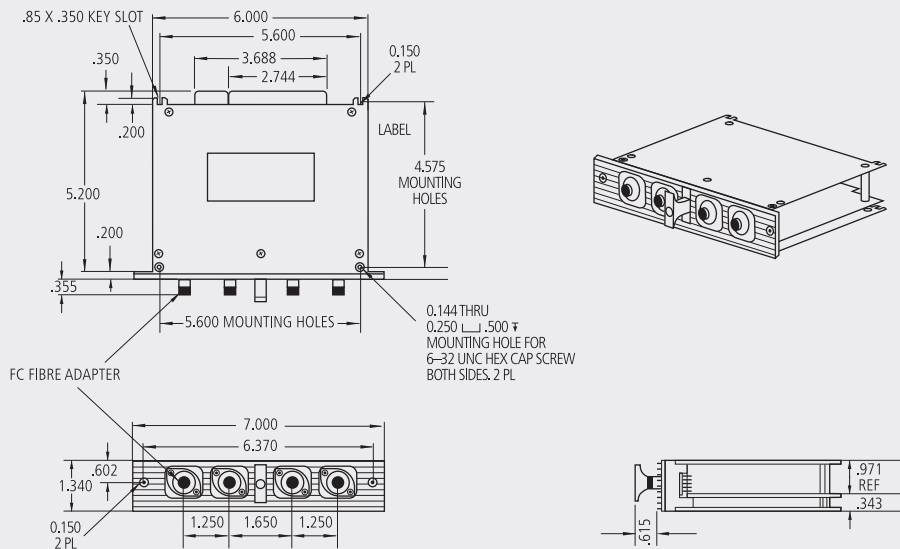
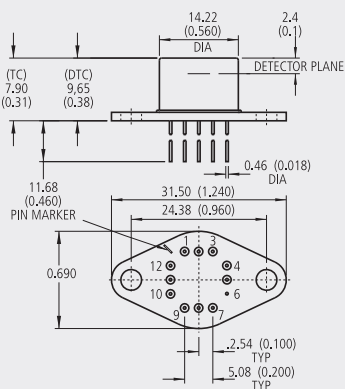

Figure 3

Package Drawing – TO-8 Flange



PHOTOMULTIPLIERS FOR MOLECULAR DETECTION IN ANALYTICAL APPLICATIONS & MEDICAL DIAGNOSTICS

MODULES AND OPTICAL RECEIVERS ■

Channel Photomultipliers
& Modules (CPM)



Channel Photomultipliers & Modules

Applications

- Photon counting
- Luminescence & fluorescence spectroscopy
- Microplate readers
- Clinical diagnostics
- DNA & cell analysis
- Particle measurements
- Industrial spectroscopy
- Nucleic acid amplification (PCR)

Features and Benefits

- Extremely low background noise
- Best low light level detection limits
- High dynamic range & gain
- Low microphonic & magnetic sensitivity
- Compact size & rugged design
- Multiple photocathode and window selections
- Plug and play for shortest design-in and time-to-market
- Customizations and added features available

Product Description

PerkinElmer's Channel Photomultiplier (CPM) Technology offers a portfolio of ultra-high sensitivity optical detectors designed for extremely low noise, high dynamic range, highest gain and fast response for analytical, scientific and clinical diagnostic applications. A variety of easy-to-use modules with different read-out electronics is available, enabling customers to benefit from the unique performance characteristics of the CPM technology.

Depending on the application requirements, customers can select plug-and-play modules for photon counting, DC applications, photon-counting detection up to gigacount range or any other method of photon detection. Added features like thermoelectric cooling, shuttering and other sorts of customization are available upon request. The CPM modules are ideally suited for use in human and environmental health, supporting the market needs for ever smaller sample sizes and lower detection limits in applications like microplate readers, nucleic acid amplification (PCR), luminescence or fluorescence spectroscopy.

Product Table

Channel Photomultipliers & Modules

CPM Tube Model (also as P-Type ^{1,2})	Spectral Response	Active Diameter (min.)	Remarks, Other Available Types	Dark Current/ pA @ 1e5	Equivalent Noise Input (ENI)/W _{1/2} (Hz) at Peak Resp. Wavel. (typ.)	Peak Wavelength (typ., nm)	Dark Counts for -P Type and MH-P (typ.)
Unit	nm	mm		Gain (typ.)			
C911		5		0.1	1.0 e ⁻¹⁷		0.1
C1311	115 - 200	9	-	0.2	2.0 e ⁻¹⁷	140	0.4
C1911		15		0.5	3.0 e ⁻¹⁷		1
C922		5		0.5	1.0 e ⁻¹⁷		1
C1322	165 - 320	9	MgFl window available	1	2.0 e ⁻¹⁷	200	4
C1922		15		2	3.0 e ⁻¹⁷		10
C943		5		2	1.0 e ⁻¹⁷		10
C1343	185 - 650	9		8	2.0 e ⁻¹⁷	400	40
C1943		15		20	3.0 e ⁻¹⁷		100
C984		5		1	6.0 e ⁻¹⁸		2
C1384	300 - 670	9		4	1.0 e ⁻¹⁷	350	10
C1984		15		10	2.0 e ⁻¹⁷		20
C993		5		2	1.0 e ⁻¹⁷		5
C1393	185 - 750	9	Quartz, Boro. window available	8	2.0 e ⁻¹⁷	450	20
C1993		15		20	3.0 e ⁻¹⁷		50
C963		5		20	4.0 e ⁻¹⁷		100
C1363	185 - 850	9	Quartz window available	80	8.0 e ⁻¹⁷	450	400
C1963		15		200	1.0 e ⁻¹⁶		1000
C973		5		100	1.5 e ⁻¹⁶		500
C1373	185 - 900	9	Quartz window available	400	3.0 e ⁻¹⁶	500	2000
C1973		15		1000	5.0 e ⁻¹⁶		5000

1. P- types are Photoncounting suitable CPM or module types. When ordering please add -P : e.g.: C993-P, MH984-P

2. Also order number

Ordering Guide

Series	Description
MH series	All modules are available with optical input aperture of 9 mm (9xx-series), 13 mm (13xx-series) and 19 mm (19xx-series). Modules with direct anode output (comprising CPM and high voltage supply only)
MH P-type	MH modules with CPM tube specially selected for photon-counting applications
MD series	Modules for DC measurement, analog output: 0 to 10 Volts
MP series	Modules optimized for photon counting, digitized output via TTL interface
MPRS series	Modules optimized for photon counting, digitized output via RS232 interface
MPC series	Temperature stabilized (TE-cooled) MP modules, customized OEM projects only
GPDM series	Highest dynamic range (single photon/s to 1G photon/s range) module with digital output for fluorescence and luminescence measurements and other demanding applications.

General Specification

Parameter	Remarks/ Conditions	Symbol	CPM (tube)	MH-Module MH-P-Type	MD	MP MPC	MPRS	GPDM	Unit
Window materials	MgF2, quartz, UV glass, borosilicate		✓	✓	✓	✓	✓	✓	
Photocathode materials	CsI, CsTe, low noise bialkali, bialkali, yellow enhanced, multialkali, extended red multialkali		✓	✓	✓	✓	✓	✓	
Max. input current	Module input current	I_{DD}		200	250	250 ²	250	300	mA
Bias current (typ.)	CPM input current	I_{bias}	40						μ A
Supply voltage/ Input voltage	Modules include CPM high voltage supply	V_{DD}	2000V (typ.) 2600V (max.)	+5 to +5.5 (max.)	+5 to +5.5 (max.)	+5 to +5.5 (max.)	+5 to +5.5 (max.)	+5 to +5.5 (max.)	Volts dc
Current amplification	6e6 (typ.), 1e8 (max.)		✓	✓	✓	✓	✓	(see note 3)	
Max. anode current	Output current (max. 30sec.)	I_{anode}	10	10					μ A
Linear anode current	Max. (DC linearity limit) 10% of bias current ¹	I_{lin}	✓	✓					
Linear count rate (typ)	(see note 1)	CPS _{lin}				20	10	1000	Mcps
Response time	Output pulse rise time	t_{resp}	3	3		3			ns
Transit time		t_t	17	17					ns
Transit time spread	Timing resolution/jitter	t_{ts}	2	2					ns
Output pulse width (FWHM)	Typical value	PW	6	6		20			ns
Over-illumination protection	Active gate control				✓	✓	✓	✓	
Output impedance	Termination for fast output pulse		50	50		50		Digital	Ohms
Active gate control	TTL-pulse, active high		✓	✓	✓	✓	✓	✓	
GATE voltage	TTL-level: low to high/high to low	V_{gate}		100/300	100/300	0.02/0.02		100/300	μ s
Operating temperature	+5 to +40°C (other temperatures on request)	t_{op}	✓	✓	✓	✓	✓	✓	
Storage temperature	-20 to +50°C	t_{store}	✓	✓	✓	✓	✓	✓	
Weight	max. 350g/420g/450g (modules 9xx-series/13xx-series/19xx-series)								
Output			Anode signal	Anode sig.	0–10V	TTL	RS232	USB/SPI	

1. For long term operation: max. average output countrate of <100Kcps (anode current of <100nA) is recommended
2. Cooling input power: 9VDC/3.5A Fan input power: 24VDC/100mA

3. Gain setting depending on operating mode – see separate datasheet

Graph 1

Spectral Response

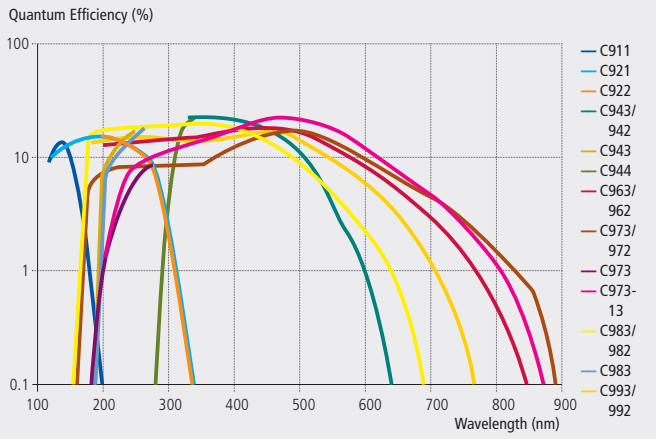

Graph 2

Equivalent Noise Input

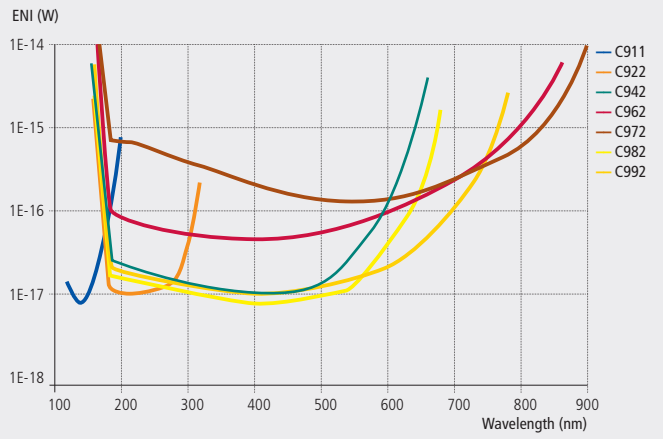

Housing / Package Drawings

Dimensions (mm) Module Type	A	B	C	D	E	F	G	H	I	J	K	L	M
9xx	4.5	36	4.5	33	127	120	30	20	19.5	10	18	45	45
13xx	4.5	36	7	33	132	125	30	20	19	10	22.1	50	50
19xx	4.5	36	7	33	137	130	30	20	19	10	22.1	50	50

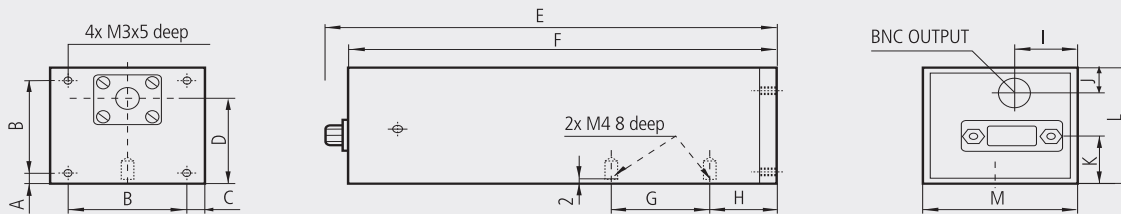

PHOTOMULTIPLIERS FOR MOLECULAR DETECTION IN ANALYTICAL APPLICATIONS & MEDICAL DIAGNOSTICS

MODULES AND OPTICAL RECEIVERS ■

Gigahertz Photon
Detection Module



Gigahertz Photon Detection Module

Applications

- Multimodal analytical measurements
- Luminescence spectroscopy
- Time-resolved fluorescence
- High through-put screening
- DNA & cell analysis
- Microplate reading

Features and Benefits

- Extremely low background noise
- Highest dynamic range
- High gain
- 4 different operating modes
- Variable Interface options
- Best suited for multimodal analytical applications

Product Description

The new CPM Gigahertz Photon Detection Module (GPDM) provides the capability of ultra low-light-level detection in DC mode operation. Using DC mode operation with single-photon-sensitivity makes the GPDM module superior to traditional counting circuits with their performance limitation at high-light-levels. The fully equipped module includes the Channel Photomultiplier, the high voltage supply, analog current amplifier, A to D conversion and a microcontroller with USB/SPI interface allowing the optimal adaptation to a wide range of applications. Additional features like the synchronization I/O offer the possibility to synchronize the measurement with other devices in the application like flash lamp trigger etc. Utilizing the generic noise advantage of the CPM technology together with highest dynamic range electronics the GPDM represents a real innovation in photon detection, well suited to increase overall OEM system performance.

Technical Specification

Gigahertz Photon Detection Module

Parameter	Condition	Min	Typ	Max	Units
Supply voltage	-	5.0	5.3 ²	5.6	VDC
Supply current	-	-	300	-	mA
Detection range¹	Real counting mode	1	-	1e4	Counts per second ⁴
	Straight output mode	1	-	5e7	Counts per second ⁴
	Fast switching mode	1	-	1e9	Counts per second ⁴
	HV reduction mode	3e5	-	1e10	Counts per second ⁴
Switching dead time	w/o offset calibration	-	1	-	ms
In fast switching mode	Including offset calibration	-	20	-	ms
QE²	λ_{peak}	-	20 %	-	Photoelectrons/ photons
CPM gain³	-	1E3	adjustable	-	-
Sample time	Continuous data output	200	-	5000	ms
	(under development)	1	-	5000	ms
Acquisition time	Width of measurement	3	-	200	μ s
	Window for flash sequence measurements	-	-	-	-
Interface	USB 2.0	-	2	-	Mbit/second
	SPI (under development)	-	-	-	-

1. See below performance characteristics

2. CPM characteristics can be matched to the application's requirements – see spectral response curve

3. Gain pre-set to optimal single photons sensitivity

4. Actual output information is RLU (Relative Light Unit) – counts per second is the μ C calculated value based on RLU

5. Recommended for best performance

Figure 1

Block Diagram Gigahertz Photon Detection Module

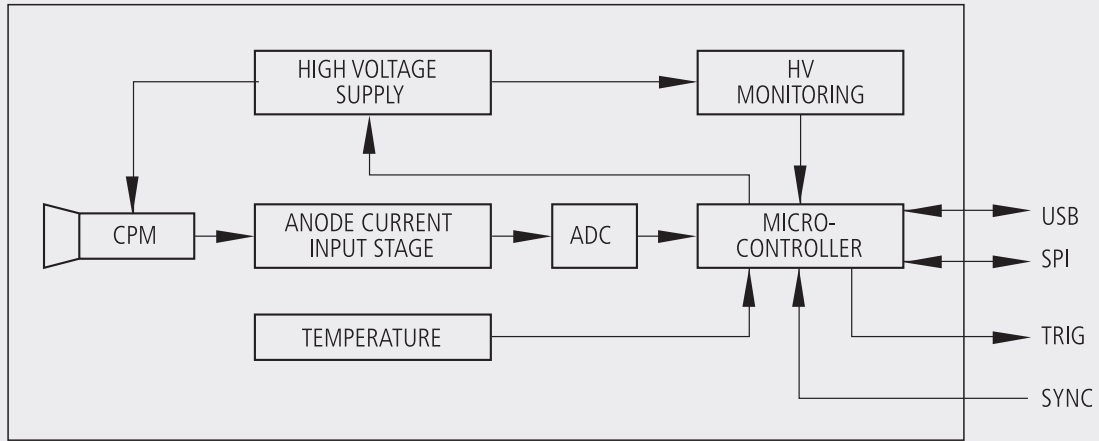

Graph 1

Straight Output Mode

Measurement Bandwidth Straight Output Mode at 1 S/s

Data Readout, Pulses per second (Cps)

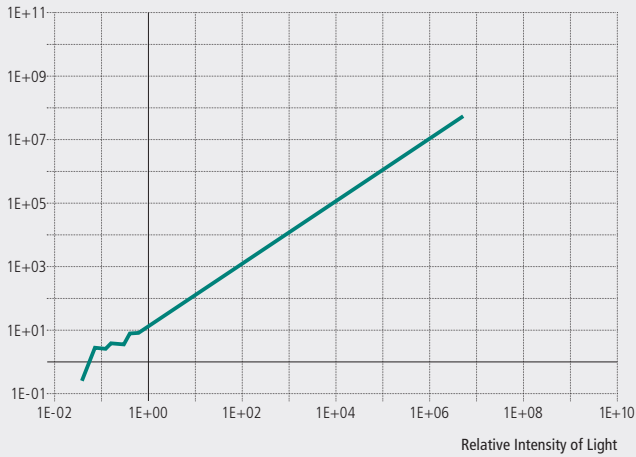

Graph 2

Fast Switching Mode

Measurement Bandwidth Extended Range/
Fast Switching Mode at 1 S/s

Data Readout, Pulses per second (Cps)

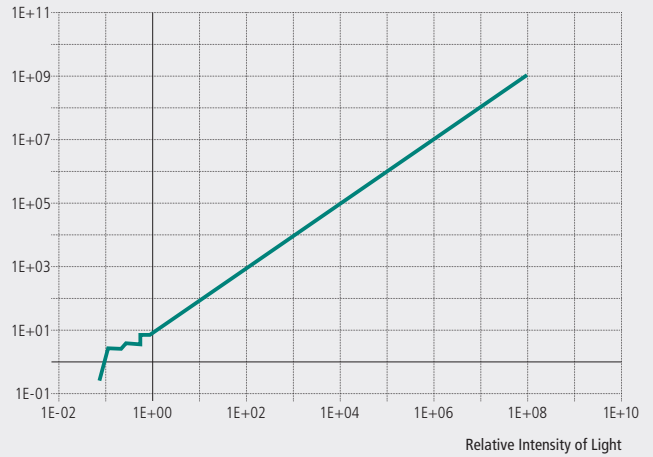

Graph 3

High Voltage Reduction Mode

Measurement Bandwidth Extended Range/
HV Reduction Mode at 1 S/s

Data Readout conv. to Pulses per second (Cps)

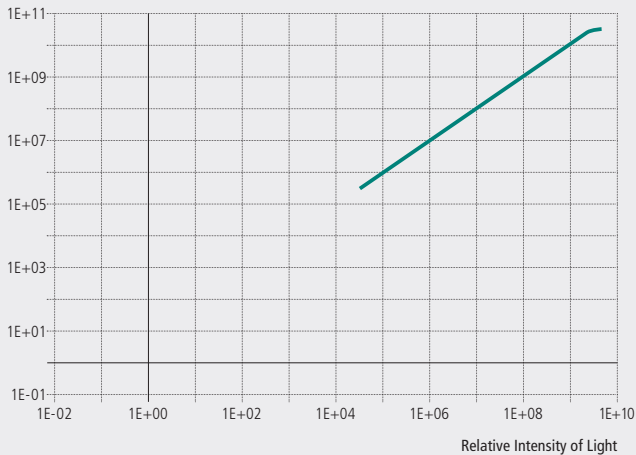

Graph 4

Real Counting Mode

Measurement Bandwidth Real Counting Mode at 1 S/s

Data Readout, Pulses per second (Cps)

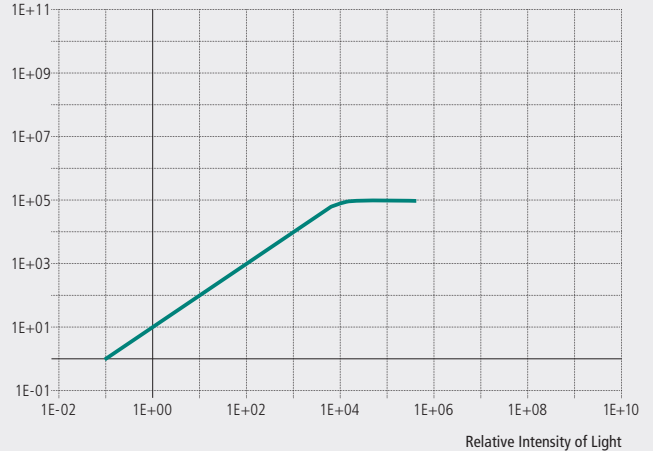

HIGH SPEED HIGH SENSITIVITY LINEAR CAMERAS FOR MACHINE VISION

MODULES AND OPTICAL RECEIVERS ■

SmartBlue™ Linear Camera

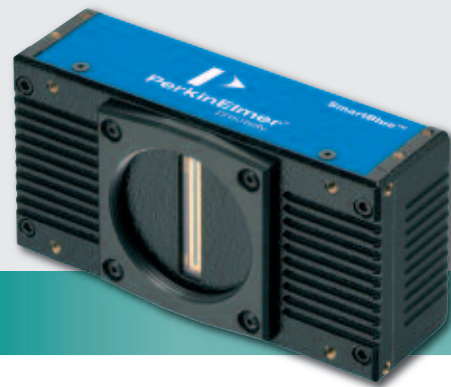

CCD Linear Cameras – SmartBlue™ Linear Camera

Applications

- High speed machine vision
- Postal / parcel sorting
- Web inspection
- Surface inspection
- OCR / barcode reading web inspection

Features and Benefits

- High speed, up to 80 MHz data rate.
- 14 μm square pixels in 512, 1024, 2048 or 4096 element resolutions.
- Small size 101.6 x 57.2 x 38.1 mm
- 8/10/12-bit output format
- High line rates up to 68 kHz
- 66 db dynamic range
- High sensitivity pinned photodiode CCD sensor
- CameraLink™ base output
- User controlled smart pixel correction
- Antiblooming control
- Single 12VDC power supply
- Electronic exposure control
- Adjustable gain levels
- Real time status LEDs
- Ultra-low image lag
- Square pixels with 100% fill factor
- Extended spectral range – 200 – 1000 nm

Product Description

The SmartBlue™ digital linescan cameras incorporate the latest in photodiode array technology based on the industry standard Reticon® devices with state of the art electronics and a robust industrial camera housing. The linescan photodiode array is a pinned photodiode Charge Couple Device which allows for high sensitivity, fast readout, while maintaining high dynamic range, and low image lag. The SmartBlue™ cameras are cost effective high-performance digital linescan cameras, and feature a CameraLink™ digital interface. These cameras feature geometrically precise photodiode CCD image sensor with 14 μm square pixels with resolutions of 512, 1024, 2048 and 4096 pixels. This “next generation” array can achieve data rates up to 80 MHz with superior noise immunity, precise linearity, and high CTE. The SmartBlue™ digital cameras are designed for high line rate applications with low to moderate light conditions and where small size, and low cost are required.

Technical Specification

SmartBlue™ Linear Camera

Part Number	Resolution	Window	Aperture Length	Max. Line Rate
SB0440CLG-011	512	Glass	7.2 mm	68 kHz
SB0440CLQ-011	512	Quartz	7.2 mm	68 kHz
SB1440CLG-011	1024	Glass	14.4 mm	36.4 kHz
SB1440CLQ-011	1024	Quartz	14.4 mm	36.4 kHz
SB2480CLG-011	2048	Glass	28.7 mm	37.3 kHz
SB2480CLQ-011	2048	Quartz	28.7 mm	37.3 kHz
SB4480CLG-011	4096	Glass	57.3 mm	19.1 kHz
SB4480CLQ-011	4096	Quartz	57.3 mm	19.1 kHz

Technical Specification

Spectral Sensitivity Curve (1x Gain)

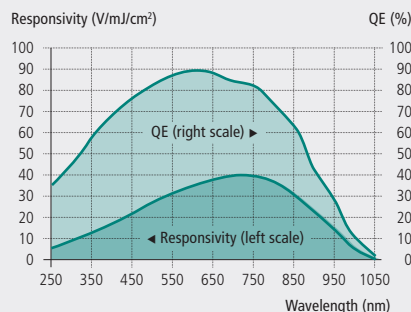

Technical Specification

Package Drawing*

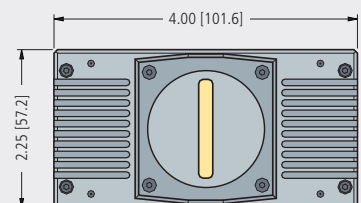

* not for SB4480CLX

HIGH SPEED HIGH SENSITIVITY LINESCAN IMAGERS FOR MACHINE VISION

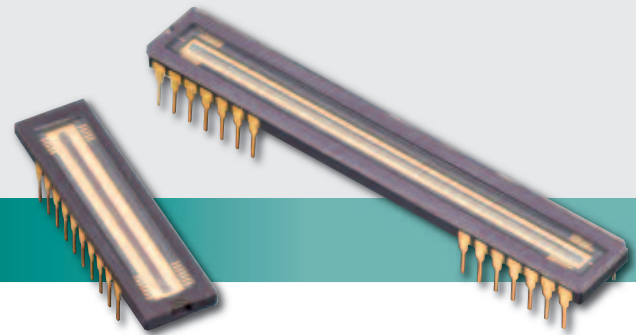

CCD Linear Imagers

Applications

- Web inspection
- Mail sorting
- Production measurement
- Position sensing
- Spectroscopy
- High speed document reading

Features and Benefits

- 2500:1 dynamic range
- Ultra-low image lag
- Electronic exposure control
- Antiblooming control
- Square pixels with 100% fill factor
- Extended spectral range – 200–1000 nm

Product Description

PerkinElmer's P-series linear imager combines the best features of high-sensitivity photodiode array detection and high speed, charge-coupled scanning to offer an uncompromising solution to the increasing demands of advanced imaging applications. These high-performance imagers feature low noise, high sensitivity, impressive charge-storage capacity, and lag-free dynamic imaging. The 14 μm square contiguous pixels in these imagers reproduce images with minimum information loss and artifact generation, while their unique photodiode structure provides excellent blue response extending below 200 nm in the ultraviolet. These versatile imagers are available in array lengths of 512 to 4096 elements with either low-cost glass or UV-enhanced fused silica windows.

Technical Specification

P-Series CCD Linear Array

Part Number	Pixel Count Elements	Pixel Size μm	Number of Outputs	Spectral Response Range nm	Pixel Data Rate MHz	Dynamic Range	Horizontal Clocking typ.
RL0512P	512	14 x 14	1	200–1000	40	2500:1	2 σ @ 5V
RL1024P	1024	14 x 14	1	200–1000	40	2500:1	2 σ @ 5V
RL2048P	2048	14 x 14	1	200–1000	40	2500:1	2 σ @ 5V
HL2048P	2048	14 x 14	2	200–1000	80	2500:1	2 σ @ 5V
HL4096P	4096	14 x 14	2	200–1000	80	2500:1	2 σ @ 5V

Technical Specification

Quantum Efficiency

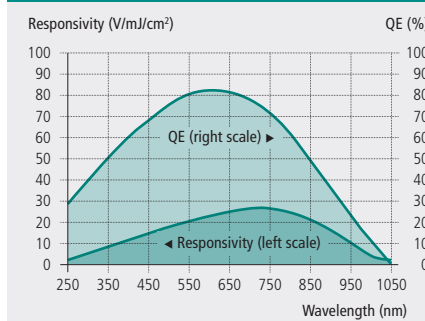

HIGH SENSITIVITY LARGE FORMAT PIXELS FOR SPECTROSCOPY

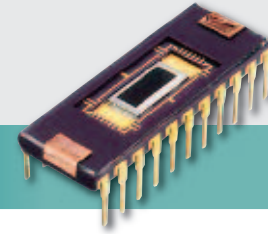

CMOS Linear Photodiode Arrays – L-Series

Applications

- Spectroscopy
- Colorimetry

Features and Benefits

- 2.5 mm photodiode aperture
- Extremely low dark leakage current
- Low power dissipation
- Clock-controlled sequential readout at rates up to 1 MHz
- Single-supply operation with HCMOS-compatible inputs
- Single shift register design
- Wide dynamic range
- Differential video output for clock noise cancellation
- High saturation charge 10 pC (25 μm) or 20 pC (50 μm)
- Antiblooming function for low crosstalk
- Line reset mode for simultaneous reset of all photodiodes
- Wide spectral response: 300 to 1000 nm
- Polished fused silica window
- Two on-chip diodes for temperature monitoring

Product Description

PerkinElmer's L-series CMOS linear photodiode arrays offer a high-quality, low-cost solution for spectroscopy and colorimetry applications in the 300–1000 nm range. The L-series family's combination of high sensitivity, low dark current, low switching noise and high saturation charge provides excellent dynamic range and great flexibility in setting integration time. L-series sensors consist of a linear array of silicon photodiodes, each connected to a MOS switch for readout controlled by an integrated shift register scanning circuit. Under external clock control, the shift register sequentially enables each of the switches, directing the charge on the associated photodiode to an output line. A dummy output provides clock noise cancellation. L-series devices are mounted in ceramic side-brazed, 22-pin, dual-inline packages with ground and polished fused silica windows and are pin-compatible with earlier PerkinElmer SB and TB-series sensors. L-series models are available with pixel spacings of 25 μm and 50 μm and lengths from 128 to 1024 pixels. All models feature a 2500 μm pixel aperture to simplify alignment in spectroscopic instruments.

Technical Specification

P-Series CCD Linear Array

Part Number	Video Capacitance		Sensitivity C _i /cm ²	Saturation Exposure nJ/cm ²	Saturation Charge pC	Dynamic Range	Dark Current Typ. pA
	@ 5V bias pF	@ 2.5V bias pF					
RL1201	–	6.7	2 x 10 ⁻⁴	50	10	70.000	0.2
RL1202	–	10.2	2 x 10 ⁻⁴	50	10	70.000	0.2
RL1205	–	15.4	2 x 10 ⁻⁴	50	10	70.000	0.2
RL1210	–	28.7	2 x 10 ⁻⁴	50	10	70.000	0.2
RL1501	9.1	–	4 x 10 ⁻⁴	50	20	100.000	0.4
RL1502	14	–	4 x 10 ⁻⁴	50	20	100.000	0.4
RL1505	25	–	4 x 10 ⁻⁴	50	20	100.000	0.4

Operating Temperature: 0°C min. to +55°C max. Lag: <1 %
Storage Temperature: -25°C min. to +85°C max. Saturation Voltage: 600 mV

Technical Specification

Quantum Efficiency

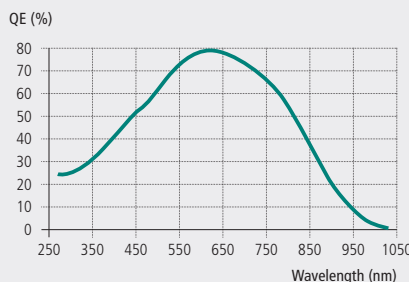

Technical Specification

P-Series CCD Linear Array

Pixels	Pixel Pitch 25 μm	Pixel Pitch 50 μm
128	RL1201LGQ-711	RL1501LFQ-711
256	RL1202LGQ-711	RL1502LFQ-711
512	RL1205LGQ-711	RL1505LFQ-711
1024	RL1210LGQ-711	–

PIN AND APD RECEIVER MODULES

FOR ANALYTICAL AND
INDUSTRIAL APPLICATIONS

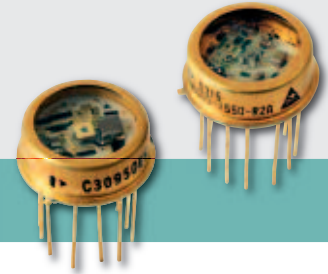

Si PIN and APD Modules – InGaAs APD Modules

Applications

- Laser range finder
- Confocal microscopy
- Video scanning imager
- High speed analytical instrumentation
- Free space communication
- UV light sensing
- Distributed temperature sensing

Features and Benefits

- Ultra low noise
- High speed
- High transimpedance gain

Product Description

These modules comprise of a photodetector (PIN or APD) and a transimpedance amplifier in the same hermetically sealed package. Having both amplifier and photodetector in the same package allows low noise pickup from the surrounding environment and reduces parasitic capacitances from interconnect allowing lower noise operation.

The hybrid amplifier C30659 series includes an APD connected to a low noise transimpedance amplifier. 4 models are offered with Silicon APD and 2 models with InGaAs APD. Standard bandwidth of 50 MHz and 200 MHz can accommodate a wide range of applications. Two C30659 models are offered with the APD mounted on a Thermo-electric cooler (the LLAM series) to help improving noise or to keep the APD at constant temperature regardless of the ambient temperature.

The C30659 can be customized to meet application specific requirements by using one of the PerkinElmer rear entry APDs, by choosing a custom bandwidth or by qualifying it to your environmental conditions. Pigtailed versions are also available in a 14 pins DIL package allowing nearly 100% coupling efficiency.

The C30950EH offers a low cost alternative to the C30659. The amplifier is designed to neutralize the input capacitance of a unity voltage gain amplifier. The C30919E uses the same architecture of the C30950EH with the addition of a high voltage temperature compensation circuit which maintain module responsivity constant over a wide temperature range.

Two HUV modules are offered with a PIN detector for low frequency high gain application, covering a broad spectrum range from the UV to the near IR.

All optical receiver products can be qualified to meet the most demanding environmental specification as described in MIL-PRF-38534.

Product Table

Si PIN and APD Modules – InGaAs APD Modules

Unit	Detector	Active Area mm ²	Bandwidth MHz	Responsivity, 830 nm kV/W	Responsivity, 900 nm kV/W	Responsivity, 1060 nm kV/W	NEP fW/√Hz	Output Voltage Swing, 50 Ohm V	Package
C30659-900-R5BH	C30902	0.5	200	460	400	-	35	0.9	TO-8
C30659-900-R8AH	C30817	0.8	50	2700	3000	-	14	0.9	TO-8
C30659-1060-R8BH	C30954	0.8	200	-	370	200	55	0.9	TO-8
C30659-1060-3AH	C30956	3	50	-	450	280	55	0.9	TO-8
C30659-1550-R08BH	C30645	80 μm	200	-	90 @ 1550 nm	-	220	0.9	TO-8
C30659-1550-R2AH	C30645	200 μm	50	-	340 @ 1550 nm	-	130	0.9	TO-8
C30919E	C30817	0.8	40	-	1000	250	20	0.7	TO, 1 in
C30950EH	C30817	0.8	50	520	560	140	27	0.7	TO-8
LLAM-1550-R2AH	C30662	0.2	50	-	340 @ 1550 nm	-	130	0.9	TO-8 flange
LLAM-1060-R8BH	C30954	0.8	200	-	370	200	55	0.9	TO-8 flange
HUV-1100BGH	UV-100	2.5	1 kHz	-	130 MV/W	-	30	5 min	Custom
HUV-2000BH	UV-215	5.4	1 kHz	-	130 MV/W	-	70	5 min	Custom

PHOTODIODE ARRAYS FOR X-RAY SECURITY APPLICATIONS

PHOTODIODE ARRAYS FOR X-RAY SECURITY SCANNING ■

Left: 16 Element, 1.6 mm Pitch Photodiode Array With Segmented CsI Scintillator.

Right: 16 Element, 2.5 mm Pitch Photodiode Array With GOS Low Energy Screen Scintillator.

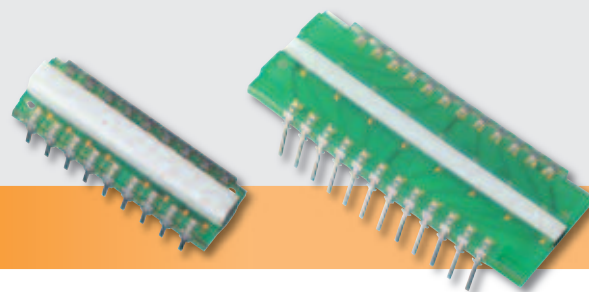

Photodiode Arrays – VTA Series

Applications

- Luggage scanning
- Cargo & container scanning
- Food inspection
- Non-destructive testing

Features and Benefits

- Various crystal types available (CsI, GOS, etc.)
- Custom chip geometry & pitch
- Single or dual-sided assemblies
- High responsivity and low capacitance
- Onboard electronics available on a custom basis
- Multiple photodiode rows

Product Description

These photodiode arrays are used to generate an X-ray image by scanning an object line by line. The X-rays are converted into light through the attached scintillator crystal. The light intensity is then measured by the photodiodes. The boards are employing chip-on-board technology with optically adapted scintillator crystals. The listed designs can be ordered as a standard part, but can also be customized to meet the needs of a wide variety of applications. PerkinElmer custom photodiode arrays give customers the option to choose the:

- active photodiode area
- total number of elements
- overall PCB and photodiode chip dimensions
- photodiode chip geometry and orientation
- electro-optical specifications
- single sided vs. double sided PCB
- alternative substrate materials (e.g. ceramic)
- electrical interface (e.g. connector)

First stage amplification electronics can also be added to the custom board design to convert the current generated by the photodiode into an easy to measure voltage.

Product Table

Photodiode Arrays • VTA Series

Symbol	Substrate		Active Area	Photodiode Chip Dimensions	Pitch	Number of Elements	Scintillator Crystal Type	Light Current Uniformity @ 540 nm, 30 nW/cm ²	Dark Current @ H = 0, VR = 10 mV		Junction Capacitance @ H = 0, VR = 0 V		Radiometric Sensitivity @ 540 nm
	Material	Dimensions							Design	Design	typ	max	typ
	Unit	mm		mm ²	mm	mm	%	I _D	I _D	C _J	C _J	S _R	
VTA2164H-D-NC-00-0	FR4	43.2x67.7	1.41	1.40x3.50	2.1	64	Custom	±5	<10	90	<100	200	0.30
VTA1616H-H-SC-01-0	FR4	8.0x25.4	2.58	1.51x3.25	1.6	16	CsI	±5	-	50	-	350	0.30
VTA1616H-L-SC-02-0	FR4	16.0x25.4	2.58	1.51x3.25	1.6	16	GOS	±5	-	50	-	350	0.30
VTA2516H-H-SC-01-0	FR4	8.0x40.0	5.20	2.45x3.15	2.5	16	CsI	±5	-	50	-	600	0.30
VTA2516H-L-SC-02-0	FR4	16.0x40.0	5.20	2.45x3.15	2.5	16	GOS	±5	-	50	-	600	0.30
VTA1216H-H-NC-00-0	FR4	10.2x19.0	3.44	2.30x4.95 (dual cell)	1.2	16	Custom	±5	-	100	-	300	0.30
VTA1216H-L-NC-00-0	FR4	17.8x19.0	3.44	2.30x4.95 (dual cell)	1.2	16	Custom	±5	-	100	-	300	0.30
VTA0832H-H-NC-00-0	FR4	17.8x25.4	0.50	1.59x2.34 (dual cell)	0.8	32	Custom	±5	-	100	-	100	0.30

Electrical characteristics at T_{Ambient} = 25 °C

Figure 1

Side 1 Detail VTA2164H-D

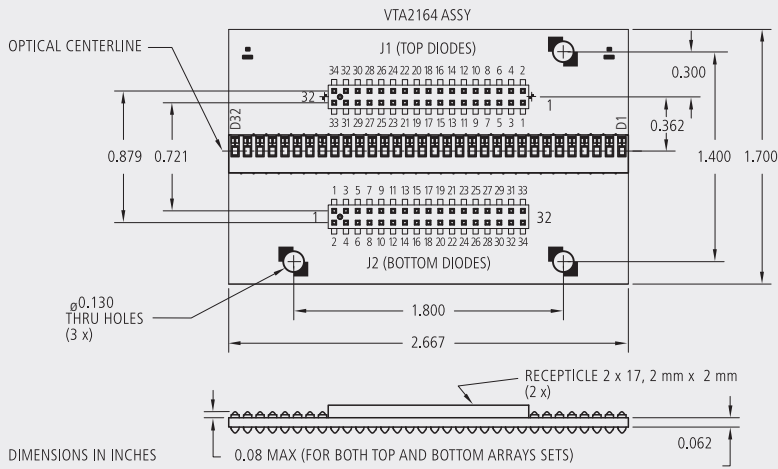

Figure 2

Side 2 Detail VTA2164H-D

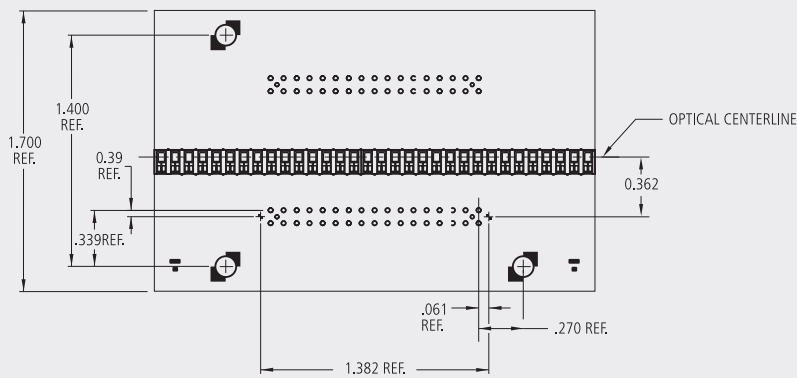
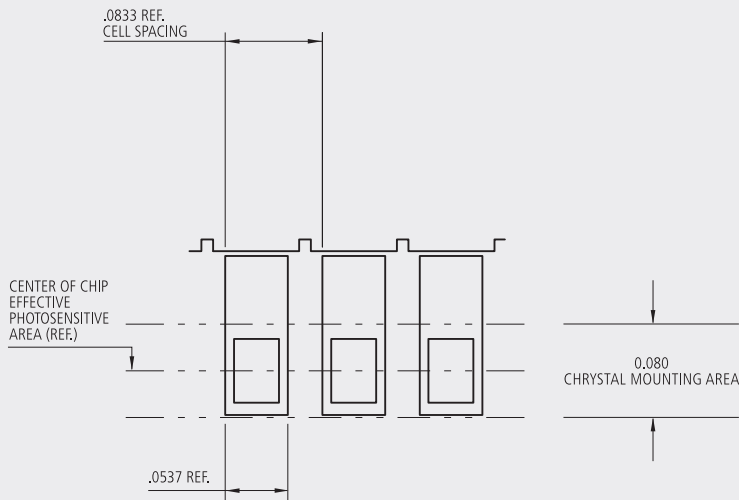

Figure 3

Chip Spacing Details, Side 1 (Typ) VTA2164H-D

Photosensitive Area 0.0545" x 0.0385 (Typ.) or 0.0021 SQ. IN.



Pin Out VTA2164H-D

Connector J1 (Top Diodes)		Connector J2 (Bottom Diodes)	
Pin	Connection	Pin	Connection
1	D1	1	D1
2	D2	2	D2
3	D3	3	D3
4	D4	4	D4
5	D5	5	D5
6	D6	6	D6
7	D7	7	D7
8	D8	8	D8
9	D9	9	D9
10	D10	10	D10
11	D11	11	D11
12	D12	12	D12
13	D13	13	D13
14	D14	14	D14
15	D15	15	D15
16	D16	16	D16
17	D17	17	D17
18	D18	18	D18
19	D19	19	D19
20	D20	20	D20
21	D21	21	D21
22	D22	22	D22
23	D23	23	D23
24	D24	24	D24
25	D25	25	D25
26	D26	26	D26
27	D27	27	D27
28	D28	28	D28
29	D29	29	D29
30	D30	30	D30
31	D31	31	D31
32	D32	32	D32
33	N/C	33	N/C
34	Common	34	Common

Figure 4

Pos. of Top Diodes Rel. to Bottom Diodes VTA2164H-D

(Optical Center Line to Optical Center Line)

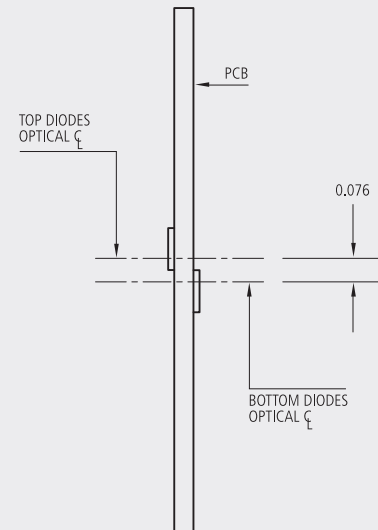

AVALANCHE PHOTODIODES FOR INDUSTRIAL & ANALYTICAL APPLICATIONS

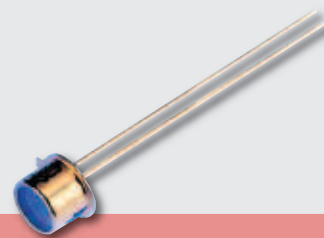

Avalanche Photodiodes – Silicon and InGaAs APDs

Applications

- Laser range finder
- Scanning video imager
- Confocal microscope
- Free space communication
- Spectrophotometers
- Fluorescence Detection
- Luminometer
- DNA sequencer
- Particle sizing

Features and Benefits

- Low noise
- High gain
- High quantum efficiency
- Built-in TE-cooler option
- Various optical input options

Product Description

These rear entry “reach-through” silicon APDs offer the best compromise in terms of cost and performance for applications requiring high speed and low noise photon detection from 400 nm up to 1100 nm. They feature low noise, high quantum efficiency and high gain while maintaining reasonably low operating voltage. The active area varies from 0.5 mm to 3 mm to accommodate a large variety of applications.

The “S” series of the C30902 family of APDs can be used in either their normal linear mode ($V_R < V_{BR}$) or as photon counter in the Geiger mode ($V_R > V_{BR}$). This series is particularly well-suited for ultra-sensitive photon measurements in biomedical and analytical instruments.

Precise temperature control can be achieved with a thermo electric cooler which can be used to improve noise and responsivity or to maintain constant responsivity over a wide range of ambient temperature.

High quantum efficiency can be achieved from 1100 nm to 1700 nm with our InGaAs Avalanche Photodiodes. They were designed to maintain high gain, high quantum efficiency and high bandwidth even with their large area of up to 200 μm . The short distance between to window and the active area allows easy interface with optical system.

Technical Specification

Avalanche Photodiodes – Silicon and InGaAs APDs

Unit	Active Diameter	Capacitance	Rise/Fall Time	Dark Current	Breakdown Voltage min	Breakdown Voltage max	Temperature Coefficient	Typical Gain	Responsivity 830 nm	Responsivity 900 nm	Responsivity 1060 nm	NEP	Package
	mm	pF	ns	nA	V	V	V/°C		A/W	A/W	A/W	fW/√Hz	
C30817EH	0.8	2	2	50	300	475	2.2	120		75		1	TO-5
C30872EH	3	10	2	100	325	500	2.2	60		37	9	30	TO-8
C30884E CDxx	0.8	4	1	100	190	290	1.1	100		63	8	13	TO-5
C30902BH	0.5	1.6	0.5	15	185	265	0.7	150	77	60		3	Ball lens TO-18
C30902BFCH	0.5	1.6	0.5	15	185	265	0.7	150	77	60		3	FC receptacle
C30902BSTH	0.5	1.6	0.5	15	185	265	0.7	150	77	60		3	ST receptacle
C30902EH	0.5	1.6	0.5	15	185	265	0.7	150	77	60		3	TO-18, flat window
C30902SH	0.5	1.6	0.5	15	185	265	0.7	250	128	108		0.9	TO-18, flat window
C30916EH	1.5	3	3	100	315	490	2.2	80		50	12	20	TO-5
C30921EH	0.25	1.6	0.5	15	185	265	0.7	150	77	60		3	TO-18, flat window
C30921SH	0.25	1.6	0.5	15	185	265	0.7	250	128	108		0.9	TO-18, light pipe
C30954EH	0.8	2	2	50	300	475	2.4	120		75	36	13	TO-5
C30955EH	1.5	3	2	100	315	490	2.4	100		70	34	14	TO-5
C30956EH	3	10	2	100	325	500	2.4	75		45	25	25	TO-8

Silicon APD – TE-Cooled

Unit	Active Diameter	Active Area	Total Capacitance	Rise/Fall Time	Dark Current	Breakdown Voltage min	Breakdown Voltage max	Temperature Coefficient	Typical Gain	Responsivity 830 nm	Responsivity 900 nm	Responsivity 1060 nm	Noise Current	Package
	mm	mm ²	pF	ns	nA	V	V			A/W	A/W	A/W	pA/sqrt(Hz)	
C30902SH-TC	0.5	0.2	1.6	0.5	2	225	-	0.7	250	128	108	-	0.04	TO-8 flange
C30902SH-DTC	0.5	0.2	1.6	0.5	1	225	-	0.7	250	128	108	-	0.02	TO-8 flange
C30954E-TC	0.8	0.5	2	2	50	300	475	2.4	120	-	75	-	0.2	TO-8 flange
C30954E-DTC	0.8	0.5	2	2	50	300	475	2.4	120	-	75	-	0.04	TO-8 flange
C30955E-TC	1.5	1.8	3	2	100	315	490	2.4	100	-	70	-	0.2	TO-8 flange
C30955E-DTC	1.5	1.8	3	2	100	315	490	2.4	100	-	70	-	0.05	TO-8 flange
C30956E-TC	3	7	10	2	100	325	500	2.4	75	-	45	-	0.2	TO-8 flange

TC stands for single stage cooler, operating temperature 0° C
 DTC stands for double stage cooler, operating temperature -20° C

InGaAs APD

Unit	Active Diameter	Capacitance	B _w	Dark Current	Breakdown Voltage min	Breakdown Voltage max	Temperature Coefficient	Typical Gain	Responsivity 1550 nm	NEP	Package
	µm	pF	MHz	nA	V	V	V/°C		A/W	fW/sqrt(Hz)	
C30662EH	200	2.5	800	70	40	90	0.14	10	9.3	100	TO-18
C30662ECERH	200	2.5	800	70	40	90	0.14	10	9.3	100	Ceramic carrier
C30645EH	80	1.25	1000	35	40	90	0.14	10	9.3	25	TO-18
C30645ECERH	80	1.25	1000	35	40	90	0.14	10	9.3	25	Ceramic carrier
C30644EH	50	0.6	2000	25	40	90	0.14	10	9.3	15	TO-18
C30644ECERH	50	0.6	2000	25	40	90	0.14	10	9.3	15	Ceramic carrier

Graph 1

Typical Spectral Responsivity @ 22° C

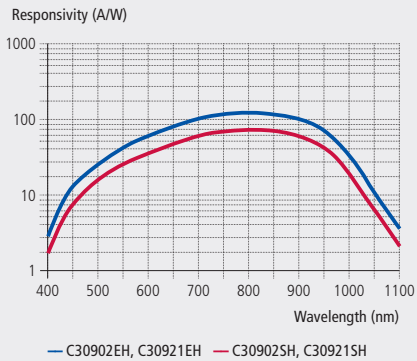

Figure 1

Package Drawing – TO-8 Flange

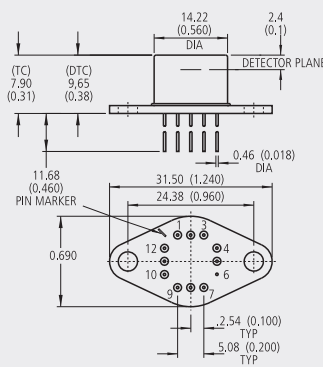

Figure 2

Typical TO-5 Package*

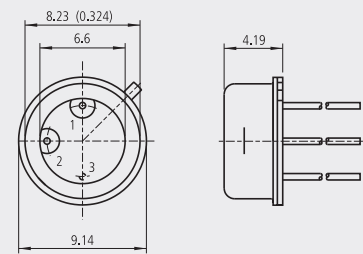

Figure 3

Typical TO-8 Package*

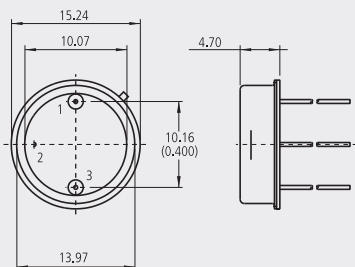

Figure 4

Ceramic Carrier

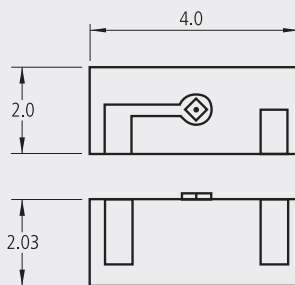
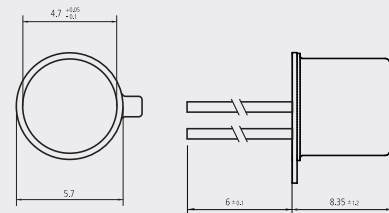

Figure 5

Typical TO-18 Package*



*Note: Package dimension for indication only. Exact package dimension can be found on products datasheets.

AVALANCHE PHOTODIODES FOR ANALYTICAL APPLICATIONS

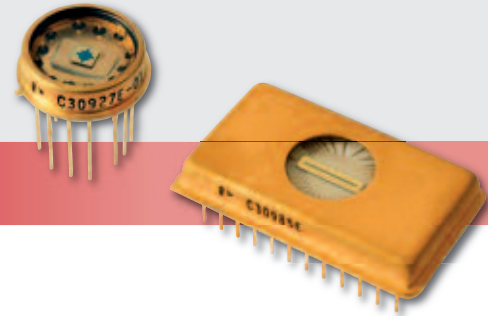

Avalanche Photodiodes – Si APD Arrays

Applications

- Spectroscopy
- Particle detection
- Spot tracking and alignment systems
- Adaptive optics
- Lidar

Features and Benefits

- High quantum efficiency
- Hermetically sealed packages
- Monolithic chip with minimal dead space between elements
- Specific tailored wavelength response
- RoHS compliant

Product Description

C30927 series of quadrant Si Avalanche Photodiode and the C30985E multi-element APD array utilize the double-diffused “reach-through” structure. This structure provides ultra high sensitivity at 400-1000 nm.

The C30927 quadrant structure has a common avalanche junction, with separation of the quadrants achieved by segmentation of the light entry p+ surface opposite the junction. With this design, there is no dead space between the elements and therefore no loss of response at boresight.

The C30927EH-01, -02 and -03 are optimized for use at wavelengths of 1060, 900, and 800 nm respectively. Each device type will provide high responsivity and excellent performance when operated within about 50 nm of the specified wavelength.

The C30985E is a 25 element monolithic linear APD array having a high inter-electrode resistance with a 75 μm dead space between the elements. Packages have a common ground and bias with a separate lead for each element output.

Product Table

Avalanche Photodiodes – Si APD Arrays

Part Number	Number of Elements	Photo Sensitive Diameter	Responsivity	Dark Current per Element	Spectral Noise Current	Capacitance @ 100 KHz	Response Time	NEP	NEP
Unit	mm	mm	A/W	nA	pA/Hz	pF	ns	fW/√Hz	V
C30927EH-01	4	1.5	15(@ 1060 nm)	25	0.5	1	3	33(@ 1060 nm)	275 - 425
C30927EH-02	4	1.5	62(@ 900 nm)	25	0.5	1	3	16(@ 900 nm)	275 - 425
C30927EH-03	4	1.5	55(@ 800 nm)	25	0.5	1	3	9(@ 800 nm)	275 - 425
C30985E	25	0.3	31(@ 900 nm)	1	0.1	0.5	2	3(@ 900 nm)	250 - 425

Figure 1

Package Drawing – C30927 Series

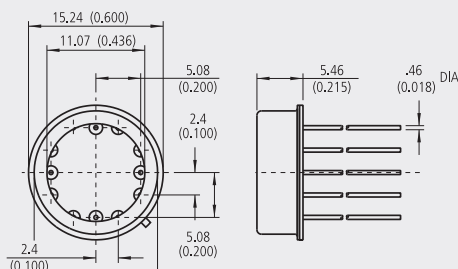
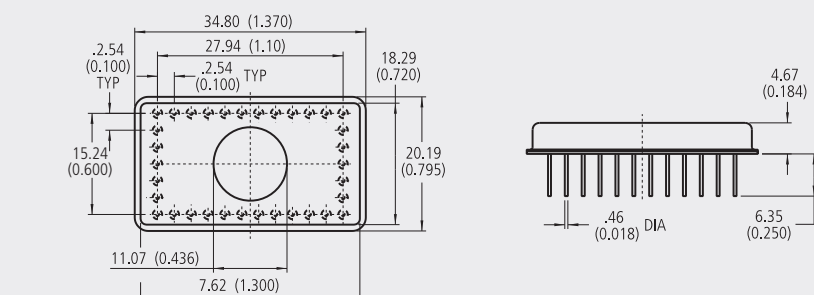
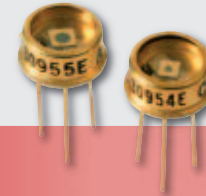

Figure 2

Package Drawing – C30985E



AVALANCHE PHOTODIODES FOR ANALYTICAL APPLICATIONS



1060 nm NIR Enhanced Si APDs

Applications

- Range finding
- Lidar
- YAG laser detection

Features and Benefits

- High quantum efficiency at 1060 nm
- Fast response time
- Wide operating temperature range
- Low capacitance
- Hermetically sealed packages
- RoHS compliant

Product Description

The C30954EH, C30955EH, and C30956EH are general purpose silicon avalanche photodiodes made using a double-diffused "reach-through" structure. The design of these photodiodes are such that their long wave response (i.e. >900 nm) has been enhanced without introducing any undesirable properties.

These APDs have quantum efficiency of up to 40 % at 1060 nm. At the same time, the diodes retain the low noise, low capacitance, and fast rise and fall times characteristics.

To help simplify many design needs, these APDs are also available in PerkinElmer's high-performance hybrid preamplifier module type C30659 series, as well as the preamplifier and TE cooler incorporated module type LLAM series. Please refer to the respective sections in this catalog.

Graph 1

Spectral Responsivity Characteristics

Typical Responsivity (A/W)

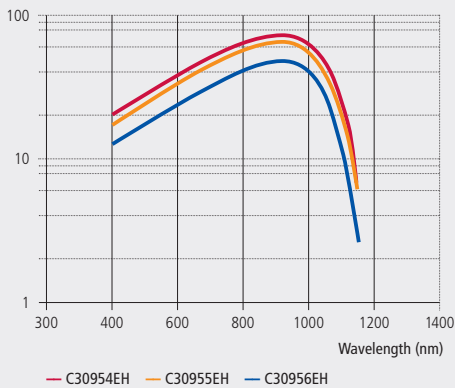

Product Table

Si APDs – NIR Enhanced

Part Number	Photo Sensitive Diameter	Respon-sivity @ 1060 nm	Dark Current	Spectral Noise Current	Capaci-tance @ 100 KHz	Response Time	NEP @ 1060 nm	Vop Range
Unit	mm	A/W	nA	pA/√Hz	pF	ns	fW/√Hz	V
C30954EH	0.8	36	50	0.5	2	2	14	275 - 425
C30955EH	1.5	34	100	0.5	3	2	15	275 - 425
C30956EH	3.0	25	100	0.5	10	2	20	275 - 425

Figure 1

Package Drawing – C30954EH, C30955EH

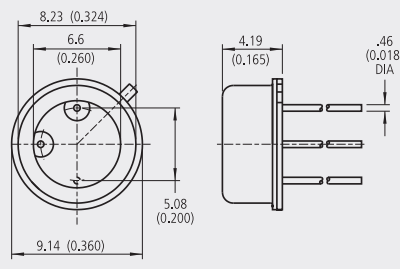
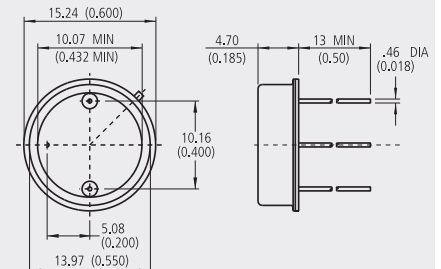
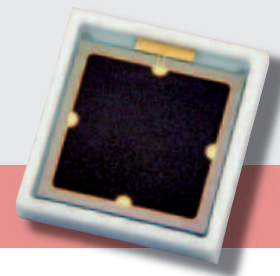

Figure 2

Package Drawing – C30956EH



AVALANCHE PHOTODIODES FOR HIGH ENERGY RADIATION DETECTIONS APPLICATIONS, MOLECULAR IMAGING



Large Area Si-APDs – UV-Enhanced APDs

Applications

- Nuclear medicine
- Fluorescence detection
- High energy physics
- Medical imaging
- Radiation detection
- Particle physics
- Instrumentation
- Environmental monitoring

Features and Benefits

- High quantum efficiency
- Low dark currents
- Easy coupling to scintillator crystals
- Immunity to electromagnetic fields
- Short wavelength enhanced responsivity
- Custom packaging available
- Excellent timing resolution
- RoHS compliant

Product Description

The C30739ECERH Silicon Avalanche Photodiode (APD) is intended for use in a wide variety of broadband low light level applications covering the spectral range from below 400 to over 700 nanometers. It has low noise, low capacitance and high gain. It is designed to have an enhanced short wavelength sensitivity, with quantum efficiency of 60 % at 430 nm.

The standard ceramic carrier package allows for easy handling and coupling to scintillating crystals such as LSO and BGO. Combined with the superior short wavelength responsivity, it makes this APD ideal in demanding applications such as Positron Emission Tomography (PET).

The C30626FH and C30703FH series are large area Si APDs in flat pack packages for either direct detection or easy coupling to scintillator crystals.

The C30626 uses a standard reach through structure and has peak detection at about 900 nm. The C30703 is enhanced for blue wavelength response and has peak quantum efficiency at ~ 530 nm. These APDs are packaged in square flat pack with or without windows or on ceramics. The no-window devices can detect direct radiation of X-rays and electrons at the energies listed, and the windowed packages are best for easy scintillator coupling.

Product Table

Large Area Si-APDs – UV-Enhanced APDs

Part Number	Photo Sensitive Diameter	Responsivity	Dark Current	Spectral Noise Current	Capacitance @ 100 KHz	Response Time	NEP	Vop Range
Unit	mm	A/W	nA	pA/√Hz	pF	ns	fW/(Hz)	V
C30626FH	5 x 5	22 (@900 nm)	250	0.5	30	5	23 (@900 nm)	275 - 425
C30703FH	10 x 10	16 (@530 nm)	10	0.7	120	5	40 (@530 nm)	275 - 425
C30739ECERH	5.6 x 5.6	20 (@430 nm)	50	1.4	60	2	-	275 - 425

Graph 1

Quantum Efficiency vs. Wavelength

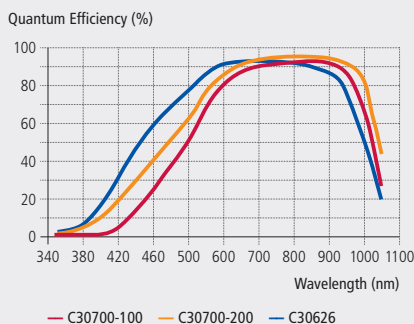

Graph 2

Quantum Efficiency vs. Wavelength

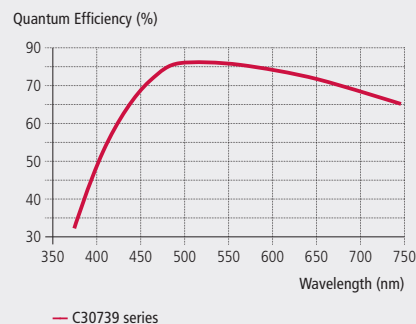

AVALANCHE PHOTODIODES FOR RANGE FINDING APPLICATIONS

PHOTODIODES FOR HIGH-PERFORMANCE APPLICATIONS ■

Right: TO-C30737PH Series
T-1 $\frac{3}{4}$ (TO-like) Through-Hole
Package (4.9 mm Diameter)

Left: C30737LH Series
Leadless Ceramic Carrier
Package (3 x 3 mm²)



C30737 High Speed, Low Voltage APD – C30724 Low Temperature Coefficient APD

Applications

- Laser range finding for 600 to 950 nm range
- Optical communication
- Analytical Instrumentation

Features and Benefits

- Optimized versions for 900 and 800 nm peak sensitivity
- Standard versions with 500 and 230 μ m active diameter
- Various package types: hermetic TO, plastic TO, SMD
- High gain at low bias voltage
- Low breakdown voltage
- Fast response, $t_r \sim 300$ ps
- Low noise, in ~ 0.2 pA/ $\sqrt{\text{Hz}}$
- RoHS compliant

Product Description

The PerkinElmer C30737 series silicon APDs provide high responsivity between 500 nm and 1000 nm, as well as extremely fast rise times at all wavelengths with a frequency response above 1 GHz. The C30724 as a low gain APD can be operated at fixed voltage without the need of a temperature compensation.

Standard versions are available in two active area sizes: 0.23 and 0.5 mm diameter. They are offered in the traditional hermetic TO housing (“E”), in cost effective plastic through-hole T-1 $\frac{3}{4}$ (TO-like, “P”) packages, and in leadless ceramic carrier (LCC, “L”) package for surface mount technology. All listed varieties are ideally suited for high-volume, low cost applications.

Customization of these APDs is offered to meet your design challenges. Operation voltage selection and binning or specific wavelength filtering options are among many of the application specific solutions available.

Product Table

C30737 Epitaxial Silicon APD – C30724 Low Gain APD

Part Number	Package	Optical Bandpass Filter	Active Area Diam.	Peak Sensitivity Wavelength	Breakdown Voltage		Temp. Coeff. Of V_{op} , for Constant M	Gain@ λ_{peak}	Responsivity @ λ_{peak}	Total Dark Current (Bulk + Surface)		Noise Current, (f = 10 kHz, $\Delta f = 1$ Hz)	Capacitance	Rise & Fall Time, (RL = 50 Ω , 10% - 90% - 10% Points)
		design	design	typ	min	max	typ	typ	typ	typ	max	typ	typ	
		nm	μ m	λ_{peak}	V_{BR}	V_{BR}	$V/^\circ\text{C}$	M	M	I_D	I_D	$\text{pA}/\sqrt{\text{Hz}}$	C_D	ns
C30737EH-230-80	TO	-	230	800	120	200	0.5	100	50	2.5	10	0.1	1.0	0.22
C30737PH-230-80	T-1 $\frac{3}{4}$	-	230	800	120	200	0.5	100	50	2.5	10	0.1	1.0	0.22
C30737LH-230-80	LCC	-	230	800	120	200	0.5	100	50	2.5	10	0.1	1.0	0.22
C30737LH-230-81	LCC	635	230	635	120	200	0.5	100	35	2.5	10	0.1	1.0	0.22
C30737EH-500-80	TO	-	500	800	120	200	0.5	100	50	5	20	0.3	2.0	0.30
C30737PH-500-80	T-1 $\frac{3}{4}$	-	500	800	120	200	0.5	100	50	5	20	0.3	2.0	0.30
C30737LH-500-80	LCC	-	500	800	120	200	0.5	100	50	5	20	0.3	2.0	0.30
C30737LH-500-81	LCC	635	500	800	120	200	0.5	100	35	5	20	0.3	2.0	0.30
C30737EH-230-90	TO	-	230	900	180	260	1.3	100	60	2.5	10	0.2	0.6	0.50
C30737PH-230-90	T-1 $\frac{3}{4}$	-	230	900	180	260	1.3	100	60	2.5	10	0.2	0.6	0.50
C30737PH-230-90	LCC	-	230	900	180	260	1.3	100	60	2.5	10	0.2	0.6	0.50
C30737PH-230-92	LCC	905	230	905	180	260	1.3	100	60	2.5	10	0.2	0.6	0.50
C30737EH-500-90	TO	-	500	900	180	260	1.3	100	60	5	20	0.4	1.0	0.60
C30737PH-500-90	T-1 $\frac{3}{4}$	-	500	900	180	260	1.3	100	60	5	20	0.4	1.0	0.60
C30737LH-500-90	LCC	-	500	900	180	260	1.3	100	60	5	20	0.4	1.0	0.60
C30737LH-500-92	LCC	905	500	905	180	260	1.3	100	60	5	20	0.4	1.0	0.60
C30724EH	TO	-	500	920	-	350	-	15	8.5	20	40	0.1	1.0	5
C30724PH	T-1 $\frac{3}{4}$	-	500	920	-	350	-	15	8.5	20	40	0.1	1.0	5

Electrical Characteristics at $T_{Ambient} = 22^\circ\text{C}$; at operating voltage, V_{op}

PIN PHOTO- DIODES FOR INDUSTRIAL APPLICATIONS

InGaAs and Si PIN Diodes – Quadrant Detectors – UV-Enhanced

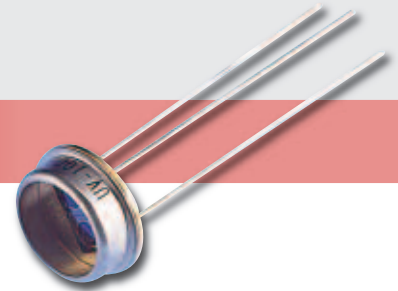

Applications

- Telecom
- Instrumentation
- Photometry
- Laser power monitoring
- Fiber optic test equipment
- High speed switching
- Spot tracking
- Laser range finders
- Missile guidance
- Laser warning system

Features and Benefits

- High speed
- High responsivity
- Hermetically sealed
- Large area available
- High shunt resistance, low dark current

Product Description

Silicon PIN photodiodes are available in a wide variety of active area to accommodate a large variety of applications. The PIN structure allows high quantum efficiency and fast response for detection of photon in the 400 nm to 1100 nm range.

The YAG series offers an exceptional 0.4 A/W at 1060 nm by using a thick silicon material. Designed with a guard ring to collect current generated outside of the active area, they are the detectors of choice when the entire chip is illuminated by reducing unwanted carriers responsible for noise. Precise beam positioning can be achieved by using our quadrant detectors. They are designed with 4 pie-shaped quadrant sections from doping process thus reducing to almost zero the “dead” space between each quadrant. Each quadrant is connected to an isolated lead.

The C30741 provide fast response and good quantum efficiency in the spectral range between 300 nm to 1100 nm. Designed for high-speed, high-volume production and cost sensitive applications, these photodiodes are offered in plastic package, either TO style or SMD packages with a visible blocking filter option.

Our UV series are high quality Si PIN photodiode in hermetically sealed TO package designed for the 220 nm to 1100 nm wavelength region with enhanced operation in the UV range. Low noise detection is achieved by operating the UV series in photovoltaic mode (0V bias).

The InGaAs PIN detectors provide high quantum efficiency from 800 nm to 1700 nm. They feature low capacitance for extended bandwidth, high resistance for high sensitivity, high linearity, and uniformity within 2 % across the detector active area.

Product Table

InGaAs PIN, High Speed, Peak Wavelength at 1550 nm

Unit	Active Diameter µm	Responsivity Peak A/W	Capacitance pF	B _w GHz	Dark Current nA	Breakdown Voltage V	Operating Voltage V	Package
C30616ECERH	50	0.95	0.35	3.5	<1	100	5	Ceramic carrier
C30617BH	100	0.95	0.8	3.5	<1	100	5	TO-18, ball lens
C30617BFCH	100	0.95	0.8	3.5	<1	100	5	TO-18, FC receptacle
C30617BSCH	100	0.95	0.8	3.5	<1	100	5	TO-18, SC receptacle
C30617BSTH	100	0.95	0.8	3.5	<1	100	5	TO-18 ST receptacle
C30617ECERH	100	0.95	0.6	3.5	<1	100	5	Ceramic carrier
C30618BFCH	350	0.95	4	0.75	1	100	5	TO-18, FC receptacle
C30618GH	350	0.95	4	0.75	1	100	5	TO-18
C30618ECERH	350	0.95	4	0.75	1	100	5	Ceramic carrier
C30637ECERH	75	0.95	0.4	3.5	<1	100	5	Ceramic carrier

Product Table

InGaAs PIN, Large Area, Peak Wavelength at 1550 nm

Unit	Active Diameter mm	Responsivity Peak A/W	Capacitance pF	Shunt Resistance Mega Ohm	B _w GHz	Dark Current nA	Breakdown Voltage V	Operating Voltage V	Package
C30641EH-TC	1	0.95	40	50	75	5	80	0-5	TO-8, flange, TE-cooled
C30641EH-DTC	1	0.95	40	50	75	5	80	0-5	TO-8, flange, dual TE
C30641GH	1	0.95	40	50	75	5	80	0-5	TO-18
C30642GH	2	0.95	150	25	20	10	50	0-5	TO-5
C30665GH	3	0.95	200	10	3	25	50	0-5	TO-5
C30723GH	5	0.95	950	5	3	-	50	0-5	TO-5
C30619GH	0.5	0.95	8	250	350	1	80	0-10	TO-18

Product Table

Silicon PIN

Unit	Active Diameter um	Active Area mm ²	Responsivity Peak A/W	Peak Wavelength nm	Capacitance pF	Rise/Fall Time ns	Dark Current nA	Shunt Resistance MΩ	Breakdown Voltage V	Operating Voltage V	Package
C30741PH-15S	1.5x1.5	2.25	800	800	11	2	0.05	-	300	10	Plastic T 1-¾ throughole
C30741PFH-15S	1.5x1.5	2.25	800	800	11	2	0.05	-	300	10	T 1-¾ visible blocking
C30807EH	1	0.8	0.6	900	2.5	5	10	-	>100	45	TO-18
C30808EH	2.5	5	0.6	900	6	8	30	-	>100	45	TO-5
C30822EH	5	20	0.6	900	17	10	50	-	>100	45	TO-8
C30809EH	8	50	0.6	900	35	15	70	-	>100	45	TO-8
C30810EH	11	100	0.6	900	70	20	300	-	>100	45	TO-36
C30971EH	0.5	0.2	0.5	830	1.6	0.5	10	-	>200	100	TO-18
FFD-100H	2.5	5.1	0.6	850	8.5	3.5	5	-	>125	15	TO-5
FFD-200H	5.0	20	0.6	850	30	5	10	-	>125	15	3 pin, 0.6 inch dia.
FND-100QH	2.5	5.1	0.64	920	8.5	<1n	10	-	150	100	TO-5
UV-040BQH	1.0	0.81	0.62	900	25	-	-	>500	-	0	TO-5, response down to 200 nm
UV-100BQH	2.5	5.1	0.62	900	150	-	-	>100	-	0	TO-5, response down to 200 nm
UV-215BGH/340	0.0					-	-	-	-	0	TO-5, response down to 250 nm
UV-215BQH	5.5	23.4	0.62	900	700	-	-	>50	-	0	TO-5, response down to 200 nm
UV-245BGH	5	18.5	0.62	900	630	-	-	>75	-	0	TO-5, response down to 250 nm
UV-245BQH	5	18.5	0.62	900	630	-	-	>75	-	0	TO-5, response down to 200 nm
YAG-100AH	2.5	5.1	0.7	1000	2.5	5	<20	-	>200	180	TO-5
YAG-200H	5.0	20	0.7	1000	6	5	<100	-	>200	180	TO-8
YAG-444AH	16.0	200	0.7	1000	35	5	<200	-	>200	180	TO-36
SR10BP		0.65		900	10	10	10		170		SMT
SR10BP-B		0.65		900	10	10	10		170		SMT
SR10DE		0.56 x 0.56			4	150	10		170		SMT
SR10DE-B		6.71			4	150	10		170		SMT
PFD10		0.31	0.6	880	25	200	5		170		SMT
CR50DE			0.5	880	2.5	3000	0.5		50		

Product Table

Specialty Silicon Detectors

Unit	Description	Active Diameter mm	Active Area mm ²	Capacitance pF	Rise/Fall Time ns	Dark Current nA	Breakdown Voltage min V	Responsivity 900 nm A/W	Responsivity 1060 nm A/W	Noise Current pA/sqrt(Hz)	Package
C30845EH	Quadrant PIN	8	50	8/q	6	70 nA	100	0.6	0.17	0.26/q	TO-8
YAG-444-4AH	Quadrant PIN	11.3	100	9/q	8	<75 nA	100	0.6	0.5	0.2/q	Custom
DTC-140H	Dual wavelength detector Si-Si (Top/Bottom)	3.5	9.9	300/300	-	50/50 MΩ	-	0.6/0	0.25/0.15	0.033/0.133	Custom

OPTOELECTRONIC COMPONENTS FOR SMOKE DETECTOR APPLICATIONS

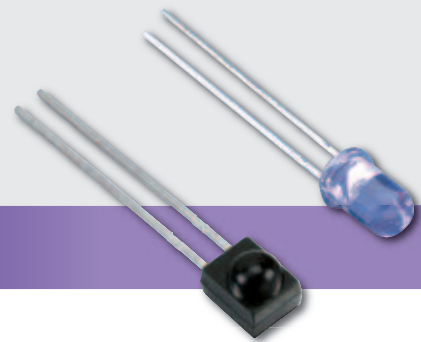

Selected Photodiodes and Infrared Emitting Diodes (IREDS)

Applications

- Electro-optical smoke detection

Features and Benefits

- High quality components: photodiodes, IREDS (UL- listed)
- Binning for optimized transfer function
- Customized optical block (PD+IRED) assemblies
- Smoke chamber assemblies according specified transfer function

Product Description

An electro-optical smoke detector consists of an Infrared LED (IRED) and Photodiode (PD) assembly, which exhibits a signal under the presence of smoke in the detection volume (smoke chamber). Signal range under smoke and clean-air conditions and their long term stability are key features of a smoke detector module. PerkinElmer offers IRED and PD components as well as customized assemblies with specified signal level range. Such an assembly can be an optical block containing an IRED and PD for (SMD) board soldering or the complete smoke chamber, which are produced in high-volumes. Please contact PerkinElmer to discuss your requirements.

Product Table

Selected Photodiodes Used in Smoke Detection Applications

Symbol	Package	Active Area	Short Circuit Current	Dark Current	Junction Capacitance	Radiometric Sensitivity @ λ_P	Spectral Range	Peak Wavelength	Noise Equivalent Power
			min	max	typ	typ		λ_P	typ
Unit		mm	I_{sc}	I_o	C_j	S_R	λ_{RANGE}	nm	NEP
			μA	nA	nF	A/W	nm	nm	W/√Hz
VTP7840H	Lensed sideloooker IRT	5.27	50	20	40	0.55	725-1150	925	5.3 x 10-14
VTP413H	Lensed sideloooker	7.45	120 (typ)	30	50	0.55	400-1150	925	2.3 x 10-14
VTP100H	Flat sideloooker IRT	7.45	35	30	50	0.5	725-1150	925	2.5 x 10-14
VTP1188SH	Lensed ceramic	11	200 (typ)	30	300	0.55	400-1100	925	-

Product Table

Selected Infrared LEDs (IREDS) Used in Smoke Detection Applications

Symbol	Package	Total Power	Test Current	Forward Drop Voltage	Half Power Beam Angle
		typ	typ	@ I_{FT}	typ
Unit		P_o	I_{FT}	V_F	$\Theta_{1/2}$
		mW	mA (pulsed)	V	degree
VTE1291-1H	T-1 3/4 lensed	20	100	1.5	±12
VTE1291-2H	T-1 3/4 lensed	25	100	1.5	±12
VTE1295	T-1 3/4 lensed	20	100	1.5	±8

Left: Spectrally Adapted Photodiodes and Phototransistors

Right: C30737PH Series T-1 ¼ (TO-like) Through-Hole Package (4.9 mm Diameter)

AMBIENT LIGHT SENSORS

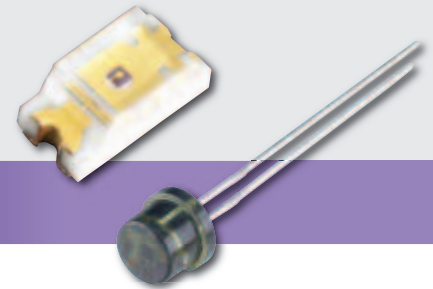

Spectrally Adapted Photodiodes and Phototransistors

Applications

- Interior and exterior light switching (dusk/dawn switch)
- Interior and exterior light control (dimming)
- Automotive headlight dimmer
- Display contrast control
- Energy conservation
- Oil burner flame monitoring

Features and Benefits

- Response approaching human eye using PerkinElmer's IR-BLOC™ technology
- Perfect light sensor in conjunction with PerkinElmer pyroelectric detectors for motion controlled light switches
- RoHS compliant
- Selectable wavelength detection range
- Small footprint
- Surface mount packages

Product Description

Ambient light sensors from PerkinElmer provide an easy solution for applications that require a response similar to the human eye, making it ideal when the response should only be influenced by visible light. These devices contribute in various applications to energy conservation in both fixed and portable devices. There are three main device types, one being filtered photodiodes, the second filtered phototransistors and finally wavelength selective devices based on III-V material. They are available in a number of standard packages, including surface mount for automated assembly.

Product Table

Spectrally Adapted Photodiodes and Phototransistors

Symbol	Package	Active Area	Short Circuit Current @ H = 100fc, 2850 K		Dark Current		Junction Capacitance		Radio-metric Sensitivity @ λ _P	Spectral Range	Peak Wavelength
			min	I _{sc}	typ	max	typ	max	typ		
			μA	nA	nA	nA	pF	pF	A/W	λ _{RANGE}	λ _P
VTP1220FBH	T-1 ¼ flat	1.219	0.7	-	10	-	18	0.27	400-700	550	
VTP9812FH	T-1 ¼ flat	1.548	0.7	-	10	-	18	0.034	400-700	580	
VTT9812FH	T-1 ¼ flat	0.192	100	-	100	-	-	7	450-700	585	
SR10SPD 470-0.9	SMT	0.70	-	-	0.03	150	-	0.18	380-556	470	
SR10SPD 525-0.9	SMT	0.73	-	-	0.03	100	-	0.25	480-560	525	

Electrical characteristics at T_{Ambient} = 25 °C

Graph 1

Responsivity @ 25° C VTT9812FH IR-BLOC™

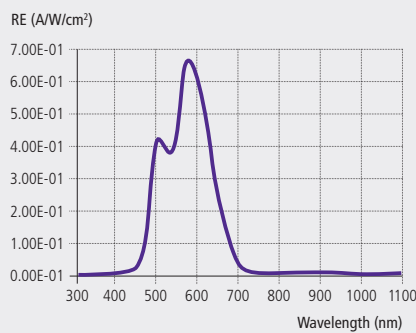

Graph 2

VTT9812FH Output Versus Low Light Levels

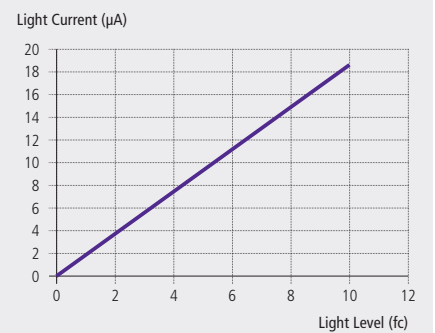

FAST RESPONSE SILICON PHOTODIODES FOR INDUSTRIAL AND COMMERCIAL APPLICATIONS

Silicon Photodiodes – VTP Series

Applications

- Smoke detection
- Barcode scanning
- Light meters
- Pulse oximeters

Features and Benefits

- Visible to IR spectral range
- Integral visible rejection filters available
- 1 to 2 % linearity over 7 to 9 decades
- Low dark currents
- High shunt resistance
- Low capacitance



Product Description

Photodiodes in this series have been designed for low junction capacitance. The lower the capacitance, the faster the response of the photodiode when the RC time constant is your limiting factor. Also, speed can be further increased by reverse biasing the photodiodes. These devices have excellent response in the IR region and are well matched to IR LEDs (VTE series). Some photodiodes are available in packages which incorporate a visible rejection filter, effectively blocking light below 700 nm. Photodiodes made with the VTP process are suitable for operation under reverse bias conditions but may be used in the photovoltaic mode. Typical reverse breakdown voltages are around 140 V. Low dark currents under reverse bias are also a feature of this series.

Product Table

Silicon Photodiodes – VTP Series

Symbol	Package	Active Area mm ²	Short Circuit Current	Dark Current	Junction Capacitance	Radiometric Sensitivity @ λ _p	Spectral Range nm	Peak Wavelength	Active Area
			min I _{sc} μA	max I _d nA	max C _j pF	typ S _R A/W		λ _p nm	typ NEP W/√Hz
VTP100H	Flat sideloooker IRT	7.45	35	30	50	0.5	725 - 1150	925	2.5 x 10 ⁻¹⁴
VTP100CH	Flat sideloooker	7.45	50	30	50	0.55	400 - 1150	925	9.0 x 10 ⁻¹⁴
VTP1012H	TO-46	1.6	10	7	6	0.55	400 - 1150	925	8.7 x 10 ⁻¹⁴
VTP1112H	TO-46 lensed	1.6	30	7	6	0.55	400 - 1150	925	8.7 x 10 ⁻¹⁴
VTP1188SH	Lensed ceramic	11	200 (typ)	30	300	0.55	400 - 1100	925	-
VTP1220FBH	T-1¾ flat	1.219	0.7	10	18	0.27	400 - 725	550	-
VTP1232H	T-1¾	2.326	100	25	180	0.6	400 - 1100	920	-
VTP1232FH	T-1¾ flat	2.326	21	25	180	0.6	400 - 1100	920	-
VTP1332H	T-1¾ IRT	2.326	75	25	180	0.55	725 - 1150	920	-
VTP1332FH	T-1¾ flat IRT	2.326	17	25	180	0.55	725 - 1150	920	-
VTP3310LAH	T1	0.684	24	35	25	0.55	400 - 1150	925	1.9 x 10 ⁻¹³
VTP3410LAH	T1 IRT	0.684	15	35	25	0.55	700 - 1150	925	1.9 x 10 ⁻¹³

Electrical characteristics at T_{Ambient} = 25 °C

Silicon Photodiodes – VTP Series

Symbol	Package	Active Area	Short Circuit Current		Dark Current	Junction Capacitance	Radiometric Sensitivity @ λ_P	Spectral Range	Peak Wavelength	Active Area
			min	max	max	typ			typ	
Unit		mm ²	I _{SC}	I _D	C _J	S _R	λ_{RANGE}	λ_P	NEP	
			μA	nA	pF	A/W	nm	nm	W/√Hz	
VTP413H	Lensed sideloooker	7.45	120 (typ)	30	50	0.55	400-1150	925	2.3×10^{-14}	
VTP4085H	Ceramic	21	200 (typ)	100	500	0.55	400-1100	925	-	
VTP4085SH	Ceramic	21	200 (typ)	50	500	0.55	400-1100	925	-	
VTP5050H	TO-5	7.45	40	18	24	0.55	400-1150	925	1.4×10^{-13}	
VTP6060H	TO-8	20.6	120	35	60	0.55	400-1150	925	1.9×10^{-13}	
VTP7110H	Lateral	0.684	6	35	25	0.55	400-1150	925	1.9×10^{-13}	
VTP7210H	Lateral IRT	0.684	5	35	25	0.55	700-1150	925	1.9×10^{-13}	
VTP7840H	Lensed sideloooker IRT	5.27	50	20	40	0.55	725-1150	925	5.3×10^{-14}	
VTP8350H	Ceramic	7.45	65	30	50	0.55	400-1150	925	1.8×10^{-13}	
VTP8440H	8 mm ceramic	5.16	30	15	15	0.55	400-1150	925	1.3×10^{-13}	
VTP8551H	Mini-DIP	7.45	50	30	50	0.55	400-1150	925	1.8×10^{-13}	
VTP8651H	Mini-DIP IRT	7.45	35	30	50	0.5	725-1150	925	2.0×10^{-13}	
VTP8740_TRH	SMT clear plastic	5.269	75	20	50	0.6	400-1150	925	2.0×10^{-13}	
VTP8840_TRH	SMT IRT	5.269	50	20	50	0.6	725-1150	925	2.0×10^{-13}	
VTP9412H	6 mm ceramic	1.6	10	7	6	0.55	400-1150	925	8.7×10^{-14}	
VTP9812FH	T-1¾ flat	1.548	0.7	10	18	0.034	400-700	580	-	
SR10SPD 880-0.9	SMT	0.73	-	0.01	-	-	820-935	890	-	

Electrical characteristics at T_{Ambient} = 25 °C

Graph 1

Absolute Spectral Response*

Radiometric Sensitivity, A/W

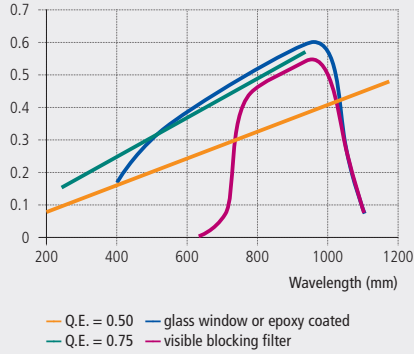

Graph 2

Rise/Fall Times – Non Saturated*

Response Time (μsec 10–90 %)

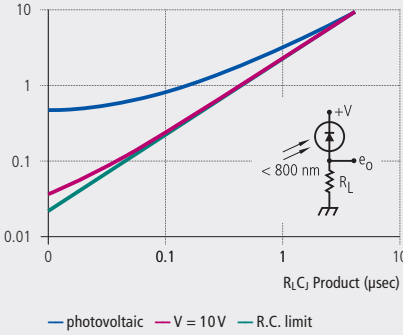

Graph 3

Relative Dark Current vs. Temperature*

Relative Dark Current

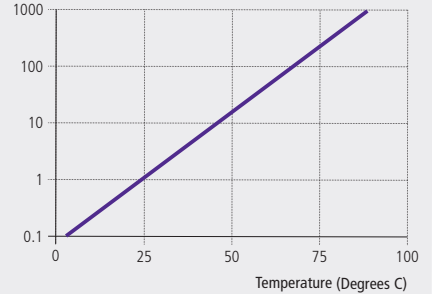

Graph 4

Rel. Junction Capacitance vs. Voltage*

Relative Capacitance

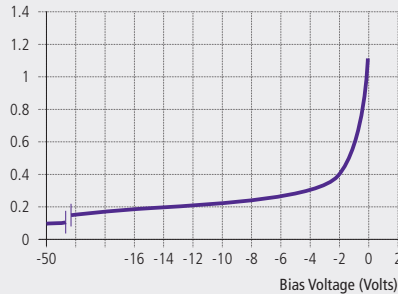

Graph 5

Temp. Coefficient of Light Current vs. Wavelength*

Temperature Coefficient (%) / Degree (C)

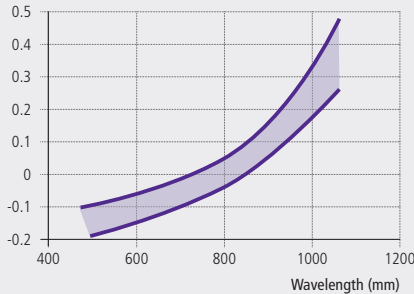

Graph 6

Rel. Short Circuit Current vs. Illumination*

Relative Short Circuit Current

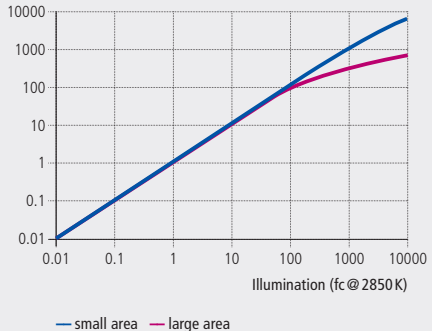

* typical characteristic curves @ 25 °C (unless otherwise noted)

INDUSTRY STANDARD SILICON PHOTODIODES



Silicon Photodiodes – VTD Series

Applications

- Pulse oximetry
- Automotive
- Surface mount assembly process

Features and Benefits

- Alternate source for industry standard photodiodes
- Surface mount package available
- Available in package with integrated IR filtering
- Large area PIN available on ceramic package
- RoHs compliant

Product Description

The VTD series are photodiodes which have been used in many applications as replacement for competitive devices.

Product Table

Silicon Photodiodes – VTD Series

Symbol	Industry Equivalent	Package	Active Area	Short Circuit Current		Dark Current	Junction Capacitance	Radiometric Sensitivity @ λ_P	Spectral Range	Peak Wavelength	Noise Equivalent Power
				min	max						
Unit			mm ²	I _{sc}	I _d	C _j	S _R	λ_{RANGE}	λ_P	NEP	
				μA	nA	nF	A/W	nm	nm	W/Hz	
VTD31AAH	CLD31AA	Ceramic	16.73	150 @ 5 mW/cm ² , 2850 K	50	0.50	0.55	400-1150	860	-	
VTD34H	BPW34	Mini dip	7.45	50 @ 1000 Lux, 2850 K	30	0.060	0.60	400-1100	900	4.8 x 10 ⁻¹⁴	
VTD34FH	BPW34F	Mini dip	7.45	15 @ 0.5 mW/cm ² , 940 nm	30	0.060	0.60	725-1150	940	4.8 x 10 ⁻¹⁴	
VTD34SMH	BPW34	SMT	7.45	50 @ 1000 Lux, 2850 K	30	0.025	0.60	400-1100	900	4.8 x 10 ⁻¹⁴	
VTD34FSMH	BPW34F	SMT	7.45	15 @ 0.5 mW/cm ² , 940 nm	30	0.080	0.60	725-1150	940	4.8 x 10 ⁻¹⁴	
VTD205H	SFH205	TO-92	7.41	15 @ 0.5 mW/cm ² , 940 nm	30	0.072	0.60	800-1100	925	-	
VTD205KH	SFH205K	TO-92	7.41	50 @ 1000Lux, 2850 K	30	0.072	0.60	400-1100	925	-	
VTD206H	SFH206	TO-92	7.41	15 @ 0.5 mW/cm ² , 940 nm	30	0.072	0.60	750-1100	925	-	
VTD206KH	SFH206K	TO-92	7.41	50 @ 1000Lux, 2850 K	30	0.072	0.60	400-1100	925	-	
VTH2090H	S1723-04	Black ceramic	84.64	65 @ 100 Lux	10	0.070	0.60	400-1100	960	-	

Figure 1

Package Drawing – VTD Series – Mini Dip Package

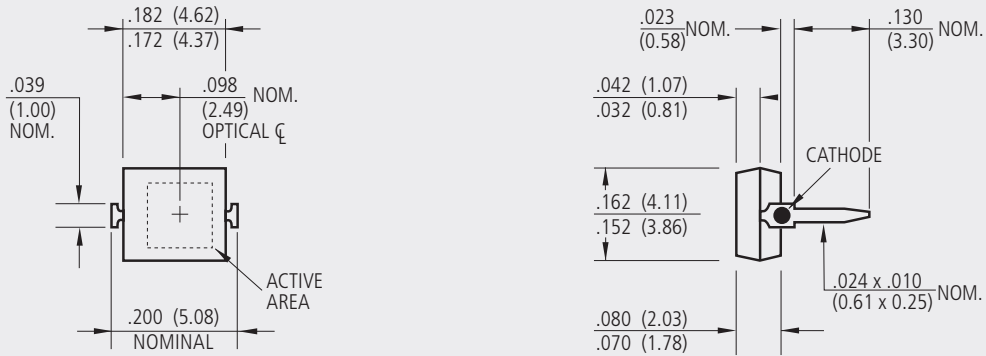

Figure 2

Package Drawing – VTD Series – SMT Package

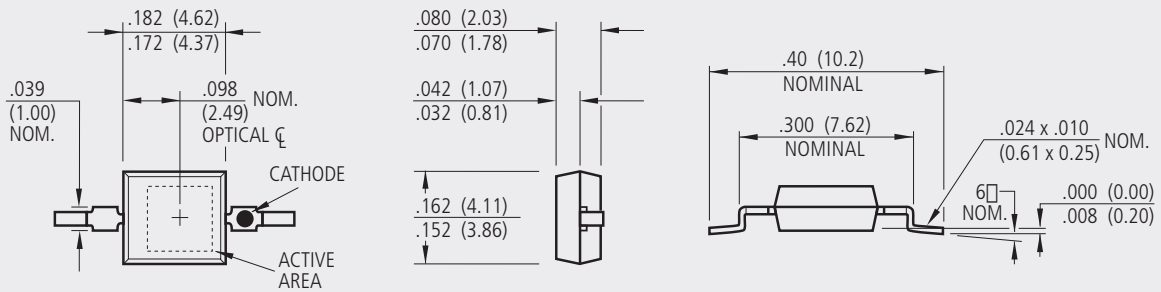
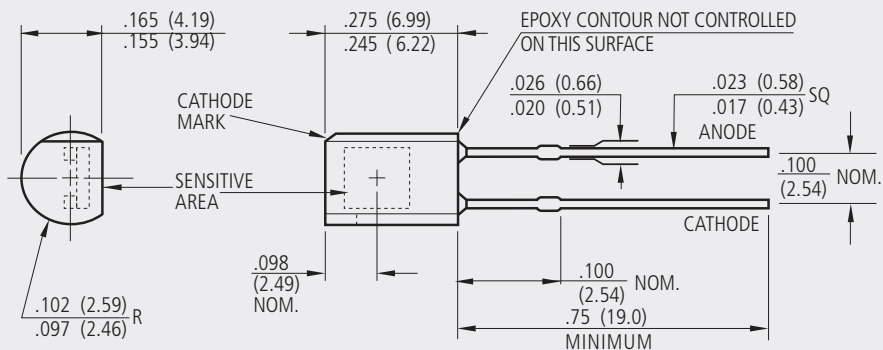

Figure 3

Package Drawing – VTD Series – TO-92 Package



BLUE-ENHANCED SILICON PHOTODIODES FOR INDUSTRIAL AND COMMERCIAL APPLICATIONS

Silicon Photodiodes – VTB Series – Ultra High Dark Resistance

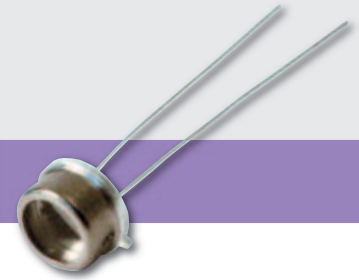

Applications

- Ambient light sensing
- UV and blue light sensing
- Flame monitoring
- Light meters
- Photometry

Features and Benefits

- UV to IR spectral range
- Integral IR rejection filters available
- Response @ 365 nm, 0.14 A/W typical
- Response @ 220 nm, 0.06 A/W typical with UV window
- 1 to 2 % linearity over 7 to 9 decades
- Very low dark current
- High shunt resistance
- RoHs compliant

Product Description

This series of P on N silicon planar photodiodes have been designed for optimum response through the visible part of the spectrum. Units with UV transmitting windows also exhibit excellent response in the UV. “B” series units have a built-in infrared rejection filter for applications requiring a response approximating the human eye. Photodiodes made with the VTB process are primarily intended to be used in photovoltaic mode but may be used with a small reverse bias. All photodiodes in this series exhibit very high shunt resistance. This characteristic leads to very low offsets when used in high gain trans-impedance op-amps circuits.

VTB1012



Small area planar silicon photodiode in flat window TO-46 package

VTB6061



Large area planar silicon photodiode in a flat window TO-8 package

VTB4051



Planar silicon photodiode mounted on a ceramic substrate and coated with a layer of clear epoxy

VTB8341



Planar silicon photodiode mounted on a ceramic substrate and coated with a layer of clear epoxy

Silicon Photodiodes – VTB Series – Ultra High Dark Resistance

Symbol	Package	Active Area	Short Circuit Current @ 100 fc, 2850 K		Dark Current		Junction Capacitance	Radiometric Sensitivity @ 365 nm	Spectral Range	Peak Wavelength	Noise Equivalent Power
			min	max	typ	typ	typ	typ	typ	typ	
			I_{sc}	I_D	C_J	S_R	λ_{RANGE}	λ_P	NEP		
Unit		mm ²	μA	nA	nF	A/W	nm	nm	W/ \sqrt{Hz}		
VTB100AH	Flat sidelooper	7.1	50	0.50	0.10	0.55 @ 925 nm	400-1150	925	9.0×10^{-14}		
VTB1012H	TO-46	1.6	8.0	0.10	0.31	0.09	320-1100	920	3.0×10^{-14}		
VTB1012BH	TO-46	1.6	0.80	0.10	0.31	0.28 @ 540 nm	330-720	580	5.3×10^{-14}		
VTB1013H	TO-46	1.6	8.0	0.02	0.31	0.09	320-1100	920	5.9×10^{-15}		
VTB1013BH	TO-46	1.6	0.80	0.02	0.31	0.28 @ 540 nm	330-720	580	1.1×10^{-14}		
VTB1112H	TO-46 lensed	1.6	30.0	0.10	0.31	0.19	320-1100	920	3.0×10^{-14}		
VTB1112BH	TO-46 lensed	1.6	3.0	0.10	0.31	0.28 @ 540 nm	330-720	580	5.3×10^{-14}		
VTB1113H	TO-46 lensed	1.6	30.0	0.02	0.31	0.19	320-1100	920	5.9×10^{-15}		
VTB1113BH	TO-46 lensed	1.6	3.0	0.02	0.31	0.28 @ 540 nm	330-720	580	1.1×10^{-14}		
VTB4051H	Ceramic	14.8	100	0.25	3.0	0.10	320-1100	920	2.1×10^{-14}		
VTB5051H	TO-5	14.8	85	0.25	3.0	0.10	320-1100	920	2.1×10^{-14}		
VTB5051BH	TO-5	14.8	8	0.25	3.0	0.28 @ 540 nm	330-720	580	3.7×10^{-14}		
VTB5051JH	TO-5 with 3 pins	14.8	85	0.25	3.0	0.10	320-1100	920	2.1×10^{-14}		
VTB5051UVH	TO-5	14.8	85	0.25	3.0	0.038 @ 220 nm	200-1100	920	2.1×10^{-14}		
VTB5051UVJH	TO-5 with 3 pins	14.8	85	0.25	3.0	0.038 @ 220 nm	200-1100	920	2.1×10^{-14}		
VTB6061H	TO-5	37.7	260	2.0	8.0	0.10	320-1100	920	5.7×10^{-14}		
VTB6061BH	TO-5	37.7	26	2.0	8.0	0.28 @ 540 nm	330-720	580	1.0×10^{-13}		
VTB6060CIEH	TO-5	37.7		2.0	8.0		460-675	555	1.0×10^{-13}		
VTB6061JH	TO-5 with 3 pins	37.7	260	2.0	8.0	0.10	320-1100	920	5.7×10^{-14}		
VTB6061UVH	TO-5	37.7	260	2.0	8.0	0.04 @ 220 nm	200-1100	920	5.7×10^{-14}		
VTB6061UVJH	TO-5 with 3 pins	37.7	260	2.0	8.0	0.04 @ 220 nm	200-1100	920	5.7×10^{-14}		
VTB8341H	Ceramic	5.16	35	0.10	1.0	0.10	320-1100	920	2.4×10^{-14}		
VTB8440H	8 mm ceramic	5.16	35	2.0	1.0	0.10	320-1100	920	5.9×10^{-14}		
VTB8440BH	8 mm ceramic	5.16	4	2.0	1.0	0.28 @ 540 nm	330-720	580	1.1×10^{-13}		
VTB8441H	8 mm ceramic	5.16	35	0.10	1.0	0.10	320-1100	920	1.3×10^{-14}		
VTB8441BH	8 mm ceramic	5.16	4	0.10	1.0	0.28 @ 540 nm	330-720	580	2.4×10^{-14}		
VTB9412H	6 mm ceramic	1.6	8	0.10	0.31	0.09	320-1100	920	3.0×10^{-14}		
VTB9412BH	6 mm ceramic	1.6	0.8	0.10	0.31	0.28 @ 540 nm	330-720	580	5.3×10^{-14}		
VTB9413H	6 mm ceramic	1.6	8	0.02	0.31	0.09	320-1100	920	5.9×10^{-15}		
VTB9413BH	6 mm ceramic	1.6	0.8	0.02	0.31	0.28 @ 540 nm	330-720	580	1.1×10^{-14}		

Figure 1

Package Drawing – VTB Series – Flat Sidelooper Package

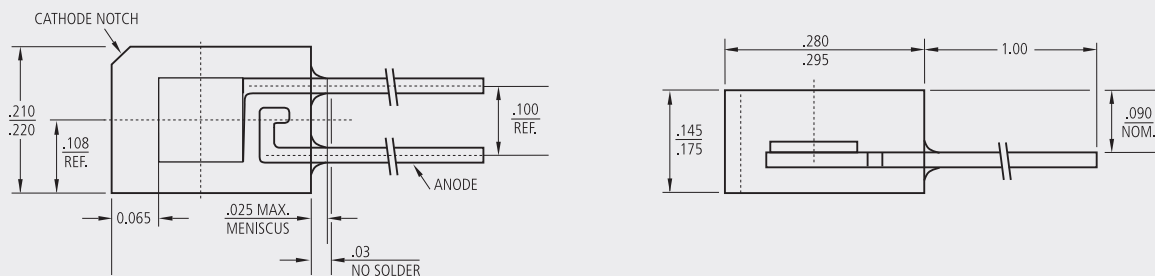

Figure 2

Package Drawing – VTB Series – TO-46 Package

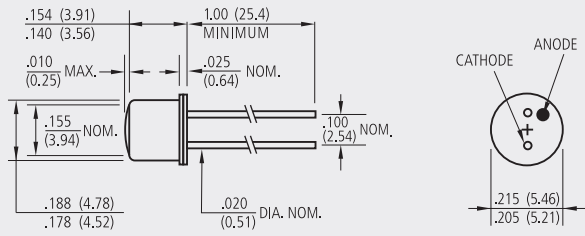

Figure 3

Package Drawing – VTB Series – TO-5 Package

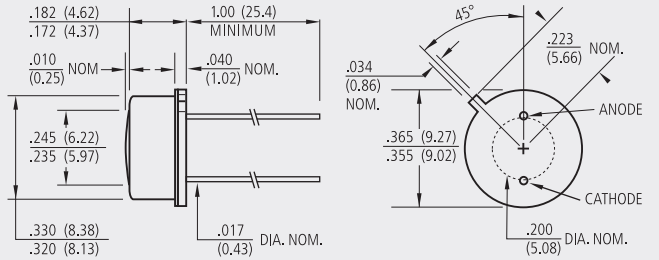

Figure 4

Package Drawing – VTB Series – 8mm Ceramic Package

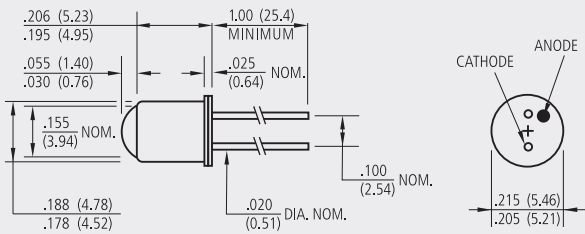

Figure 5

Package Drawing – VTB Series – TO-46 Lensed

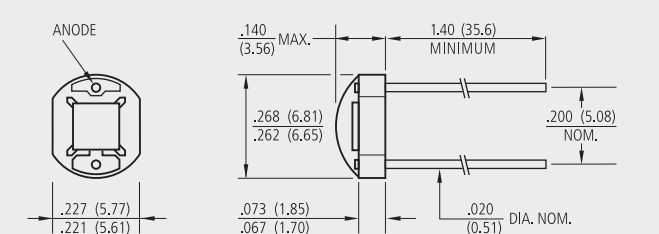

Figure 6

Package Drawing – VTB Series – Ceramic Package

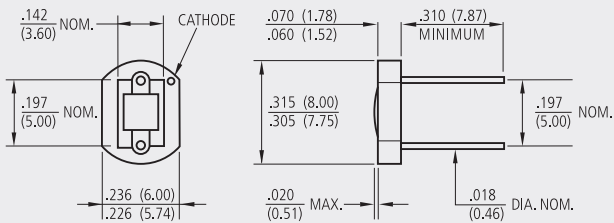
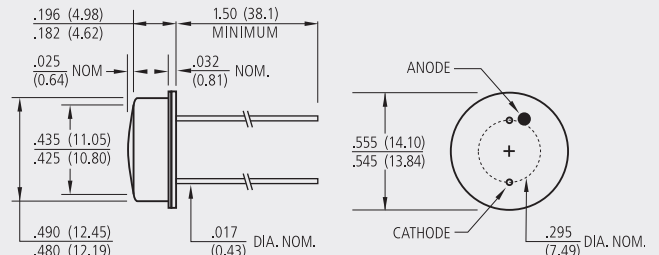

Figure 7

Package Drawing – VTB Series – TO-8 Package



Graph 1

Absolute Spectral Response

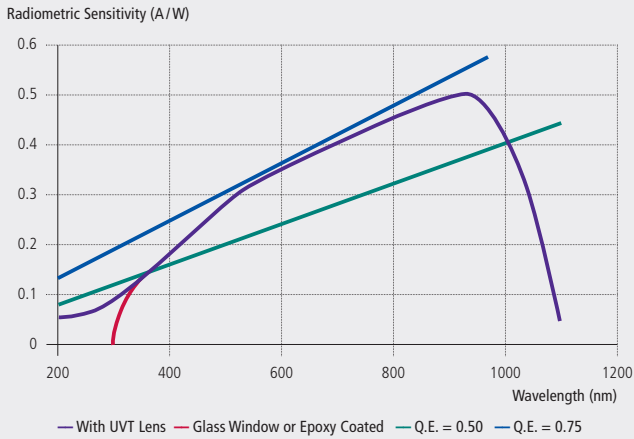

Graph 2

Absolute Spectral Response "B" Series (Filtered)

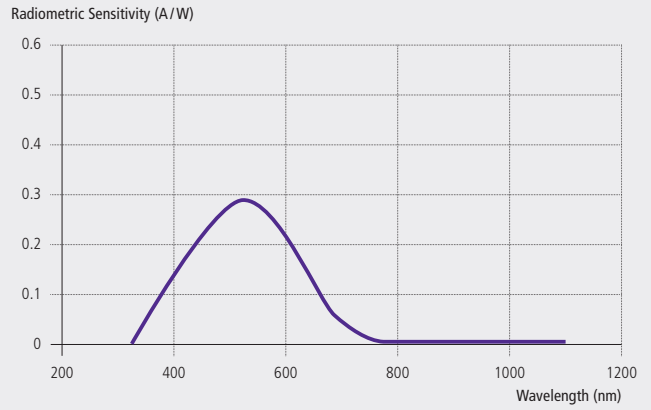

Graph 3

Rel. Current or Resistance vs. Temperature (Referred to 25°C)

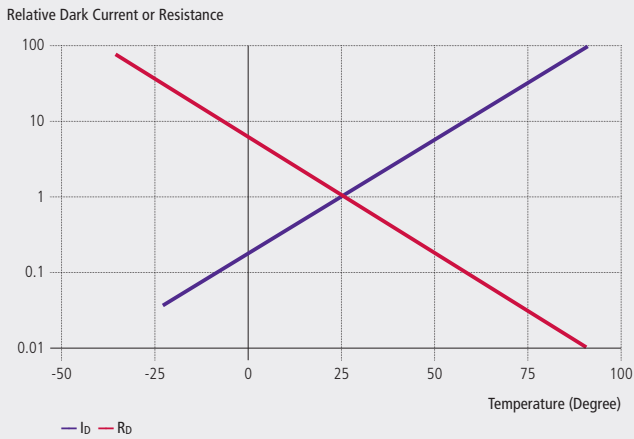

Graph 4

Relative Junction Capacitance vs. Voltage (Referred to Zero Bias)

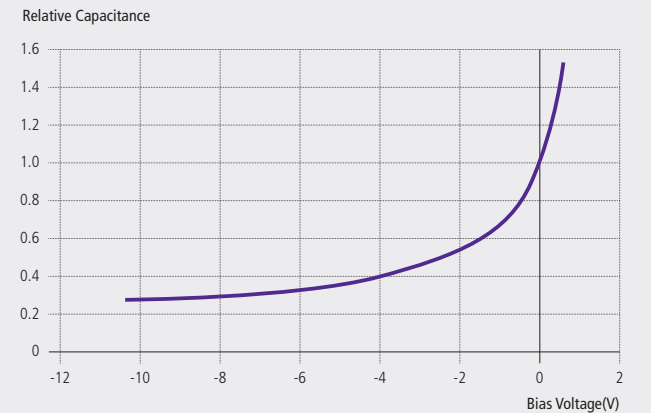

Graph 5

Relative Short Circuit Current vs. Illumination

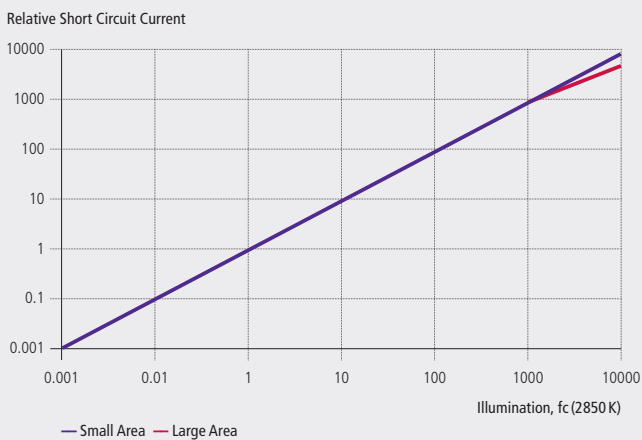

Graph 6

Rise/Fall Times – Non Standard

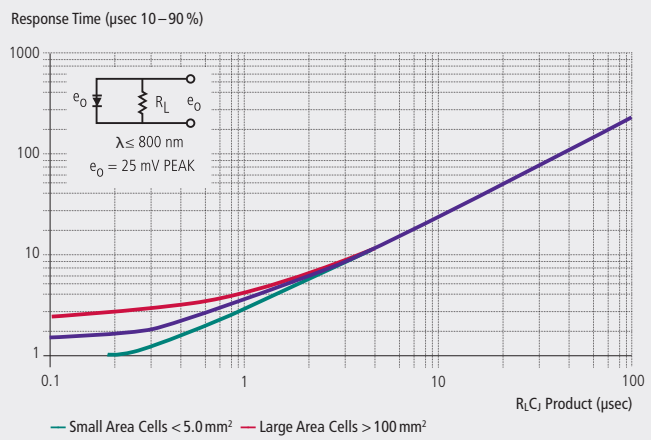

PHOTO-TRANSISTORS FOR INDUSTRIAL AND COMMERCIAL APPLICATIONS



Phototransistors – VTT Series – CR Series

Applications

- Coin counters
- Position sensors
- Remote controllers
- Ambient light sensing
- Street light switching
- Oil burner flame monitoring
- Safety shields
- Margin control-printers
- Monitor paper position and stack height

Features and Benefits

- Low cost visible and near IR photo detection
- Low dark current
- Available in package with integrated visible filtering
- Available in package with integrated IR filtering
- Available in a wide range of packages
- RoHs compliant

Product Description

Phototransistors are photodiode-amplifier combinations integrated within a single silicon chip. The phototransistor can be viewed as a photodiode whose output current is fed into the base of a conventional transistor.

These photodiode-amplifier combinations are put together to overcome the major limitation of photodiodes: unity gain. The typical gain of a phototransistor can range from 100 to over 1500. Many applications demand a greater output than can be generated by a photodiode alone. Even though the signal of a photodiode can be amplified through external circuitry (operational amplifier for example) this is not always cost effective. In such cases, phototransistors provide a lower cost alternative.

CR50TE



- Surface mounting device
- Solid state ceramic chip
- High thermal conductivity
- Special type (CR50TE-DLF) with daylight filter on request

Figure 1

Package Drawing – VTT Series – T-1 $\frac{3}{4}$ Package

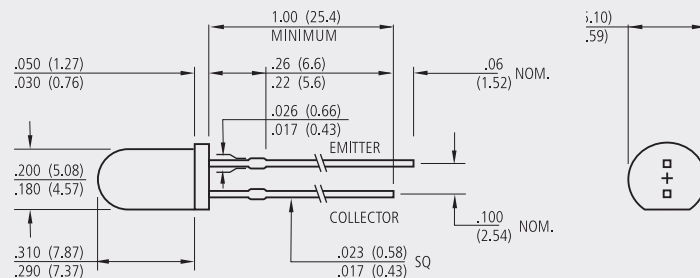

Phototransistors – VTT Series – CR Series

Symbol	Package	Exposed Active Area	Light Current @ 100 fc, V _{CE} = 5 V		Dark Current @ V _{CE} = 10 V		Collector Breakdown @ I _C = 100 μA, 0 fc	Emitter Breakdown @ I _C = 100 μA, 0 fc	Saturation Voltage @ I _C = 100 μA, 100 fc	Rise/Fall Time I _C = 1.0 mA RL = 100 Ω	Angular Response	Spectral Range
			min	max	min	max	V _{BR(CEO)}	V _{BR(CEO)}	V _{CE(SAT)}	Typical	Typical	λ _{RANGE}
Unit		mm ²	I _C mA	I _{CE} nA	V _{BR(CEO)} V	V _{BR(CEO)} V	V _{CE(SAT)} V	t _r /t _f μs	Θ _{1/2} °	nm		
VTT1222WH	T-1¾	0.19	1.9	10 @ VCE = 20V	50	6.0	0.25	2.0	±40	400-1050		
VTT1223WH	T-1¾	0.19	1.5	10 @ VCE = 20V	40	6.0	0.25	3.0	±40	400-1050		
VTT1225H	T-1¾	0.19	4.0	100	30	5.0	0.25	1.5	±5	400-1050		
VTT1226H	T-1¾	0.19	7.5	100	30	5.0	0.25	3.0	±5	400-1050		
VTT1227H	T-1¾	0.19	12.0	100	30	5.0	0.25	4.0	±5	400-1050		
VTT3122EH	Coax hermetic	0.19	1.2	100 @ VCE = 20V	40	6.0	0.25	2.5	±8	400-1050		
VTT3123EH	Coax hermetic	0.19	4.0	100	30	4.0	0.25	4.0	±8	400-1050		
VTT3323LAH	Long T-1	0.19	2.0 @ 20 fc	100	30	5.0	0.25	3.0	±10	400-1050		
VTT3324LAH	Long T-1	0.19	4.0 @ 20 fc	100	30	5.0	0.25	4.0	±10	400-1050		
VTT3325LAH	Long T-1	0.19	6.0 @ 20 fc	100	30	5.0	0.25	5.0	±10	400-1050		
VTT3423LAH	Long T-1	0.19	1.0 @ 20 fc	100	30	5.0	0.25	3.0	±10	700-1050		
VTT3424LAH	Long T-1	0.19	2.0 @ 20 fc	100	30	5.0	0.25	4.0	±10	700-1050		
VTT3425LAH	Long T-1	0.19	3.0 @ 20 fc	100	30	5.0	0.25	5.0	±10	700-1050		
VTT7122H	Lateral	0.19	1.0	100	30	5.0	0.25	2.0	±36	400-1050		
VTT7123H	Lateral	0.19	2.0	100	30	5.0	0.25	2.0	±36	400-1050		
VTT7125H	Lateral	0.19	4.5	100	30	5.0	0.25	2.0	±36	400-1050		
VTT7222H	Lateral	0.19	0.9	100	30	5.0	0.25	2.0	±36	700-1050		
VTT7223H	Lateral	0.19	1.8	100	30	5.0	0.25	2.0	±36	700-1050		
VTT7225H	Lateral	0.19	4.0	100	30	5.0	0.25	4.0	±36	700-1050		
VTT1212H	T-1¾	0.63	2.0 @ 20 fc	100	30	5.0	0.25	4.0	±10	400-1050		
VTT1214H	T-1¾	0.63	4.0 @ 20 fc	100	30	5.0	0.25	6.0	±10	400-1050		
VTT9002H	TO-106 flat	0.63	2.0	100	30	6.0	0.55	4.0	±50	400-1050		
VTT9003H	TO-106 flat	0.63	5.0	100	30	6.0	0.55	6.0	±50	400-1050		
VTT9102H	TO-106 lensed	0.63	6.0	100 @ VCE = 5V	30	4.0	0.55	6.0	±42	400-1050		
VTT9103H	TO-106 lensed	0.63	13.0	100 @ VCE = 5V	30	4.0	0.55	10.0	±42	400-1050		
VTT1015H	TO-46		0.4	25 @ VCE = 20V	40	6.0	0.40	5.0	±35	400-1050		
VTT1016H	TO-46		1.0	25 @ VCE = 20V	30	6.0	0.40	5.0	±35	400-1050		
VTT1017H	TO-46		2.5	25	20	4.0	0.40	8.0	±35	400-1050		
VTT1115H	TO-46 lensed		1.0 @ 20 fc	100	30	6.0	0.40	5.0	±15	400-1050		
VTT1116H	TO-46 lensed		2.0 @ 20 fc	100	30	4.0	0.40	8.0	±15	400-1050		
VTT1117H	TO-46 lensed		4.0 @ 20 fc	100	30	4.0	0.40	8.0	±15	400-1050		
VTT9812FH	T-1¾ flat	0.19	0.10	100	30	5.0	0.25	1.5	±56	450-700		
CR50TE	Ceramic SMD (A2)	0.18		400 @ VCE = 20V	40		0.3 @ I _C = 2 mA	4.0 @ RL = 50 Ω	Wide viewing angle	400-1070		

Figure 2

Package Drawing – VTT Series – T-1 Package

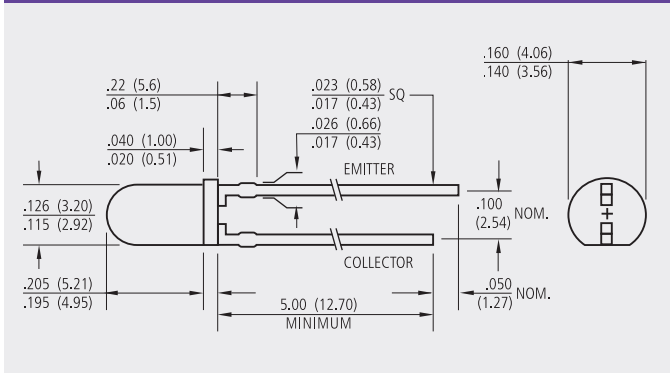
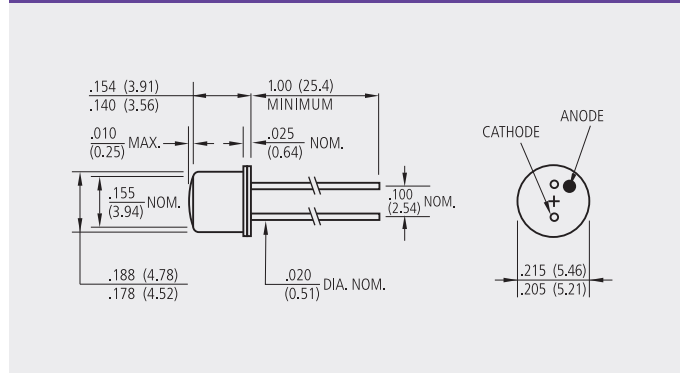

Figure 3

Package Drawing – VTT Series – TO-46 Package



Graph 1

Rel. Spectral Response (Referred to Peak Response of Clear Case)

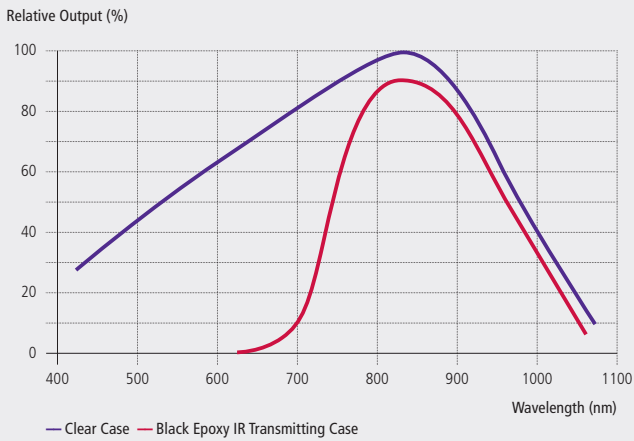

Graph 2

Relative Output vs. Illumination (Normalized at 100 fc)

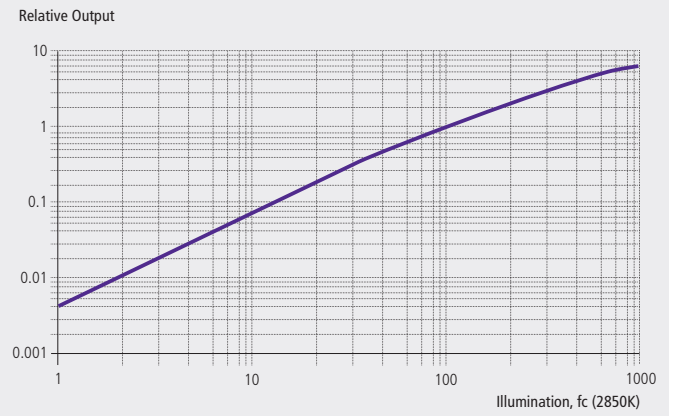

Graph 3

Angular Response Coax Packages

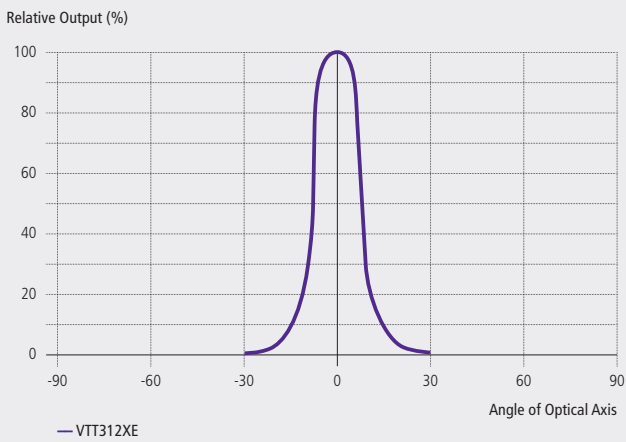

Graph 4

Angular Response Molded Epoxy Packages

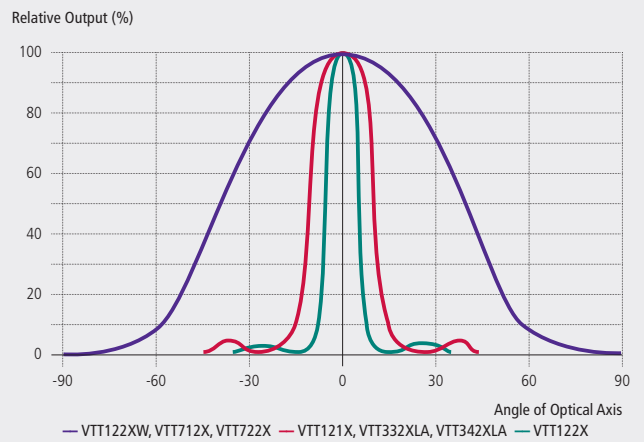

Graph 5

Angular Response Ceramic Packages

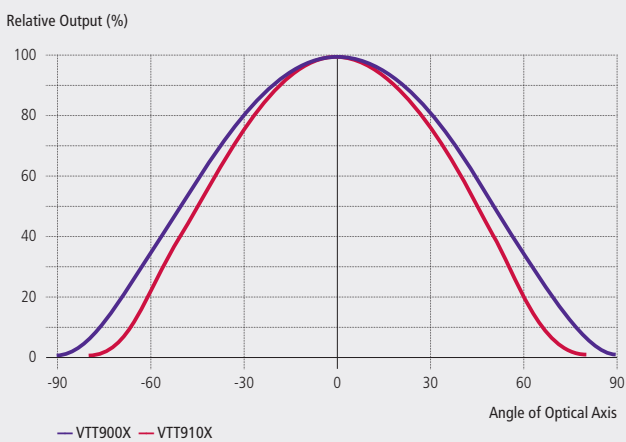

Graph 6

Angular Response 10-46 Packages

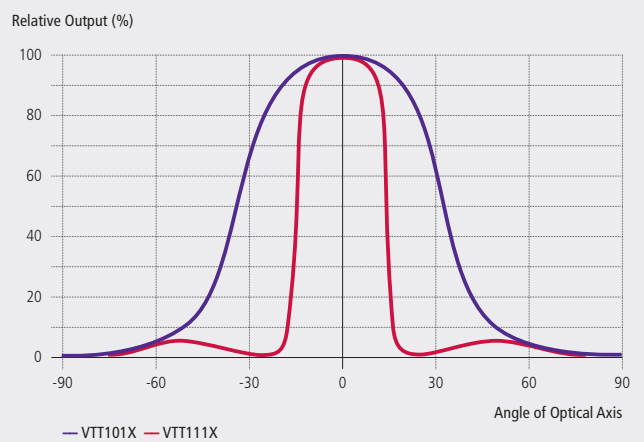

INFRARED SWITCHES

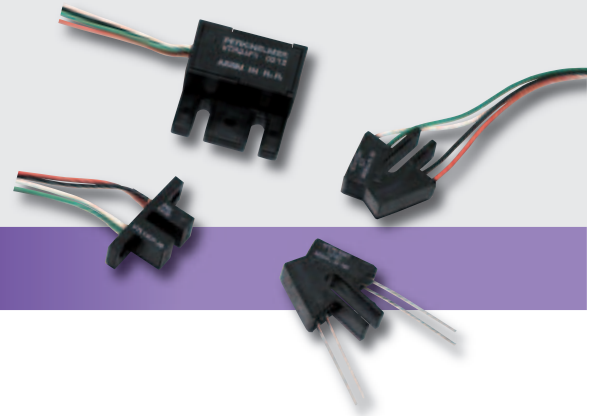

Infrared Switches – VTR – VTL Series

Applications

- Coin counters
- Paper-presence detection in copiers and printers
- Toner density control in copiers and printers
- Object sensing
- Distance detection
- Position sensing
- Rotational speed

Features and Benefits

- Fully integrated emitter and detector assembly
- Contains no mechanical parts to wear-out
- Provides non-contact object sensing
- Low power consumption
- Small size
- Low cost
- RoHS compliant

Product Description

PerkinElmer’s optoswitches are ideal for non-contact sensing applications. They consist of an emitter and a detector integrated in a plastic housing. The emitter is an IR LED while the detector is either a phototransistor or a photodarlington. These optoswitches are available either in transmissive or reflective configuration.

Product Table

VTR Series Reflective Optoswitch

Symbol	Light Current (min)				Dark Current (max)			Output Element Detector Device
	Test Conditions				Test Conditions			
	I_P	I_f	V_{CE}	d	I_d	I_f	V_{CE}	
Unit	mA	mA	V	mm	μ A	mA	V	
VTR16D1H	0.3	20	5	2.5	0.1	0	5	Phototransistor
VTR17D1H	0.3	20	5	2.5	0.1	0	5	Phototransistor
VTR24F1H	6.0	20	30	50.8	-	-	-	Photodarlington

VTL11D Series Transmissive Optoswitch

Symbol	Light Current (min)			Light Current (min)			Saturation Voltage (max)			Aperture Combination	
	Test Conditions			Test Conditions			Test Conditions			Emitter	Detector
	I_P	I_f	V_{CE}	I_d	I_f	V_{CE}	V_{SAT}	I_f	V_{CE}	Width	Width
Unit	mA	mA	V	nA	mA	V	V	mA	V	mm	mm
VTL11D1H	0.5	20	5	100	0	10	0.4	20	0.25	None	None
VTL11D1-20H	0.15	20	5	100	0	10	0.4	20	0.25	0.50	None
VTL11D3H	2	20	5	100	0	10	0.4	20	1.8	None	None
VTL11D3-20H	0.6	20	5	100	0	10	0.4	20	1.8	0.50	None
VTL11D5-20H	0.15	20	5	100	0	10	0.4	20	0.25	0.50	0.25
VTL11D6-20H	0.075	20	5	100	0	10	0.4	20	0.25	0.50	0.12
VTL11D7H	0.75	20	5	100	0	10	0.4	20	0.25	None	0.50
VTL11D7-20H	0.225	20	5	100	0	10	0.4	20	0.25	0.50	0.50

VTL23DxA Series Transmissive Optoswitch

Symbol	Light Current (min)			Light Current (min)			Saturation Voltage (max)			Aperture Combination	
	Test Conditions			Test Conditions			Test Conditions			Emitter	Detector
	I_P	I_f	V_{CE}	I_d	I_f	V_{CE}	V_{SAT}	I_f	V_{CE}	Width	Width
Unit	mA	mA	V	nA	mA	V	V	mA	V	mm	mm
VTL23D0A21H	0.2	20	10	100	0	10	0.4	20	0.1	0.50	0.25
VTL23D0A22H	0.2	20	10	100	0	10	0.4	20	0.1	0.50	0.50
VTL23D1A00H	0.5	20	10	100	0	10	0.4	20	0.4	1.0	1.0
VTL23D1A22H	0.5	20	10	100	0	10	0.4	20	0.4	0.50	0.50
VTL23D2A00H	2.5	20	10	100	0	10	0.6	20	1.8	1.0	1.0
VTL23D3A00H	1.0	10	10	100	0	10	0.4	10	0.8	1.0	1.0

HIGH POWER LASER DIODES FOR RANGE FINDING

PULSED LASER DIODES AND INFRARED LEDs (IREDS) ■

Pulsed Laser Diodes
PGA – PGEW Series

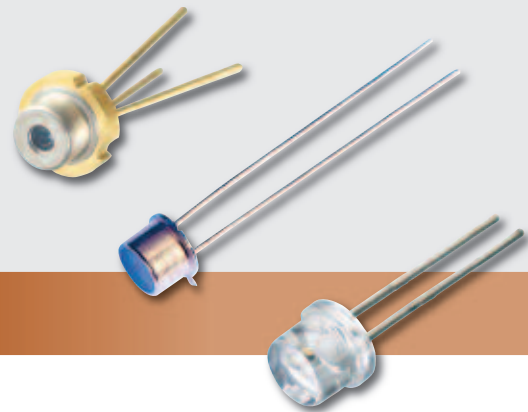

Pulsed Laser Diodes – PGA – PGEW Series

Applications

- Range finders
- Safety light curtains
- Adaptive cruise control
- Laser therapy

Features and Benefits

- Multi cavity lasers concentrate emitting source size
- Quantum well structure
- High peak pulsed power into aperture
- Excellent power stability with temperature

Product Description

Pulsed semiconductor lasers in the near IR are commonly used for long distance time-of-flight or phase-shift range finder systems. PerkinElmer offers a broad range of suited pulsed 905 nm lasers. Lasers designs include multi cavity monolithic structures with up to 4 active areas per chip resulting in up to 100 W of peak optical output power. Physical stacking of laser chips resulting in up to 300 W of peak optical output power.

Chip on board assemblies are available for hybrid integration. A selection of 6 metal, hermetically sealed package types are available for harsh environment applications. A molded epoxy resin TO-18 type package is available for high-volume applications.

Critical parameters are pulse-width and rise/fall times. The pulse width may be reduced allowing for increased current drive and resulting in higher peak optical power. Quantum well laser design offers rise and fall times of < 1 ns however the drive circuit lay out and package inductance play the greater role and should be designed accordingly. PerkinElmer offers a variety of package types with different inductive values to assist to this end.

Our core competencies include: MOVPE wafer growth; wafer processing of the grown GaAs wafers; assembly using either epoxy or solder die attach; epoxy encapsulation of lasers mounted on lead frame; hermetically sealer product qualification to MIL STD and custom requirements.

Product Table

PGA Pulsed Laser Family Selection Table, Typ. Wavelength 905 nm, 5 mm Spectral Width

Device (X = pkg) (H = RoHS Compliance)	Description		Emitting Area		Typical Peak Power at 10 A, 100 ns	Typical Peak Power at 30 A, 100 ns	Beam Spread Parallel to Junction (FWHM)	Beam Spread Perpendicular to Junction (FWHM)	Typical Temperature Coefficient	Preferred Packages	
	# of Chips	Total # of Emitting Stripes	Width µm	Height µm	75 µm (3 mils) Stripe Width	225 µm (9 mils) Stripe Width	Θ	Θ _⊥	nm / ° C	"S" Metall Can TO-18	"W" Plastic Encapsulated TO-18
PGAx1S03H	1	1	75	1	8 W		10	25	0.25	✓	✓
PGAx1S09H	1	1	225	1		30 W	10	25	0.25	✓	✓
DPGAx1S03H	1	2	75	5	15 W		10	25	0.25	✓	✓
DPGAx1S09H	1	2	225	5		50 W	10	25	0.25	✓	✓
TPGAx1S03H	1	3	75	10	23 W		10	25	0.25	✓	✓
TPGAx1S09H	1	3	225	10		75 W	10	25	0.25	✓	✓
QPGAx1S03H	1	4	75	15	33 W		10	25	0.25	✓	✓
QPGAx1S09H	1	4	225	15		100 W	10	25	0.25	✓	✓
TPGAx2S03H	2	6	75	175	45 W		10	25	0.25	✓	
TPGAx2S09H	2	6	225	175		150 W	10	25	0.25	✓	
QPGAx2S03H	2	8	75	225	65 W		10	25	0.25	✓	
QPGAx2S09H	2	8	225	225		200 W	10	25	0.25	✓	
QPGAx3S03H	3	12	75	450	95 W		10	25	0.25	✓	
QPGAx3S09H	3	12	225	450		300 W	10	25	0.25	✓	

Graph 1

Peak Radiant Intensity vs. Temperature

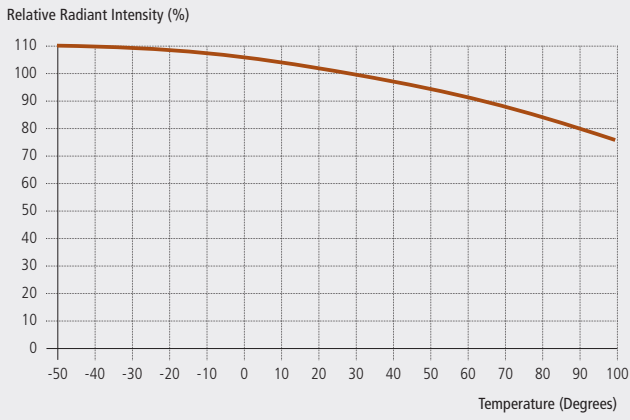

Graph 2

Radiant Intensity vs. F Number

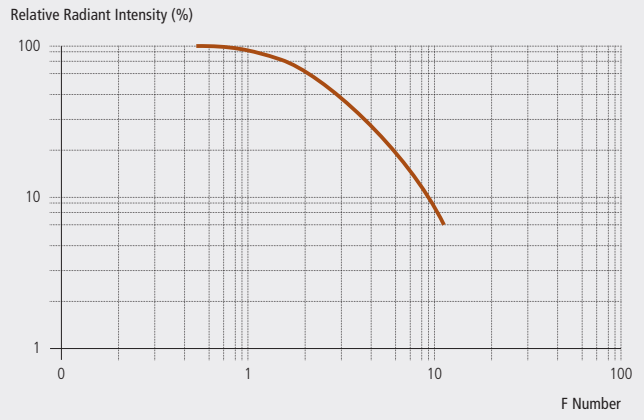

Graph 3

Spectral Plot Distribution

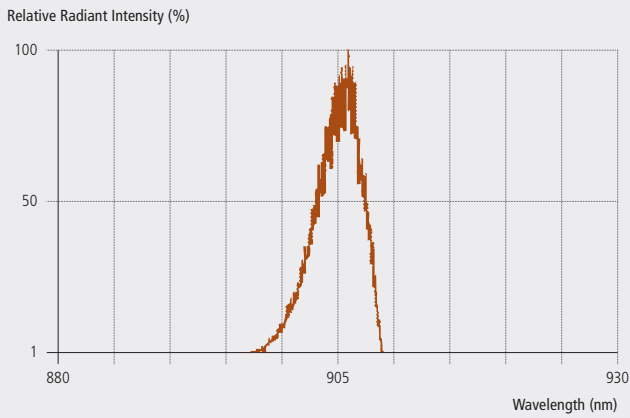

Graph 4

Radiant Intensity vs. Pulse Width for Safe Operation

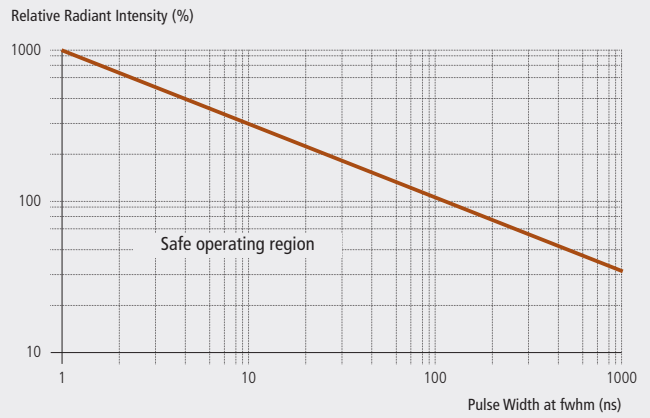

Graph 5

Safe Operation Region (Plastic Encaps.)

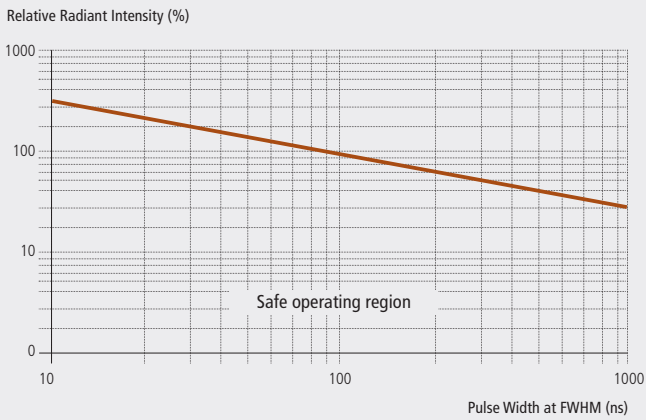

Graph 6

Center Wavelength vs. Temperature

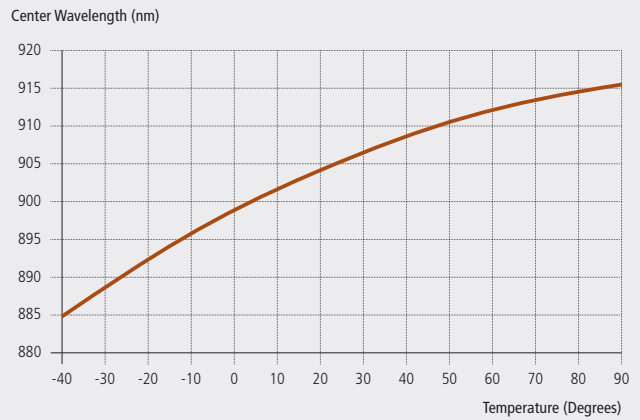

QP6EW currently being verified.

Figure 1

Package Drawing

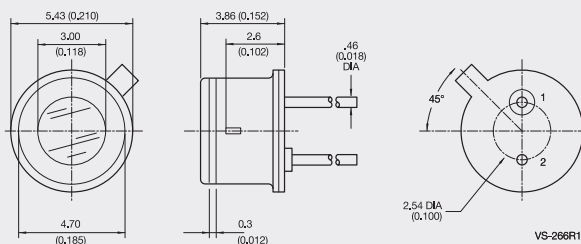

Package S (TO-18)

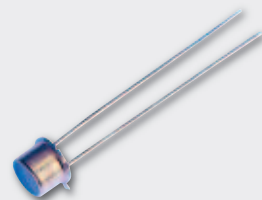

Pin out
 1. LD Anode (+),
 2. LD Cathode (-) Case,
 Inductance 5.2 nH

Figure 2

Package Drawing

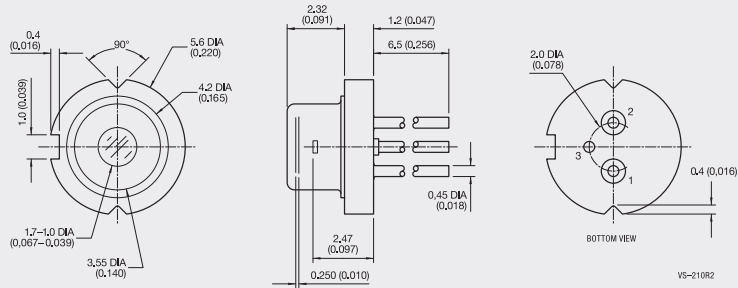

Package U (5 mm CD)

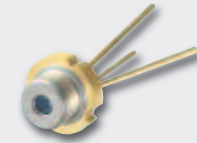

Pin out
 1. LD Anode (+),
 2. NC,
 3. LD Cathode (-) Case,
 Inductance 5.0 nH

Figure 3

Housing / Package Drawing • Laser Chip on Board

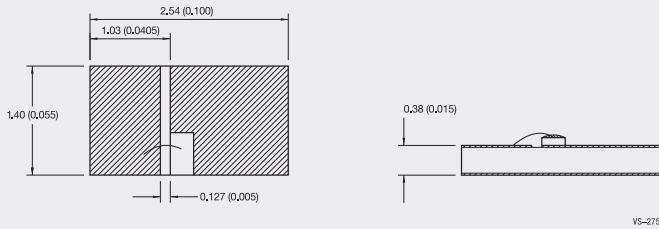

Package Y (Chip on Carrier)



Pin out
 1. LD Cathode (-) chip bottom,
 2. LD Anode (+) chip top,
 Inductance 1.6 nH

Figure 4

Package Drawing

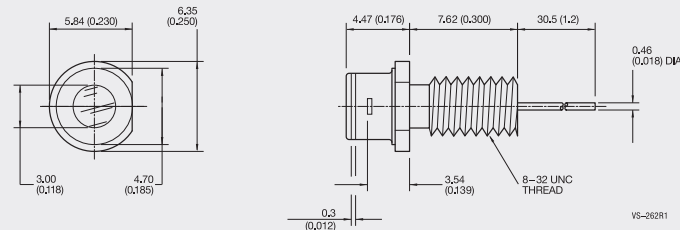

Package C (8-32 Coax)



Pin out
 1. LD Anode (+),
 2. LD Cathode (-) Case,
 Inductance 12 nH

Figure 5

Package Drawing

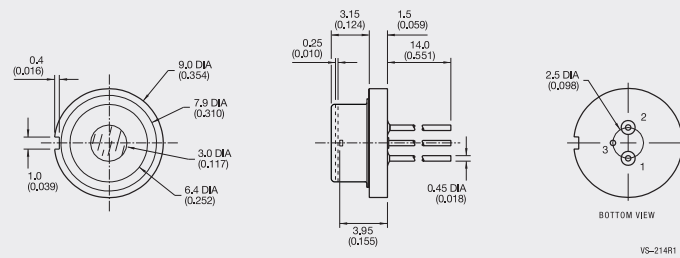

Package R (9 mm CD)



Pin out
 1. LD Anode (+),
 2. NC,
 3. LD Cathode (-) Case,
 Inductance 6.8 nH

Figure 6

Housing / Package Drawing • TO-18-“W” Plastic Package (1S Devices Only)

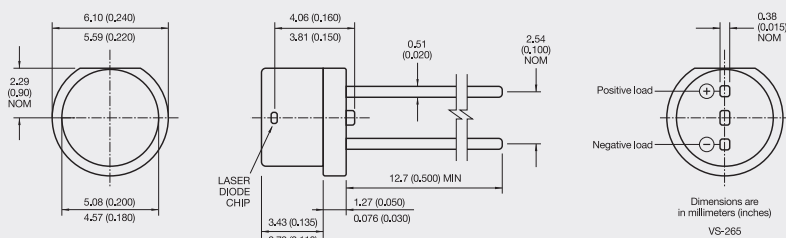

Package W (TO-18 Plastic)

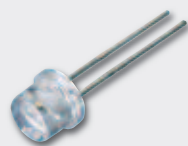

Pin out
 1. (Pkg Flat) LD Anode (+),
 2. LD Cathode (-),
 Inductance 5.0 nH

INFRARED EMITTING DIODES

FOR HIGH-VOLUME APPLICATIONS

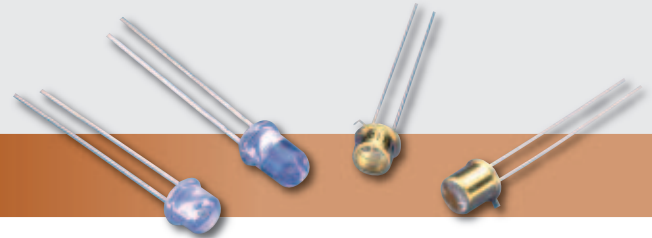

Infrared Emitting Diodes (IREDs) – VTE

Applications

- Consumer coin readers
- Lottery card readers
- Position sensors – joysticks
- Safety shields
- Encoders – measure speed and direction
- Printers – margin control
- Copiers – monitor paper position or paper stack height

Features and Benefits

- End and side radiating configurations
- Selection of emission angle spread using molded lenses
- Narrow band of emitted wavelengths
- Minimal heat generation
- Low power consumption

Product Description

IREDs are solid state light sources emitting in the near infrared part of the spectrum. The emission wavelength is closely matched to the response peak of silicon photodiodes and phototransistors. The product line provides a broad range of mounting lens and power output options. Both end and side radiating cases are available. Wide arrays of emission beam profiles are available. Devices may be operated in either CW or pulsed operating modes.

IREDs can be combined with PerkinElmer detectors or phototransistors in integrated assemblies for optoisolators, optical switches and retro sensors. Optical isolators are useful when electrical isolation is required, for example to transmit control logic signals to high power switching circuits (which can be noisy). In an optical switch an object is detected when it passes between the IRED and detector/phototransistor, for example a coin counter. In a retro sensor an object is detected when the IRED emitted beam is reflected onto the detector/photodetector. The retro sensor is used in applications where the object changes the reflectance, for example detecting the end of a ply wood sheet or other manufactured material.

Our core competencies include: LPE wafer growth; wafer processing of the grown GaAs wafers; assembly using either epoxy die attach; epoxy encapsulation of the IRED LEDs on lead frame; hermetically sealed package.

Product Table

Infrared Emitting Diodes (IREDs) – VTE

Part Number	Package	Irradiance	Distance	Diameter	Radiant Intensity	Total Peak Power	Forward Test Current	Forward Voltage Drop	Max Pulsed Forward Current	Wavelength	Beam Angle FWHM
Symbol		E_e typ.			I_e min.	P_o	CW • / Pulsed •	V_f max	I_f max		$\Theta \frac{1}{2}$
Unit		mW/cm ²	mm	mm	mW/sr	mW	mA	V	mA	nm	Degrees
VTE1013H	TO-46	2.7	36	6.4	27	30	1000 •	2.5	3000	940	±35
VTE1063H	TO-46	5.0	36	6.4	49	80	1000 •	3.5	3000	880	±35
VTE1113H	TO-46	15	36	6.4	156	30	1000 •	2.5	3000	940	±10
VTE1291-1H	T-1¾ (5 mm)	3.3	36	6.4	32	20	100 •	2.0	2500	880	±12
VTE1291-2H	T-1¾ (5 mm)	6.5	36	6.4	65	25	100 •	2.0	2500	880	±12
VTE1291W-1H	T-1¾ (5 mm)	1.6	36	6.4	16	20	100 •	2.0	2500	880	±25
VTE1291W-2H	T-1¾ (5 mm)	3.3	36	6.4	32	25	100 •	2.0	2500	880	±25
VTE1295H	T-1¾ (5 mm)	5.5	36	6.4	39	20	100 •	2.0	2500	880	±8
VTE3322LAH	T-1 (3 mm)	1.3	10.16	2.1	1.0	1.5	20 •	1.6	3000	940	±10
VTE3324LAH	T-1 (3 mm)	2.6	10.16	2.1	2.0	2.5	20 •	1.6	3000	940	±10
VTE7172H	Lateral 4.57x1.65mm	0.6	16.7	4.6	1.1	2.5	20 •	1.8	2500	880	±25
VTE7173H	Lateral 4.57x1.65mm	0.8	16.7	4.6	1.7	5.0	20 •	1.8	2500	880	±25
CR10IRD	SMD	-	-	-	-	6.3	50 •	2.05	800	770	-
CR50IRDA	SMD	-	-	-	-	20	50 •	1.8	800	870	±90
CR50IRH	SMD	-	-	-	-	10.6	50 •	1.85	800	870	±90
CR50IRK	SMD	-	-	-	-	11.4	50 •	1.7	800	950	±90

Graph 1

On Axis Rel. Irradiance T-1/Lateral Packages

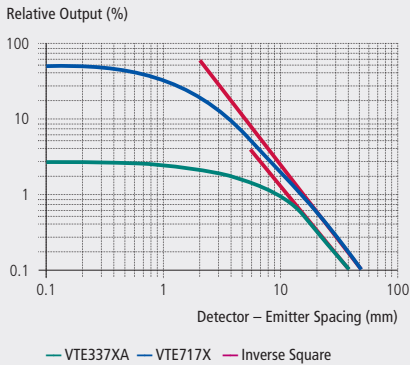

Graph 2

On Axis Relative Irradiance

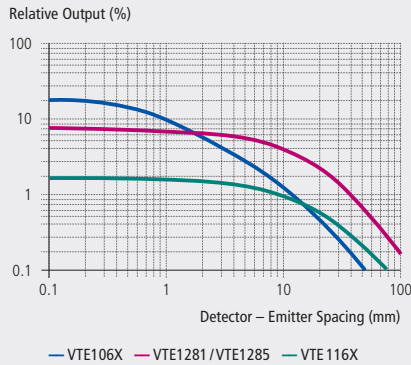

Graph 3

Angular Emission

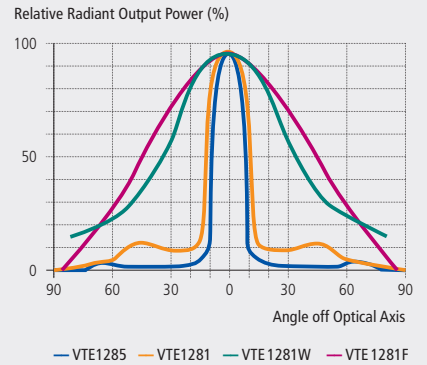
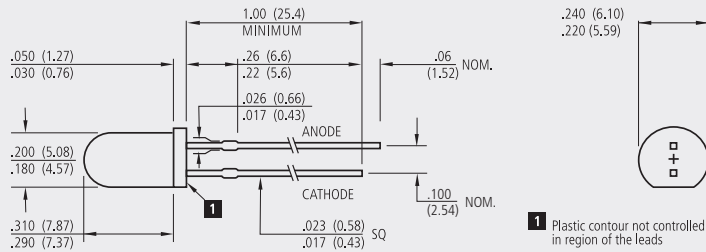

Figure 1

Housing / Package Drawing – VTE1291



VTE1291H



Narrow beam angle T-1¼ bullet package

Figure 2

Housing / Package Drawing – VTE1113H

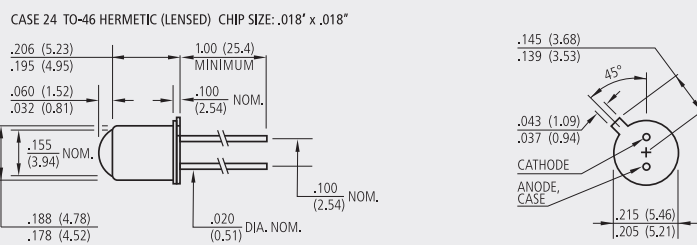

VTE1113H



TO-46 lensed cap

Figure 3

Housing / Package Drawing – VTE7172

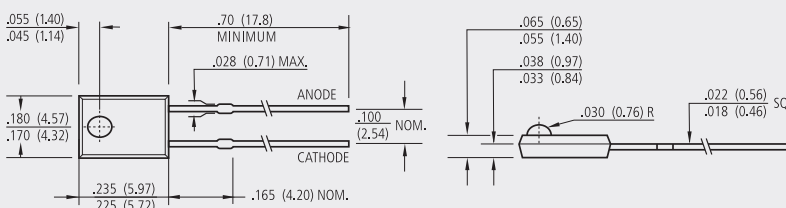

VTE7172H



Molded lateral package

PerkinElmer, Inc.
940 Winter Street
Waltham, MA 02451
USA
Telephone:
(+1) 800 762 4000 (toll-free)
(+1) 203-925-4602
www.perkinelmer.com

PerkinElmer, Inc.
22001 Dumberry Road
Vaudreuil-Dorion, Québec
Canada J7V 8P7
Telephone: (+1) 450 424 3300,
(+1) 866 574 6786 (toll-free)
Fax: (+1) 450 424 3345
opto@perkinelmer.com

PerkinElmer, Inc.
Wenzel-Jaksch-Str. 31
65199 Wiesbaden, Germany
Telephone: (+49) 611-492-247
Fax: (+49) 611-492-170
opto.Europe@perkinelmer.com

PerkinElmer, Inc.
47 Ayer Rajah Crescent #06-12
Singapore 139947
Telephone: (+65) 6775-2022
Fax: (+65) 6775-1008
opto.Asia@perkinelmer.com



For a complete listing of our global offices, visit www.perkinelmer.com/ContactUs

© 2009 PerkinElmer, Inc. All rights reserved. The PerkinElmer logo and design are registered trademarks of PerkinElmer, Inc. All other trademarks not owned by PerkinElmer, Inc. or its subsidiaries that are depicted herein are the property of their respective owners. PerkinElmer reserves the right to change this document at any time without notice and disclaims liability for editorial, pictorial or typographical errors.

008671A_01 Printed in Germany