

**BusWorks® XT Series
10/100MB Industrial Ethernet I/O Modules
USB Programmable, Modbus TCP/IP**

**Model XT1111-000, 16-Channel Sinking Digital I/O
16 Active-Low Inputs w/ 16 Low-Side Switch Outputs**

USER'S MANUAL



**ACROMAG INCORPORATED
30765 South Wixom Road**

Wixom, MI 48393-2417 U.S.A.

**Tel: (248) 295-0880
Fax: (248) 624-9234
email: sales@acromag.com**

Copyright 2014, Acromag, Inc., Printed in the USA.
Data and specifications are subject to change without notice.

8500949L

Table of Contents

GETTING STARTED

DESCRIPTION..... 4

- Key Features.....4
- Application4
- Mechanical Dimensions5
- DIN Rail Mounting & Removal.....5

ELECTRICAL CONNECTIONS 6

- Power Connections.....7
- Excitation Connections.....8
- USB Connection9
- Digital Input Connections.....10
- Digital Output Connections12
- EMI Filter Installation.....13
- Earth Ground Connections14

CONFIGURATION SOFTWARE..... 15

- Quick Overview15

TECHNICAL REFERENCE

CONFIGURATION STEP-BY-STEP 17

- Getting Connected.....17
- Device/Communication Setup.....18
- I/O Configuration & Test Page.....21
- i2o Mapping Page23
- Network Home Page.....25

BLOCK DIAGRAM 27

- How It Works.....27
- About Modbus TCP/IP28
- IP Addressing.....29
- Dynamic Host Configuration Protocol (DHCP).....30
- Domain Name System (DNS).....30

MODBUS REGISTERS 31

DESCRIPTION..... 31

- Register Functions32
- Data Types.....33
- Register Map33

TROUBLESHOOTING..... 36

 Diagnostics Table36

 Service & Repair Assistance38

ACCESSORIES 39

 Software Interface Package.....39

 USB Isolator.....39

 USB A-B Cable.....39

 USB A-mini B Cable Error! Bookmark not defined.

 DIN Rail Bus Connector Kit Error! Bookmark not defined.

 Low EMI Double-Shielded Patch Cable Error! Bookmark not defined.

SPECIFICATIONS 40

 Model Number41

 Digital Inputs41

 Digital Outputs42

 General43

 Power.....43

 USB Interface.....43

 Ethernet Interface.....44

 Enclosure & Physical45

 Environmental45

 Agency Approvals47

 Reliability Prediction.....47

 Configuration Controls.....47

REVISION HISTORY..... 48

All trademarks are the property of their respective owners.

IMPORTANT SAFETY CONSIDERATIONS

You must consider the possible negative effects of power, wiring, component, sensor, or software failure in the design of any type of control or monitoring system. This is very important where property loss or human life is involved. It is important that you perform satisfactory overall system design and it is agreed between you and Acromag, that this is your responsibility.

The information of this manual may change without notice. Acromag makes no warranty of any kind with regard to this material, including, but not limited to, the implied warranties of merchantability and fitness for a particular purpose. Further, Acromag assumes no responsibility for any errors that may appear in this manual and makes no commitment to update, or keep current, the information contained in this manual. No part of this manual may be copied, or reproduced in any form without the prior written consent of Acromag, Inc.

GETTING STARTED

DESCRIPTION

Symbols on equipment:



Means "Refer to User's Manual for additional information".

The XT1111-000 is a Modbus TCP/IP network control module for interface with up to 16 channels of tandem digital input/output for low-side (sinking) applications. This unit is setup and configured for network communication via a USB connection to any Windows-based PC (Windows XP and later versions only). The unit provides I/O channel isolation from network & power.

Key Features



- CE Approved, UL/cUL Class I, Division 2 Approved.
- Designed and Manufactured with High Quality/High Reliability with AS9100 (Aerospace Quality)/ISO9001.
- Modbus TCP/IP Protocol Support and w/ i2o Messaging Support.
- Conveniently setup and configured w/ Windows software via USB.
- High-Density 22.5mm wide package with pluggable, front-facing terminals.
- Dual Isolated 10/100Mbps Ethernet ports w/ Auto-Negotiation offers convenient "daisy chain" network connection which saves switch ports.
- Operation & Diagnostic LED indicators aide trouble-shooting.
- Bus Power and Bus Excitation Ready for Clean Wiring along the DIN Rail, or for Redundant Power and Redundant Excitation Connection.
- High 1500VAC Isolation between I/O Channels (as a group), the network (including port-to-port), and power.
- I/O, power, excitation, network, & USB ports are all transient protected.
- Tandem Input/Output channels allow loop-back monitoring of outputs.
- Discrete open-drain outputs switch up to 32V and 250mA each.
- Inputs use TTL thresholds and support up to 32V DC.
- Active-Low inputs include user-selectable logic inversion for inputs.
- I/O channels include 10K ohm pull-ups to Excitation.
- Outputs have built-in protection for transients & thermal overload.
- Failsafe Mode support w/Watchdog Timeout Control.
- Wide-range DC power input from 12-32V.
- Wide ambient temperature operation from -40°C to +60°C.
- Thoroughly Tested and Hardened For Harsh Environments.
- Withstands High Shock (25G) and Vibration (4G).
- Model XT-1111-000 is ATEX Certified for Explosive Atmospheres.
 Ⓜ II 3 G Ex nA IIC T4 Gc -40°C ≤ Ta ≤ +60°C DEMKO 15 ATEX 1561X

Application

These modules may be mounted side-by-side on 22.5mm centers along T-type DIN rail and units can even plug-together to share power and/or excitation connections along the DIN rail. This model interfaces with any mix of up to 16 digital inputs and/or outputs that are controlled/monitored via a 10/100Mbps Ethernet interface using the Modbus TCP/IP application protocol. Outputs are open-drain, switch up to 32V, and sink up to 250mA each. Inputs are TTL and accept up to 32V. The unit is conveniently setup and configured for network operation via a USB connection to a host personal computer running Acromag configuration software. The unit also supports i2o network messaging which can link discrete inputs of one unit to outputs of another.

Mechanical Dimensions

Units may be mounted to 35mm "T" type DIN rail (35mm, type EN50022), and side-by-side on 22.5mm (0.9-inch) centers.

WARNING: IEC Safety Standards may require that this device be mounted within an approved metal enclosure or sub-system, particularly for applications with exposure to voltages greater than or equal to 75VDC or 50VAC.

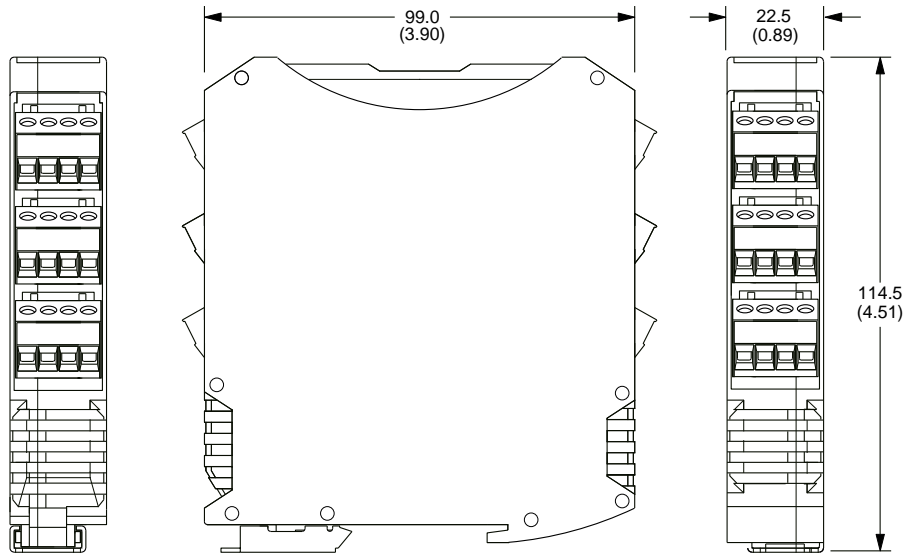

DIMENSIONS ARE IN MILLIMETERS (INCHES)

DIN Rail Mounting & Removal

Refer to the following figure for attaching and removing a unit from the DIN rail. A spring loaded DIN clip is located on the bottom side. The opposite rounded edge at the bottom of the top side allows you to tilt the unit upward to lift it from the rail while prying the spring clip back with a screwdriver. To attach the module to T-type DIN rail, angle the top of the unit towards the rail and place the top groove of the module over the upper lip of the DIN rail. Firmly push the unit downward towards the rail until it snaps into place. To remove it from the DIN rail, first separate the input terminal blocks from the bottom side of the module to create a clearance to the DIN mounting area. You can use a screwdriver to pry the pluggable terminals out of their sockets. Next, while holding the module in place from above, insert a screwdriver along the bottom side path of the module to the DIN rail clip and use it as a lever to force the DIN rail spring clip down while pulling the bottom of the module outward until it disengages from the rail. Tilt it upward to lift it from the rail.

SERIES XT MODULE DIN RAIL MOUNTING AND REMOVAL

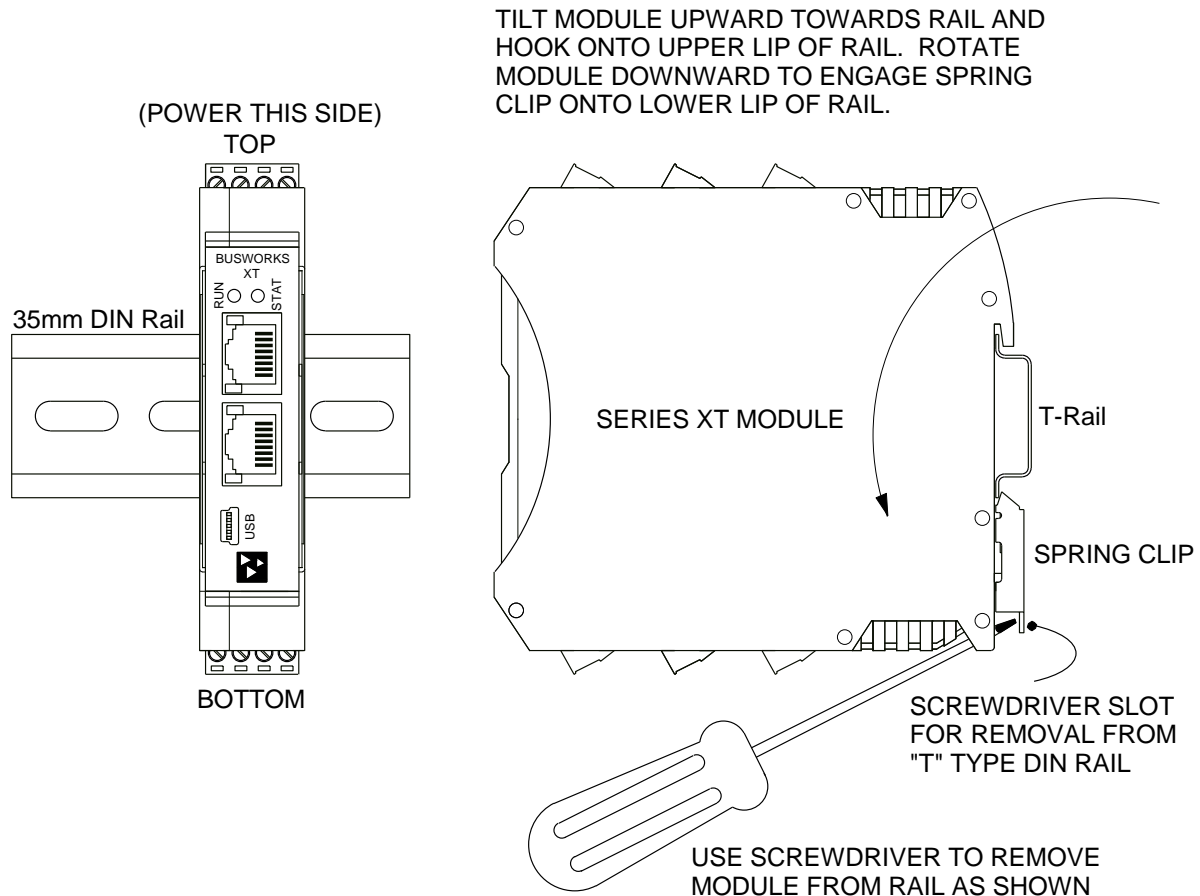

ELECTRICAL CONNECTIONS



WARNING – EXPLOSION HAZARD – Do not disconnect equipment unless power has been removed or the area is known to be non-hazardous.

WARNING – EXPLOSION HAZARD – Substitution of any components may impair suitability for Class I, Division 2.

WARNING – EXPLOSION HAZARD – The area must be known to be non-hazardous before servicing/replacing the unit and before installing.

Wire terminals can accommodate 14–26 AWG (2.08–0.13mm²) solid or stranded wire with a minimum temperature rating of 85°C. I/O wiring may be shielded or unshielded type. Terminals are pluggable and can be removed from their sockets by prying outward from the top with a flat-head screwdriver blade. Strip back wire insulation 0.25-inch on each lead and insert the wire ends into the cage clamp connector of the terminal block. Use a screwdriver to tighten the screw by turning it in a clockwise direction to secure the wire (use 0.5-0.6nM torque). Since common mode voltages can exist on I/O wiring, adequate wire insulation should be used and proper wiring practices followed. As a rule, I/O wires are normally separated from power and network wiring for safety, as well as for low noise pickup.

Power Connections

Connect a DC power supply from 12-32V as shown in the drawing below. Observe proper polarity (input power is reverse-polarity protected). Optionally, the unit may be powered (or redundantly powered) via its DIN rail connector (optional terminal required, see below). For supply connections, use 14 AWG wire rated for at least 80°C. Do not exceed 36V DC peak. It is best to apply earth ground at DC-, closest to the module, but never at both ends of the cable.

MODEL XT1xxx-000 POWER WIRING UNIT IS DC-POWERED ONLY AT 12 TO 32VDC.

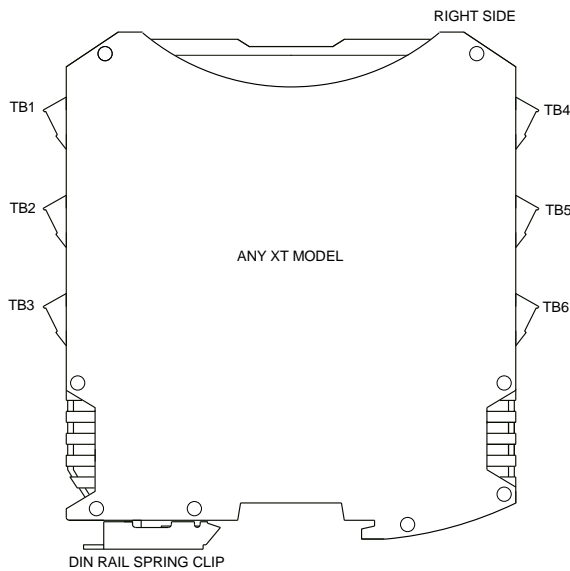

ANY XT1xxx-000 RIGHT EDGE VIEW

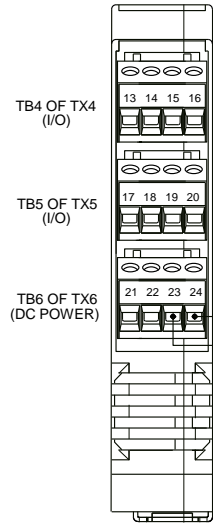

POWERING INDIVIDUAL MODULES VIA SCREW TERMINALS ON UNIT

NOTE: IT IS RECOMMENDED THAT SUPPLIES CAPABLE OF DELIVERING MORE THAN 2.5A TO THE UNIT BE FUSED WITH A HIGH SURGE TOLERANT FUSE.

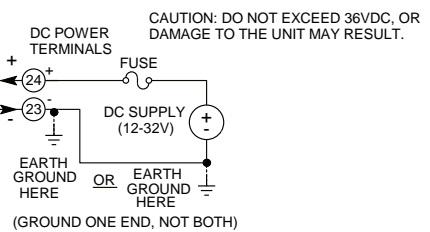

IT IS BEST TO APPLY EARTH GROUND CLOSEST TO THE MODULE, BUT NEVER AT BOTH ENDS OF THE CONNECTION.

POWER INPUT IS ISOLATED FROM I/O AND NETWORK CIRCUITS.

OPTIONAL/REDUNDANT RAIL (BUS) POWER

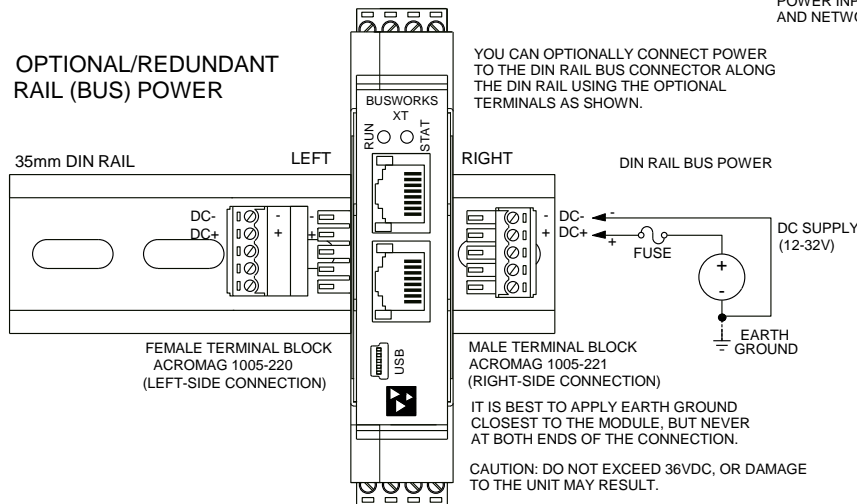

YOU CAN OPTIONALLY CONNECT POWER TO THE DIN RAIL BUS CONNECTOR ALONG THE DIN RAIL USING THE OPTIONAL TERMINALS AS SHOWN.

IT IS BEST TO APPLY EARTH GROUND CLOSEST TO THE MODULE, BUT NEVER AT BOTH ENDS OF THE CONNECTION.

CAUTION: DO NOT EXCEED 36VDC, OR DAMAGE TO THE UNIT MAY RESULT.

NOTE: IT IS RECOMMENDED THAT SUPPLIES CAPABLE OF DELIVERING MORE THAN 2.5A TO THE BUS BE FUSED WITH A HIGH SURGE TOLERANT FUSE.

Power Connections...

Note that you can use the bus power connector of the module to interconnect modules by plugging them together and connecting them as a group to a suitable power supply using an optional left or right terminal block, 1005-220 or 1005-221, as shown below. You can even make I/O Excitation connections along the bus with these connectors (see below, note that Excitation is isolated from DC power).



Important – End Stops: If this module uses the optionally powered (or redundantly powered) via the DIN rail bus for hazardous location installations (Class I, Division 2 or ATEX Zone 2) it must use two end stops (Acromag 1027-222) to secure the terminal block and module (not shown).

XT MODEL OPTIONAL BUS POWER WIRING

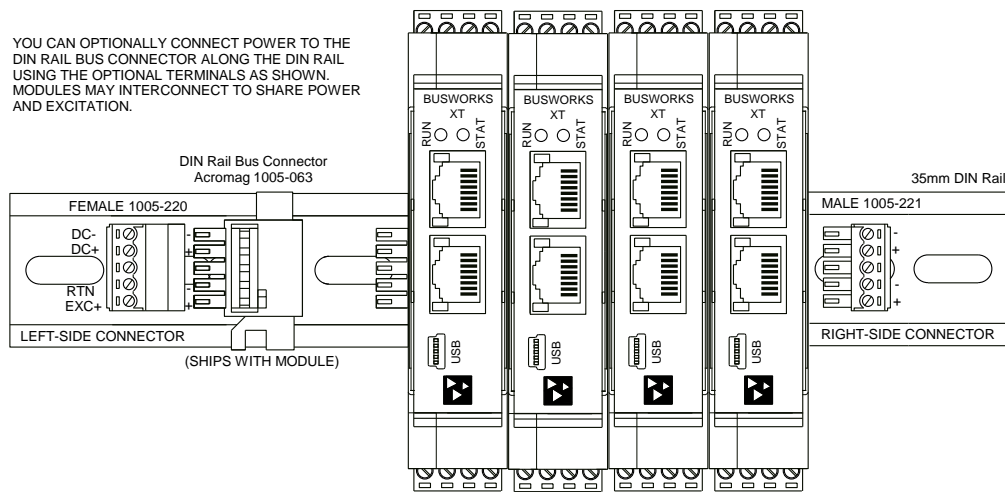

Excitation Connections

You must connect 4-32V of excitation to operate the outputs of this model.

Outputs are the drains of n-channel mosfet switches pulled-up to the excitation rail via 10KΩ resistors and with their sources connected to RTN (all mosfet source leads are held in common at Return). Connect DC excitation from 4-32V as shown in the drawing of the next page and observe proper polarity (excitation is reverse-polarity protected). Optionally, excitation may be delivered (or redundantly delivered) via a DIN rail connector (optional terminal required, see above). For excitation connections, use 14 AWG wire rated for at least 80°C. Do not exceed 36V DC peak.

Excitation Connections...

MODEL XT111x-000 EXCITATION WIRING
I/O EXCITATION IS DC ONLY AT 4 TO 32V.

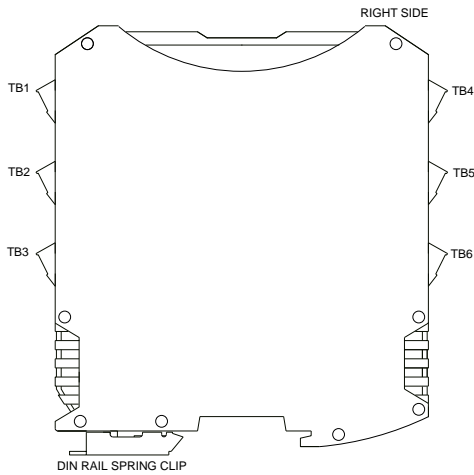

XT111x-000 WIRING EXCITATION TO MODULES
VIA SCREW TERMINALS ON UNIT

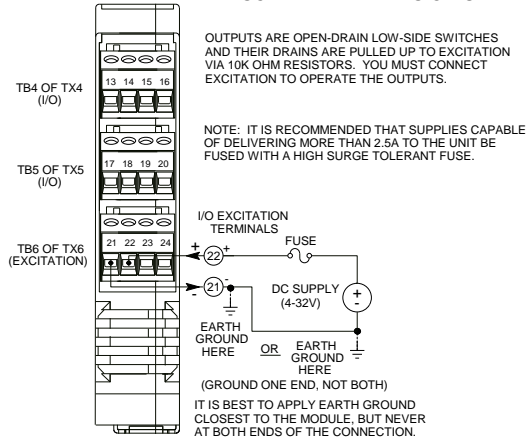

OPTIONAL OR REDUNDANT RAIL (BUS) EXCITATION

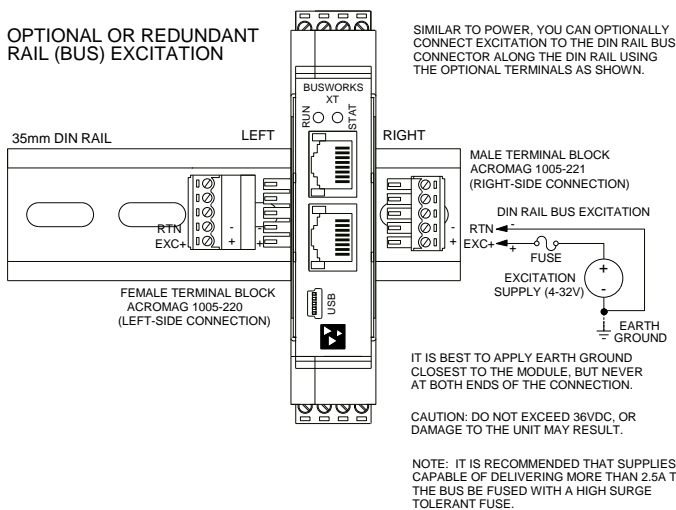

USB Connection



WARNING: The intent of mating USB with this unit is so that it can be conveniently setup and configured in a safe area, then installed in the field which may be in a hazardous area. Do not attempt to connect a PC or laptop to this unit while installed in a hazardous area, as USB energy levels could ignite explosive gases or particles in the air.

- **USB Signal Isolation is Recommended** - You may use Acromag model USB-ISOLATOR to isolate your USB port, or you can optionally use another USB signal isolator that supports USB Full Speed operation (12Mbps).
- **Reconfiguration Does Not Require a Network Connection, as it uses a USB connection.**
- **Connect Unit to Power Before USB.**

XT SERIES USB MODULE CONNECTIONS

USED FOR CONFIGURATION ONLY IN A SAFE OR ORDINARY LOCATION

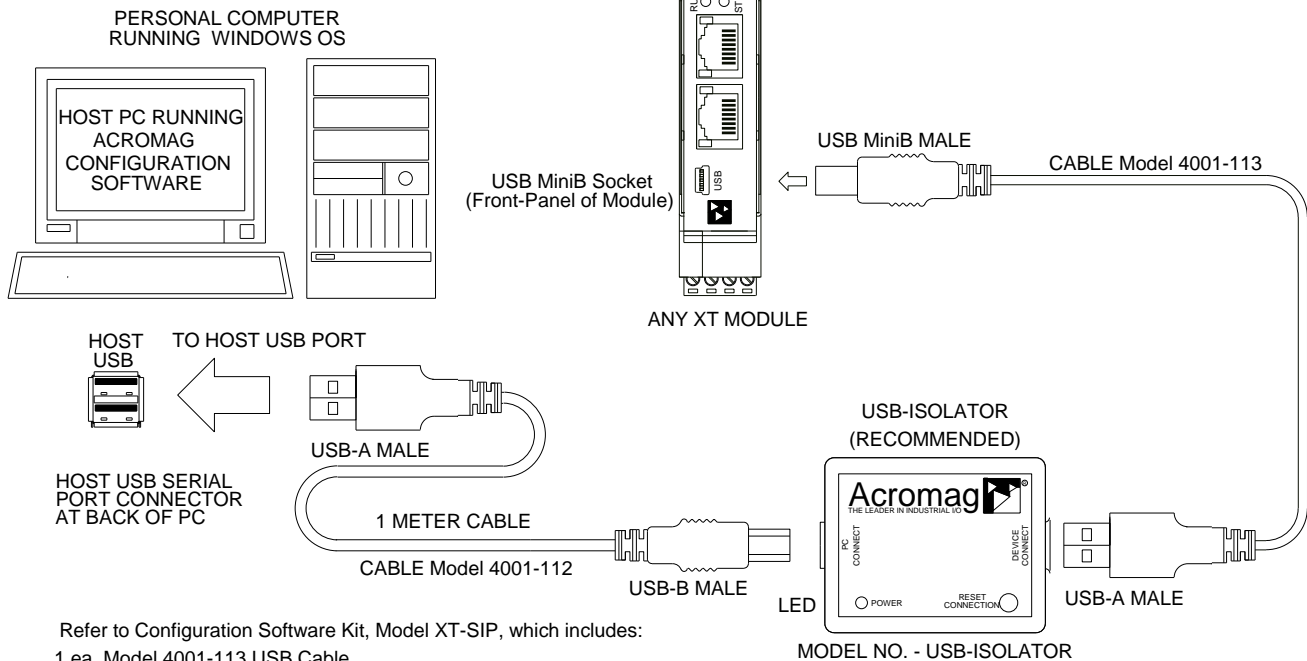

Refer to Configuration Software Kit, Model XT-SIP, which includes:

- 1 ea, Model 4001-113 USB Cable
- 1 ea, Model 4001-112 USB Cable
- 1 ea, Model USB-ISOLATOR
- 1 ea, Model XT-CONFIG CDROM Software
- 1 ea, Model 5035-360 Ethernet Cable

Digital Input Connections

The sixteen inputs of this model are already wired to accomplish loopback monitoring of the open-drain outputs, but may alternately be used to monitor input levels from the field when their tandem outputs are switched OFF. Inputs accept voltage signals up to 32V, are active-low, and use TTL thresholds for logic transfer. They additionally are pulled up to Excitation via 10K pull-up resistors installed on-board. Observe proper polarity when making I/O and Excitation connections. Refer to the following figures to wire the active-low inputs of this model.

IMPORTANT: Do not allow unused I/O channels to float. This will occur if you operate I/O without also connecting I/O Excitation, as the I/O channels each have 10KΩ pull-ups to the excitation rail. Likewise, failure to connect excitation would allow channels to pull each other via their pull-up resistors.

Digital Input Connections...

IMPORTANT: When driving inputs from the field, be sure to turn off the channel's corresponding tandem output to prevent contention between the module's output and the field signal.

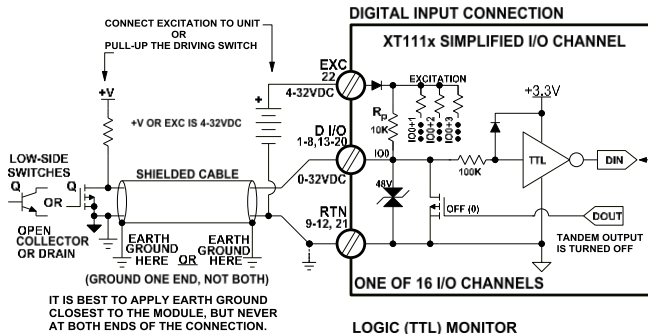

IT IS BEST TO APPLY EARTH GROUND CLOSEST TO THE MODULE, BUT NEVER AT BOTH ENDS OF THE CONNECTION.

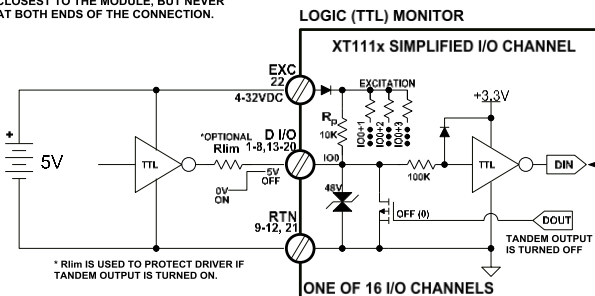

* Rlim IS USED TO PROTECT DRIVER IF TANDEM OUTPUT IS TURNED ON.

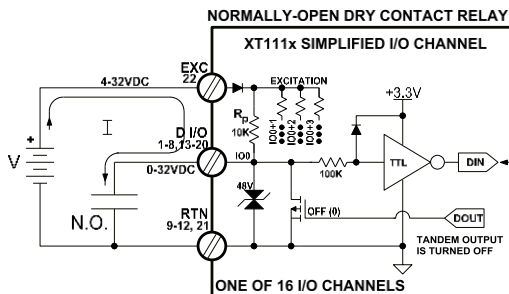

XT111x-000 INPUT OPERATION

INPUTS ARE ACTIVE LOW w/ TTL THRESHOLDS
INPUTS INCLUDE 10K PULL-UP RESISTORS
INPUTS ARE 0-32VDC

XT111x-000

BOTTOM VIEW

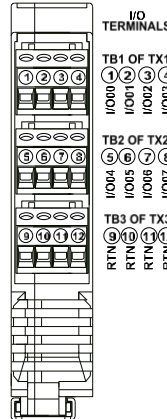

TOP VIEW

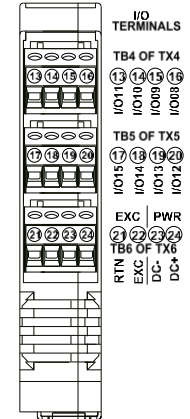

NOTE: UNUSED CHANNELS & FLOATING EXCITATION

WITHOUT EXCITATION CONNECTED, UNUSED INPUT CHANNELS CAN FLOAT AND THEIR REGISTER READINGS MAY BE UNPREDICTABLE. IT IS SUGGESTED THAT YOU EITHER CONNECT EXCITATION, SHORT UNUSED INPUTS TO RTN, OR PULL-UP UNUSED INPUTS.

Digital Output Connections

Sixteen smart open-drain (low-side) N-channel mosfets that switch the load to ground (return) and include 10K pull-up resistors to EXC.

You must connect Excitation to operate the outputs. Outputs will switch loads up to 32V and 250mA each. Note that since each output channel drain lead is pulled up to excitation via a 10K pull-up resistor, one channel can pull on another channel if the excitation rail is left floating. Observe proper polarity when making I/O connections. Refer to the following figures to wire the outputs of this model.

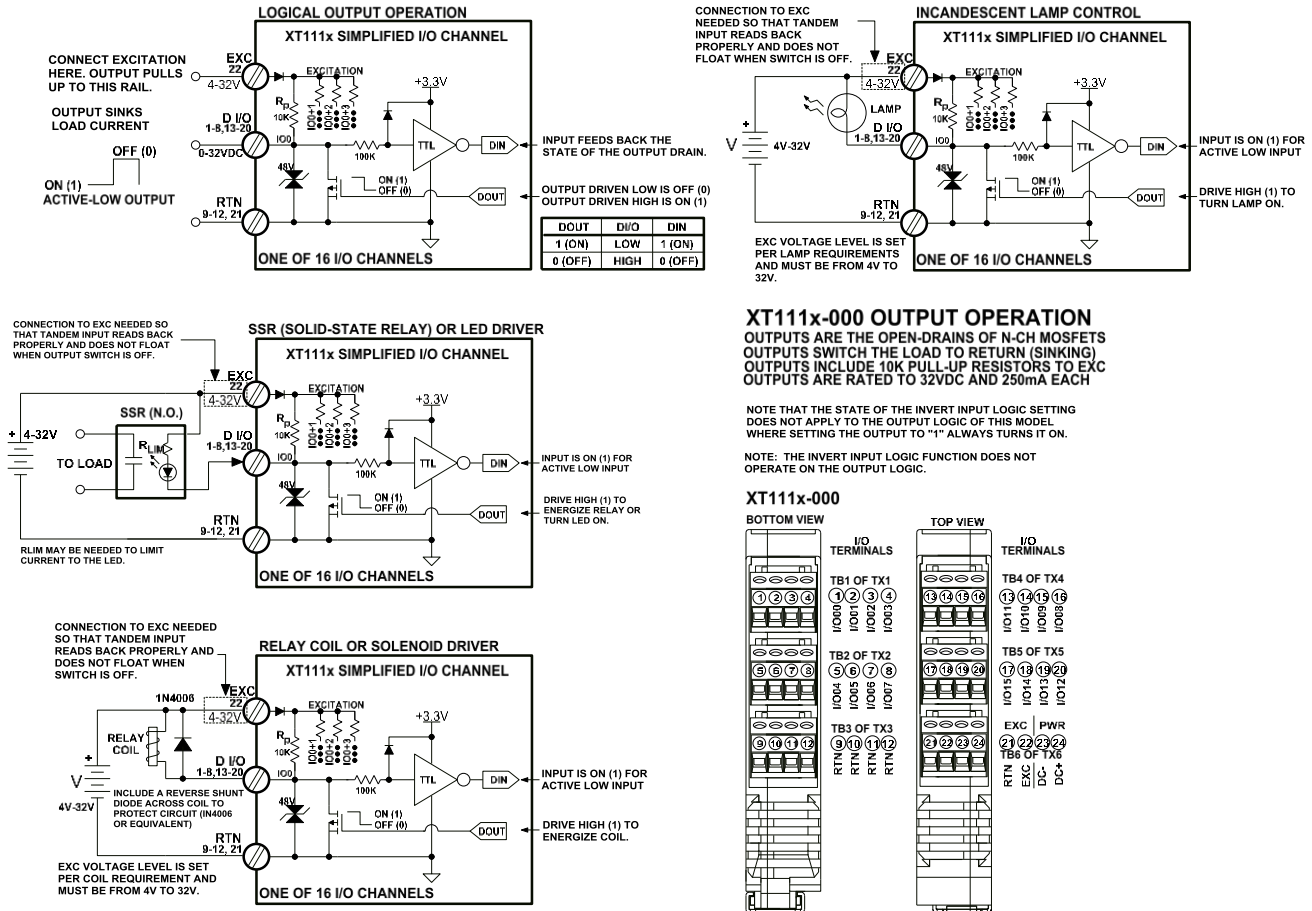

NOTE: You must connect EXC to a voltage source from 4-32V to operate outputs, do not allow Excitation to float.

IMPORTANT – Add Protection with Inductive Loads: Outputs do include integrated reverse-bias shunt diodes to help protect the output switch from damage due to high reverse-bias voltages generated when switching inductive loads. But you should add external protection near the inductive load to prevent these transients from being sent along the connection wires. Place a diode (1N4006 or equivalent) across an inductive load with the cathode to (+) and the anode to (-).

For greater drive capability or for switching AC loads, it is common to use an appropriately rated interposing relay. Add protection local to the relay as noted above when driving inductive relay coils.

Per UL, when the outputs are used to drive interposing relays for switching AC or DC devices of higher voltage/current, the coil ratings for the interposing relay shall not exceed 24VDC, 100mA.

EMI Filter Installation

For low CE-rated emissions, the use of split type snap-on ferrite cores on all cables or harnesses to/from the device as shown in the drawing below is helpful. Use Laird 28A2029-0A2 or similar for I/O, Ethernet, and Power (order Acromag 4001-135) and Laird 28A0350-0B2 or similar for USB cables (Acromag 4001-136). Locate this ferrite by clamping it outside of all input/output cables or wiring harnesses to/from the module (USB, Ethernet, I/O group, DC power), as close to the module as possible. While the use of ferrites is helpful to obtain low CE-rated emissions, it may not be required for your application. Note also cables may share a ferrite, but it is not good practice to combine isolated circuits inside the same ferrite. Separate isolated circuits for increased safety and greater noise immunity.

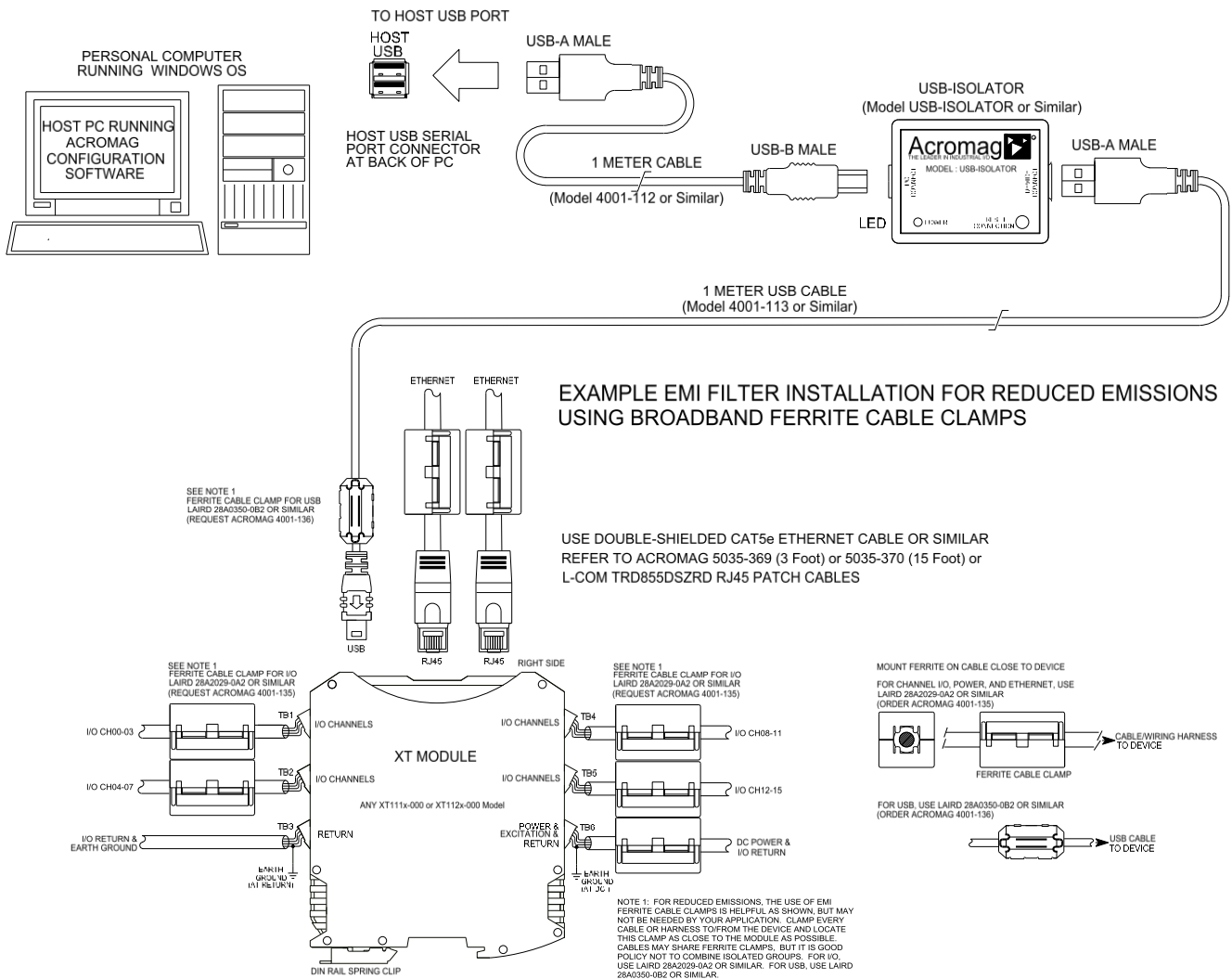

Earth Ground Connections

The unit housing is plastic and does not require an earth ground connection to itself. If the module is mounted in a metal housing, an earth ground wire connection to the metal housing's ground terminal (green screw) is usually required using suitable wire per applicable codes. Circuits wired to power, I/O, and the network should be earth grounded as reflected in the connection diagrams. The ground connections noted are recommended for best results and help protect the unit by giving it a low impedance path to ground for shunting destructive transient energy. See the Electrical Connections Drawings for I/O, power, and network ground connections.

Note: A USB isolator is recommended when connected to a grounded Personal Computer for configuration purposes. This will avoid a potential ground loop that can occur if the I/O signal is already earth grounded, as a PC commonly earth grounds its USB port and contacts both the USB signal and shield ground which is held in common to the input circuit return of this module.

CONFIGURATION SOFTWARE

While this is a Modbus TCP/IP I/O module, it can only be configured and calibrated via its Configuration Software over a USB connection to a Windows-based PC or laptop. USB saves you the trouble of having to already know its set IP address, or having to change the address setting of your network interface card to match its domain, in order to communicate with it. USB software is contained in a zip file that can be downloaded free of charge from our web site at www.acromag.com. Look for the software zip file 9500462 in the Documents and Downloads page for your XT product. Initially, you will have to answer a few questions to open a user account and download this file to your computer. This zip file will extract to an executable file, which installs *modelconfig.exe* executable files in an Acromag subdirectory off the Program Files directory of your PC. Note that you must have administrator rights to download and install this software onto your PC or laptop. Once you have installed the software, be sure to navigate to the *Program Files\Acromag* subdirectory and select the correct *modelconfig.exe* software for your module. This same software is also included on a CDROM bundled with the Configuration Kit XT-SIP (see Accessories), but downloaded from the web will ensure that the software is the most up-to-date. The software is compatible with XP or later versions of the Windows operating system. The *modelconfig.exe* software for this unit supports five other model variations—three models with 16 sinking outputs and active-low inputs, and three models with 16 sourcing outputs and active-high inputs.

Quick Overview

After booting the Configuration software for this model, the Device/ Communication Setup page will appear. Once you Select a device & click “Open” to connect to an XT1111-000 or XT1121-00, your screen will look similar to the following:

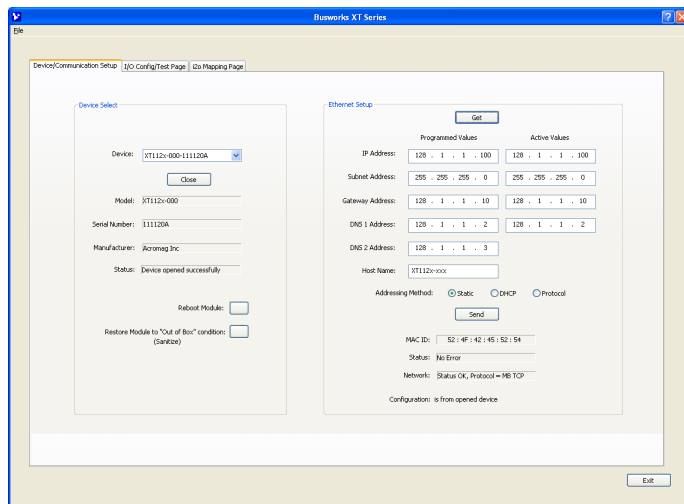

For a more detailed configuration procedure, see the **Configuration Step-by-Step** section of the **Technical Reference** on page 17 of this manual.

IMPORTANT: Delay clicking [Open] immediately after power-up until it has established its Ethernet connection (wait ~30 seconds after power-up to give it time to initialize), otherwise data transfer or timeout errors may result. If this occurs, turn power off to the unit, close the software, then turn power back on and reboot the software after unit has powered up.

The initial configuration software screen for this model is shown at left. This screen is used to select and identify USB connected units, and to configure the Ethernet parameters necessary to communicate over the network. There are two other screens that can be selected by clicking their tabs, I/O Config/Test, and i2o Mapping. A short description of the controls of this page follows:

Device Select (First Connect to the Unit Here)

- Select from connected modules and Open communication with them.
- Display the Model, Serial Number, and Manufacturer of the connected module and report the status of the connection.
- Reboot a module to force a system reset to its power-up state.
- Restore a module to its initial programmed “out-of-box” state.

Ethernet Setup (Setup your Network Parameters)

- Retrieve the connected modules current network configuration.
- Set the Network IP address required for Ethernet communication on your network.
- Set the subnet mask, gateway, and/or domain name server addresses for your network.
- Write your parameters to the connected unit and read back the network communication status.

Quick Overview...

HELP – You can press F1 for Help on a selected or highlighted field or control. You can also click the [?] button in the upper-right hand corner of the screen and then click to point to a field or control to get a Help message pertaining to the item you pointed to.

If you click on the I/O Config/Test Page tab, the following screen will appear:

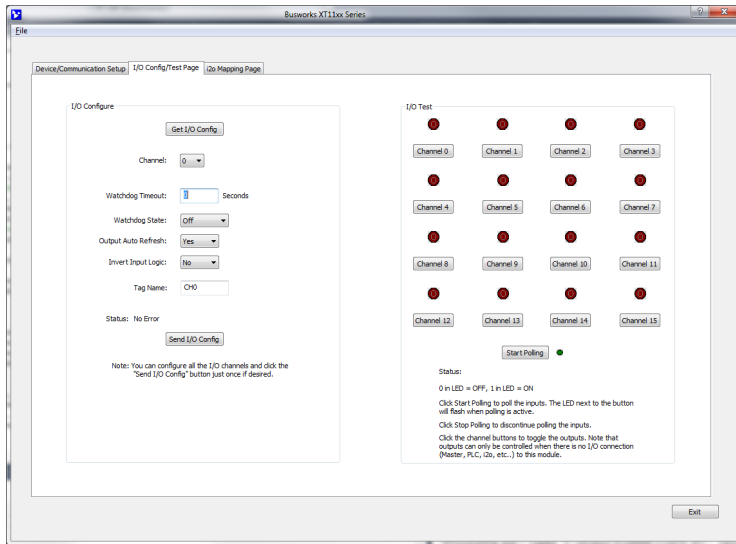

If you click the i2o Mapping tab, the following screen will appear:

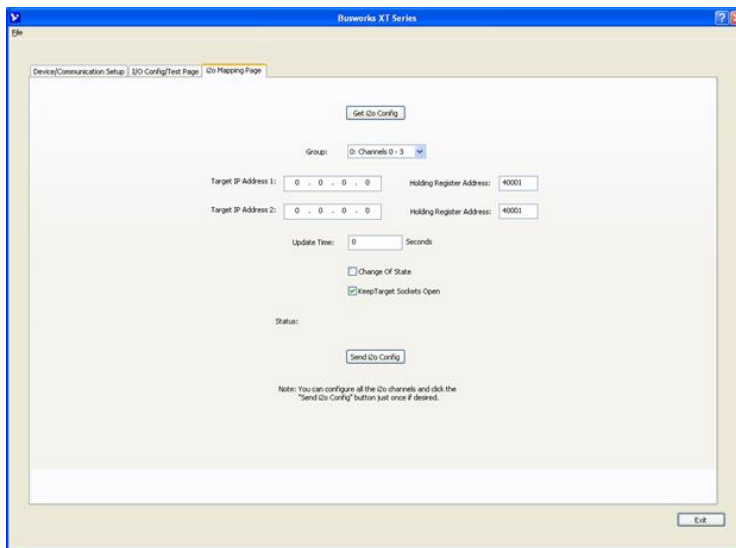

For a more detailed configuration procedure, see the Configuration Step-by-Step section of the Technical Reference on page 17 of this manual.

I/O Configure

- Retrieve the connected modules current channel configuration.
- Configure a watchdog timer for the output channel, and optionally a timeout state. Setup auto-refresh for the output to combat digital upset or force a restart following thermal shutdown. You can even choose to invert the logic for the tandem input channel (inverts the fieldbus input logic and its optional i2o data (see below).
- Apply a tag name to the I/O channel for reference purposes.
- Send your channel configuration to the connected unit.

I/O Test

After making I/O configuration changes, you can use the I/O Test controls to verify operation of your I/O.

- Start/Stop polling the input channels.
- Display the current state of the inputs.
- Turn Outputs On/Off.

i2o Mapping

This model includes a special remote messaging function called i2o, for input-to-output communication. This allows it to send its digital input information over the network, to digital outputs on another unit, or a compatible unit, without having to hard-wire a connection. The i2o Mapping Page shown at left is used to setup this feature by specifying the IP address of the target output module to send input channel data to, either upon change-of-state, or cyclically at the update time specified.

- Set the IP address of one or two target devices to send input data to their output channels.
- Specify to send data upon change of state, or cyclically per an update rate that you specify.
- Retrieve the current i2o configuration from the connected module, or send a new configuration to the connected module.

TECHNICAL REFERENCE

CONFIGURATION STEP-BY-STEP

Getting Connected

This section will walk you through the Connection-Configuration process step-by-step. But before you attempt to reconfigure this module, please make the following electrical connections.

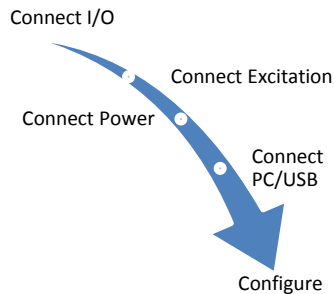

1. **Connect I/O:** Refer to Input and Output Connections at the front of this manual and connect your I/O as required for your application.
2. **Connect Excitation:** You cannot operate the I/O channels of this model without connecting excitation across the EXC & RTN terminals on the unit. I/O channels are pulled up to the EXC rail with 10K Ω resistors and must not be allowed to float. This model requires an excitation supply from 4-32V (52mA minimum). The actual required current capability will depend on your loads and voltage level. You can choose to connect to Excitation via terminals on the unit, or via optional terminals that connect to the module's bus connector along the DIN rail (See Power and Excitation Connections). Outputs will not operate properly if you do not connect Excitation.
3. **Connect Power:** You need to connect power from 12-32V to power this module. You can choose to connect to Power via terminals on the unit, or via optional terminals that connect to the module's bus connector along the DIN rail (See Power and Excitation Connections). Current required will vary with voltage level (refer to Specifications). Your supply must be capable of providing at least twice the maximum rated current for your voltage level.
4. **Connect to PC via USB:** Refer to USB Connections of page 9 and connect the module to your PC or laptop using the USB isolator and cables provided in Configuration Kit XT-SIP.

Now that you have made your connections and applied power, you can execute the XT11xxConfig.exe software to begin configuration of your unit (software is compatible with XP or later versions of the Windows operating system). Note that the same software is used for both DIO models, XT1111-000 with 16 sinking outputs, and XT1121-000 with 16 sourcing outputs.

IMPORTANT: Allow the unit to fully power-up and establish its Ethernet connection before attempting to open USB communications with the unit using the XT11xxconfig.exe software (wait ~30 seconds after powering-it up to give it time to initialize).

Note that you do not connect your module to an Ethernet network in order to configure it. It is configured for network operation by initially connecting to USB and a host PC running model-specific configuration software running under a Windows operating system. This has the advantage of not having to know the modules IP address setting, or having to change the address setting of your network card to match its subnet address, in order to talk to it.

Device/Communication Setup

After executing the Acromag Configuration software for this model, the screen shown below will appear, if you have not already connected to your module via USB (note Device Select fields are blank under these conditions).

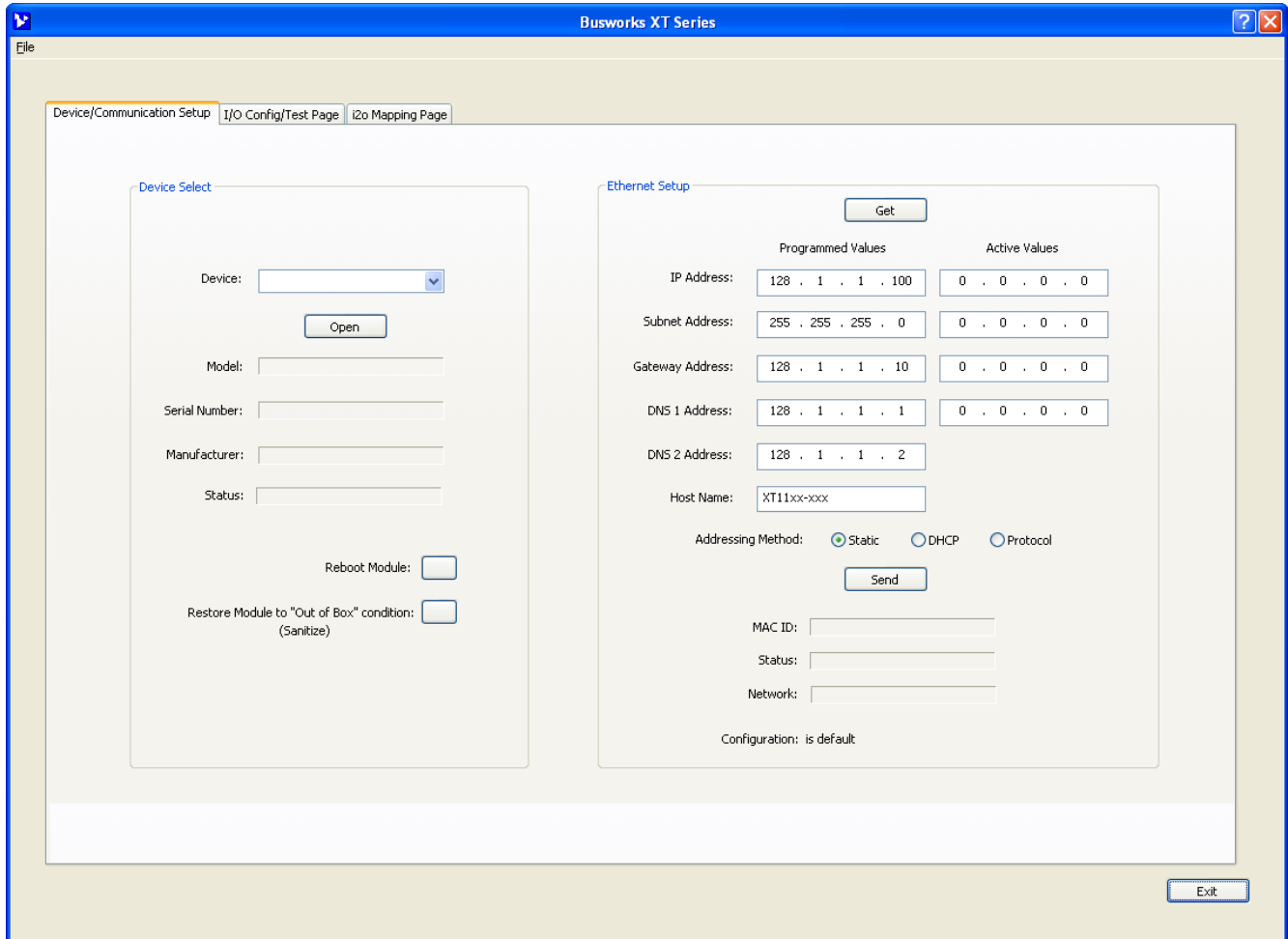

Connect your PC to the unit via USB and its model-serial information will appear in the Device field as shown in the screen on the next page.

Device Select

If you are connected to more than one unit via a USB hub, you can use the Device scroll field to select another unit, using the serial information suffix of the Model to discern one unit from another. Be sure to close the connection with a previous unit before connecting to a new unit.

Once you have selected a device, click the **[Open]** button to open communications with the unit.

Note: Click [Open] only after a unit is fully powered-up and has established its network connection (after ~30 seconds following power-up).

After clicking [Open], the selected unit's Model, Serial Number, Manufacturer, and connection status will be displayed as shown on the next page.

Device/Communication Setup...

Device Select

You can use the **[Reboot Module]** button to force a reset of the unit, equivalent to a power-on reset.

You can use the **[Restore Module]** button to restore a module to its initial “out-of-box” configuration.

Ethernet Setup

You can use the **[Get]** button to retrieve the current Ethernet setup of the connected module (sometimes the Active Values fields will indicate zeros and you must click [Get] to retrieve the actual active values).

You use the Ethernet Setup portion of the screen shown above to specify the network communication parameters required to communicate with this module over Ethernet. You may have to consult with your network administrator to complete the contents of this page. The function of these parameters are defined below:

An **IP Address** is a unique identification number for any host (this module) on any TCP/IP network (including the internet). The IP address is made up of four octets (8 bits), each octet having a value between 0-255 (00H-FFH). It is expressed here in decimal form, with a period placed between octets.

The **Subnet Mask** is used to subdivide the host portion of the IP address into two or more subnets. The subnet mask will flag the bits of the IP address that belong to the network address, and the remaining bits that correspond to the host portion of the address. The unique subnet to which an IP address refers to is recovered by performing a bitwise AND operation between the IP address and the mask itself, with the result being the sub-network address.

Device/Communication Setup...

Gateway Address refers to the IP Address of the gateway this module is to cross, if your local area network happens to be isolated or segmented by a gateway. Typically, it is assigned the first host address in the subnet address space. If a gateway is not present, then this field should contain an unused address within the host subnet address range.

NOTE: In order to network your PC with an Acromag module, you may have to consult with your network administrator and either temporarily change your TCP/IP configuration (see TCP/IP Properties of Network Configuration in Windows), or create a separate private network using a second network adapter installed in your PC (recommended). The necessary steps will vary with your operating system. Refer to Acromag Application Note 8500-734 to help accomplish this (located on the CDROM shipped with your module or via download from our web site at www.acromag.com).

The **DNS 1 Address** refers to the IP address of the first Domain Name Server used on this network. A DNS server relates symbolic address names to actual numeric IP addresses, while the DHCP server is responsible for dynamically passing out IP addresses.

The **DNS 2 Address** refers to the IP address of the secondary Domain Name Server used on this network. A DNS server relates symbolic address names to actual numeric IP addresses, while the DHCP server is responsible for dynamically passing out IP addresses.

The **Host Name** is the name to be assigned to this host if its address happens to be assigned dynamically using DHCP.

The **Addressing Method** refers to how this network module will obtain its IP address when connected to its network.

Static addressing is exactly as the name implies—*static*, and represents a unique fixed IP Address that is generally assigned by your service provider or system administrator. The Default static IP address assigned to this module is 192.168.1.100 (refer to product side label).

DHCP (Dynamic Host Configuration Protocol) refers to a protocol for assigning dynamic IP addresses to devices on a network. With dynamic addressing, a device can have a different IP address every time it connects to the network. In some systems, it can even change while it is still connected.

This module can support three different network protocols simply by changing its installed firmware (Modbus TCP/IP, Ethernet IP, or ProfiNet). The Protocol addressing method refers to allowing the particular application protocol specific to this model to set the IP address (Profinet generally requires this).

By default, the module is setup to use **Static IP Addressing and a default Static IP Address of 192.168.1.100**. You can optionally choose to have the IP address assigned dynamically via DHCP, but this will additionally require that you specify a valid Host Name to retrieve the address from. Choosing Protocol gives the application protocol permission to assign the address.

You can click the **[Send]** button to write your Ethernet Setup parameters to the unit once you are done making your selections. This completes any changes made on this page.

The status field will indicate the status of your sent parameters over USB after clicking [Send]. The Network field will indicate the current network connections status as well as the protocol used for this network. The Configuration field will indicate whether the configuration is from an open device, or a default configuration.

You can click the **[Exit]** button in the lower right hand part of this screen to exit the Configuration Software, or simply click on another tab to access another page before exiting this software.

I/O Configuration & Test Page

Click the “I/O Config/Test Page” tab of the Configuration Software and the screen below will be displayed:

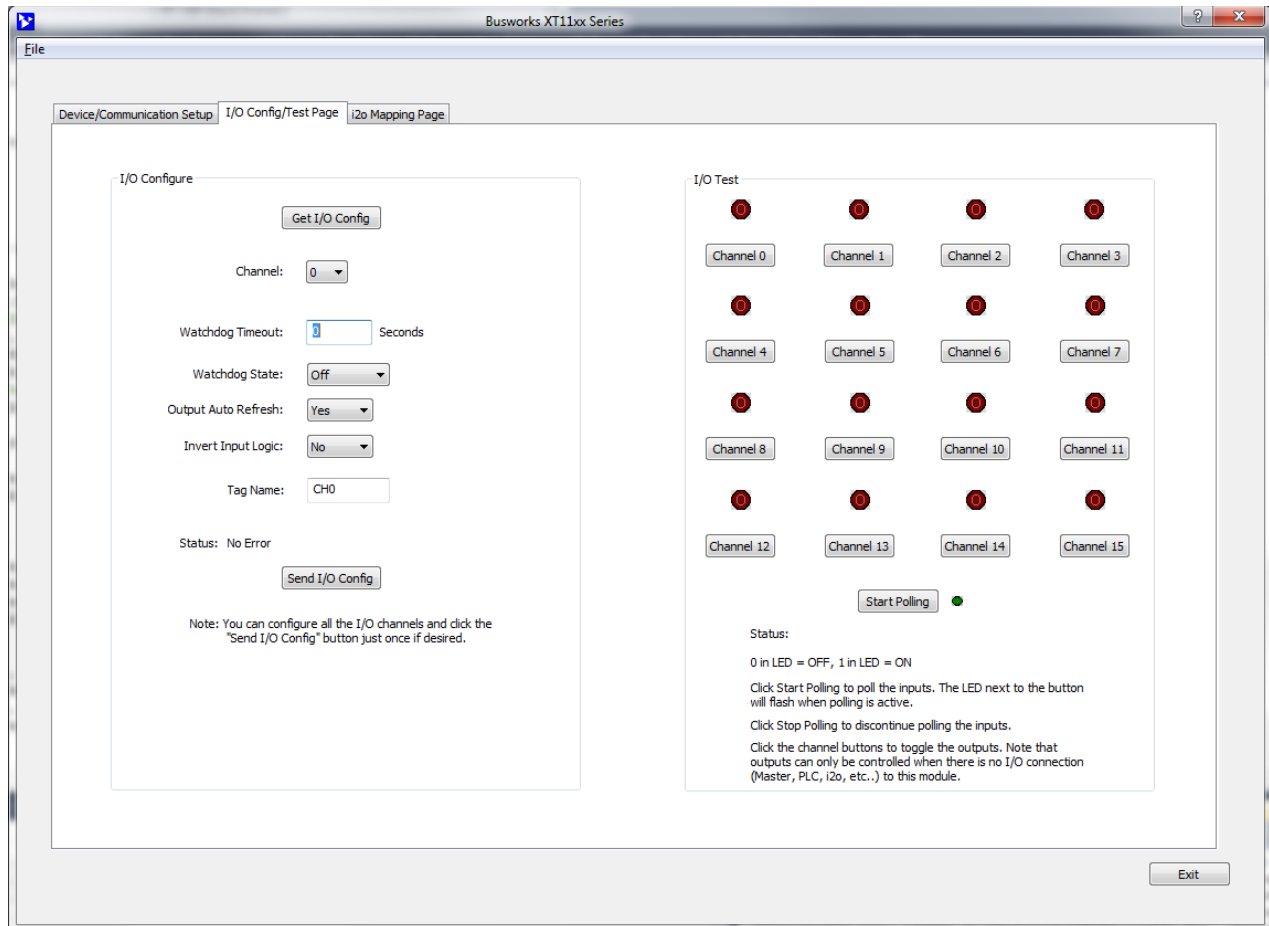

This page allows you to configure each channel of the unit, and optionally Test your I/O configuration to verify functionality.

I/O Configure

Get I/O Config Button: Click this button to retrieve the entire I/O configuration of the module.

Channel: Use the channel scroll bar to select the DIO channel you wish to configure. This model has 16 discrete DIO channels and you can configure each individually.

Watchdog Timeout: Specify a time from 1 to 65534 seconds. A time of 0 or 65535 will disable the channel’s watchdog timer. If no channel read or write activity occurs during this period, a watchdog timeout will be triggered and the channel will be written to the watchdog state (On or Off) you specify in the next field.

Watchdog State: This is the state that you want the output to go to following a watchdog timeout.

Output Auto-Refresh: You can specify that outputs should be rewritten periodically to ensure they maintain their programmed state following a digital upset, perhaps by some extraordinary transient event. This is also useful to reset an output that may be in a latched thermal shutdown following overload conditions.

I/O Configure...continued

Invert Input Logic: Note that this model has active-low inputs, but you can choose to apply an inverter to your input channel by selecting “Yes” here. This will invert the fieldbus data for the input of this model as well as its optional i2o data. For example, if you are using i2o to send this unit’s input information to the output of another unit, or its complimentary active-high XT1121-000 unit, and you wish to invert the ON state logic sent to the target device. This only applies to the input logic of this model, not its output control logic, as setting an output to “1” always turns it ON regardless of this option setting.

Tag Name (up to 8 characters): You can give this I/O channel a name to document its purpose if desired. This is not used by the firmware and just serves as a convenient label for discerning its I/O function or application.

Status: This field displays status messages relative to sending and receiving I/O parameters to the module.

Send I/O Config Button: Click this button to send the entire I/O configuration to the device. Do this one time after you have setup all the I/O channels individually.

I/O Test

This portion of the screen allows you to selectively turn outputs on or off and read the current state of the tandem inputs. Each channel has a simulated LED lamp that flashes and displays “1” when the corresponding output is ON, and is solid dark red and displays “0” when it is OFF. LED state indication accurately reflects the actual state of the output drain as it utilizes the tandem input channel to read back the drain state. Optionally, for simple input monitoring of field inputs (with corresponding output OFF), you can click the [Start Polling] button to periodically read the digital input states.

IMPORTANT: The open drain outputs of this model include tandem input channels that monitor the state of the drain. If your intent is to monitor inputs from the field, you must turn the corresponding output OFF, or you may generate contention between the field signal and the channel output when it is ON. Note that all DIO channels have 10KΩ pull-ups to Excitation and you must connect I/O Excitation to operate the outputs.

Channel Button (Toggle): Click this button to toggle the corresponding DIO channel output ON or OFF.

Start Polling Button (Toggle): Click this button to Start/Stop periodic polling of the DIO input channels. Their states are indicated in the simulated lamp color and the contained “0” indication for OFF, “or 1” indication for ON (assuming that the Invert Input Logic function is set to “No” or disabled).

HELP – You can press [F1] for Help on a selected or highlighted field or control.

i2o Mapping Page

Click the “i2o Mapping Page” tab of the Configuration Software and the screen below will be displayed:

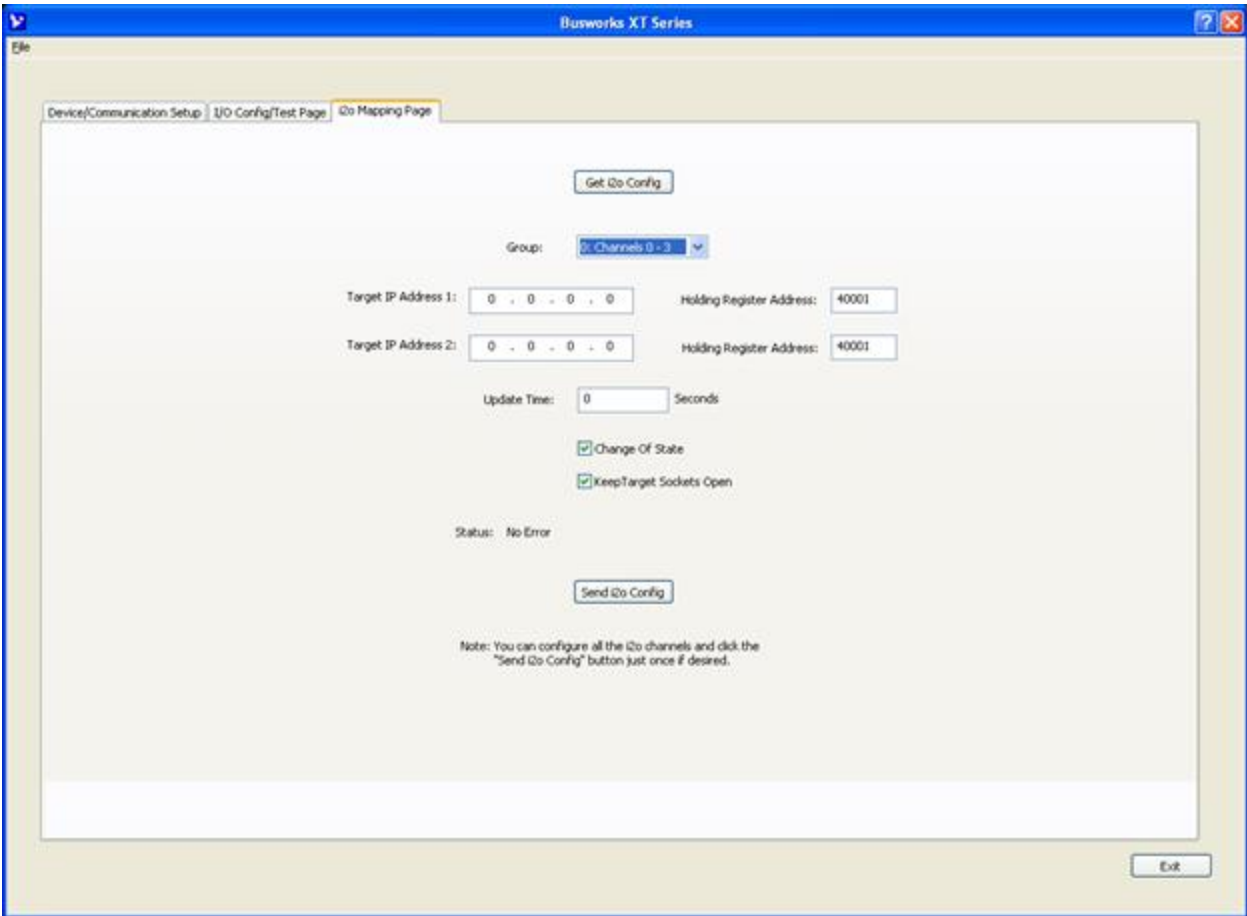

This model includes a special remote messaging function called i2o, for input-to-output communication. This capability allows it to send its digital input information (or its inverted digital input information) over the network to digital outputs on an identical unit, or another compatible unit (like the XT1121-000). The i2o Mapping Page shown above is used to setup i2o by specifying the IP address of the target module (output) to send input channel data to, either upon change-of-state, or cyclically at the update time specified.

IMPORTANT: i2o refers to an Acromag proprietary method of input-to-output communication, done over the network, without other hard-wired connections between inputs and outputs. This is not a Modbus TCP/IP function and the i2o mapping feature of this model may only be configured via this software. As such, there are no Modbus registers for specifying i2o parameters. Under normal operation, this module is designed to function as a Modbus TCP/IP slave/server. By the Modbus standard, Modbus servers are not allowed to initiate messages on their own and may only respond to client/master requests. Thus, the i2o functionality of this unit is a special application that may cause confusion for some other master/client devices linked to the same network. In any case, other master devices on a network should be restricted from attempting to control i2o target devices on the same network to avoid contention.

i2o Mapping Page...

With i2o, a client-server network connection is established between a sending-module (client) and a target output module (server). This connection refers to an established data path, or socket, between the client input device and server output—it does not refer to just the physical network connection between devices. It is similar to other client-server network connections that are created for the exchange of data between devices, such as that between a Modbus Master and slave, or that between a networked PLC, HMI, or other client device and its target server module.

This model has 16 DIO channels, or four groups of 4 digital I/O channels. Group 1 refers to digital I/O channels 0, 1, 2, and 3. Group 2 refers to digital I/O channels 4, 5, 6, and 7. Group 3 refers to digital I/O channels 8, 9, 10, and 11. Group 4 refers to digital I/O channels 12, 13, 14, and 15. Each group of 4 input channels may be mapped to a corresponding group of 4 output channels on another XT1111-000 unit, or compatible unit (like XT1121-000). The digital input data of this unit may be sent cyclically according to an update time, and/or upon change of state.

You can choose to maintain this connection by enabling Keep Socket Open, or to open and close the connection for each i2o message. If Keep Socket Open is disabled, then you should specify an i2o Update Time at the client that is less than the watchdog time of the server, to ensure that the server’s output watchdog does not time-out during the period between i2o updates. Thus, it is generally recommended that you Keep Sockets Open, except perhaps where it costs you money to maintain an open connection, or if infrequent i2o messages might cause your server’s watchdog timer to timeout.

The i2o messaging function works best if the target module(s) are already online and ready to receive messages. However, it will still work if the target output module comes online after the input module, but may take several minutes to “discover” the network targets and begin transmitting to them. If this input module or the target module(s) go offline, remote i2o messaging will resume on its own when the connection is re-established, but this “healing” function may take several minutes depending on which device(s) went offline, why, and for how long.

It is not recommended to set an i2o update rate greater than 99 seconds while also choosing to “Keep Sockets Open”, as increasing bandwidth and shortening response times is not a concern when cyclical messages are spaced farther than 99 seconds apart. But be conservative when setting an update time—shorter intervals than needed may unnecessarily increase network traffic and longer intervals will conserve network bandwidth. Note that digital inputs only map externally to digital outputs of other target modules at different IP addresses, and inputs are mapped in groups of four, to output channels of the target device in groups of four, in the same order. Each i2o message will write at least 4 channels at a time.

To summarize, the behavior of i2o is controlled by the configuration of Update Time, Change-of-State, and Keep Target Sockets Open as illustrated in the following example combinations:

Update Time	Change-of-State	Keep Target Sockets Open	Behavior
0	Disabled	Enabled	i2o is OFF and no i2o messages are sent
0	Disabled	Disabled	i2o is OFF and no i2o messages are sent
0	Enabled	Enabled	Inputs sent every Change-Of-State (COS)
5-99sec	Enabled	Enabled	Inputs sent every COS AND at every interval of time
5-99sec	Disabled	Enabled	Faster throughput w/Inputs sent every interval of update time
0	Enabled	Disabled	Inputs sent only upon a Change-Of-State
5-65535sec	Disabled	Disabled	Inputs sent every interval of Update Time
5-65535sec	Enabled	Disabled	Inputs sent every COS AND at every interval of time
T > 99sec	Disabled	Enabled	Invalid Configuration w/ a long time over an open socket. This will work but it is not recommended to keep the socket open for infrequent i2o updates.

i2o Mapping Page...

Each input group of this device may be mapped to a channel group of another Acromag XT1111-000 or XT1121-000 digital I/O module at one or two different IP addresses. Subsequent messages will be sent at a periodic rate specified by the update time. Note that the target output port channels may still be controlled independently via the network, but their state will be overwritten by subsequent mapped messages when enabled. It is recommended that you do not control the i2o mapped output ports (target channels) directly, as this could create contention with the i2o control. You cannot use the USB software to control the state of outputs that are i2o targets.

Group Scroll Bar: Select consecutive groups of 4 input channels, each to be mapped to 4 output channels of another unit, in the same order, at the Holding Register address specified. You can configure each group separately.

Target IP Address 1 & Target IP Address 2: This is the IP Address of one or two target output devices (another XT1111-000 or XT1121-000 module on the network). Each digital input group can only be mapped to an output group at one or two target IP addresses.

Holding Register Address 1 & 2: This is the Memory Map address of the output channel group (4 channels) of your i2o target to send this units input data to.

Update Time Field: Specify a time of 0, or from 5-65534 seconds between messages. Specify 0 to turn i2o messaging OFF (cyclical). If change-of-state is enabled and a time greater than or equal to 5 is specified, your message will be sent both upon change of state and at the update time specified.

Change-of-State Checkbox: Set ON to enable output updates on change of input state, and OFF to update cyclically according to the update time.

Keep Target Sockets Open Checkbox: Check this box to keep the communication socket of the target device open after sending i2o data. Keeping the socket open is helpful to obtain a faster i2o throughput time, as the open and close socket messages are not required for each message, allowing an i2o message to be sent immediately along an already open socket. But you should not keep the socket open if you do not require frequent updates, as it does limit the bandwidth somewhat. For wireless/cellular systems, or peer-to-peer applications with long intervals between update messages, you may consider unchecking this box. While still possible, do not Keep Sockets Open and set update intervals greater than 99 seconds (infrequent messaging with long i2o intervals does not need to keep the socket open).

Status Field (USB): Gives the status of your USB i2o configuration message (i.e. returns the status of the write or read of the i2o configuration info only).

Get i2o Config Button: Click this button to retrieve the current i2o configuration from the unit. See the Status field for the status of this operation.

Send i2o Config Button: Click this button to write your i2o configuration to the unit. You may click **[Send i2o Config]** for each group, one at a time, or you can step through all i2o channels and then click the **[Send i2o Config]** button one time to write your entire i2o configuration. See the Status field for the status of this operation.

Network Home Page

After you have configured your unit for network communications via its USB connection, you can identify the unit on the Ethernet network using a web browser directed to its IP address (you set this address, the default is 192.168.1.100). This will access the home page of the unit similar to the first screen shown on the following page. You can click the "Communication Parameters" link of the Home Page to access the Ethernet Connection Status page shown in the second screen, useful for verifying your network connection to the unit and its corresponding communication parameter settings.

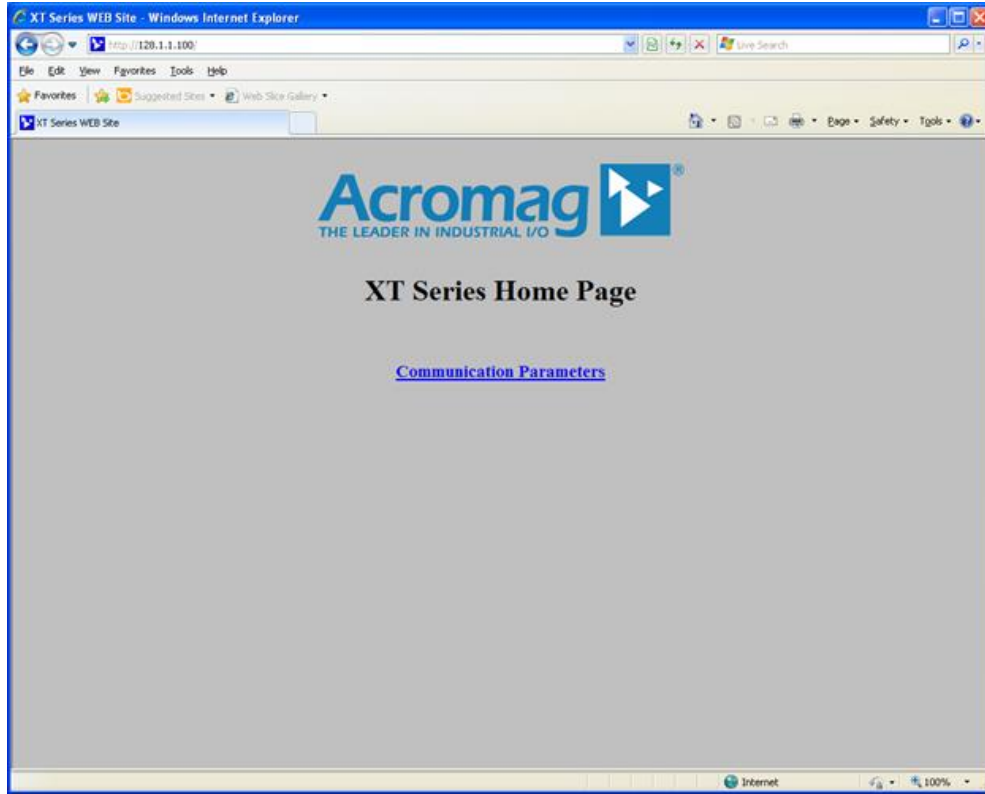

BLOCK DIAGRAM

XT111x-000 SIMPLIFIED SCHEMATIC (FILTERING AND DETAIL OMITTED FOR CLARITY)

DO NOT ALLOW EXCITATION OR UNUSED INPUTS TO FLOAT. A CONNECTION TO EXC IS NEEDED SO THAT TANDEM INPUT READS BACK PROPERLY AND DOES NOT FLOAT WHEN SWITCH IS OFF.

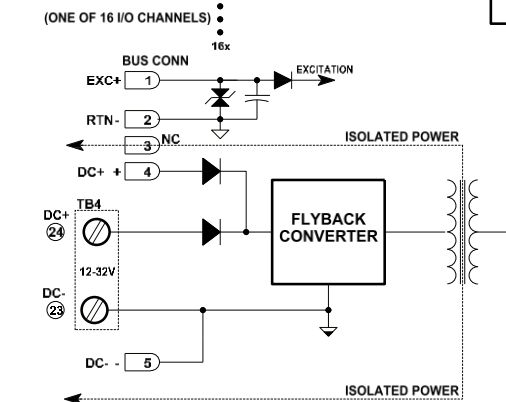
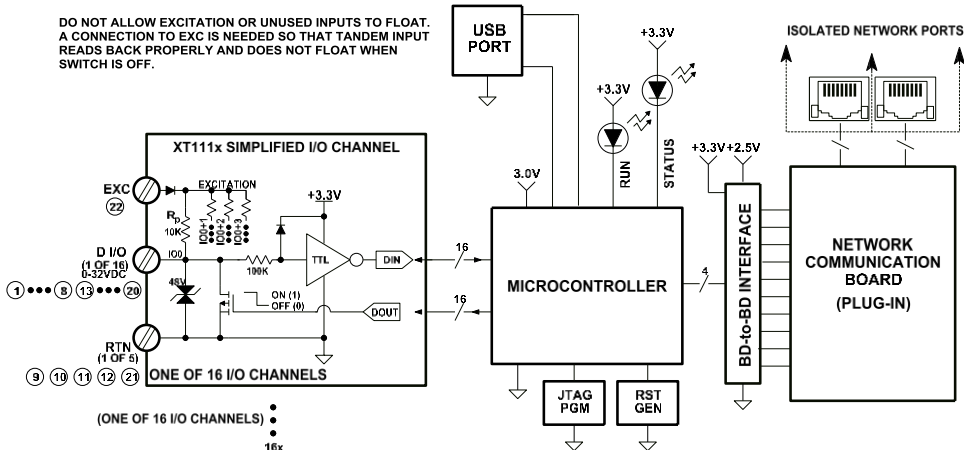

OUTPUT CHANNELS AND INPUT CHANNELS CONNECT IN TANDEM. OUTPUTS ARE OPEN-DRAIN MOSFET SWITCHES w/10K PULLUPS TO EXC. INPUTS ARE BUFFERED AND USE TTL THRESHOLDS. POWER AND NETWORK CONNECTIONS ARE ISOLATED. CONNECT EXCITATION TO PROPERLY REGISTER INPUTS WHEN TANDEM OUTPUTS ARE OFF, AND TO KEEP UNUSED INPUTS FROM FLOATING

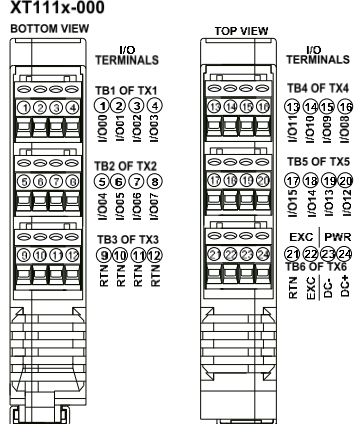

How It Works

Key Points of Operation

- Unit is DC Powered
- I/O & USB are Isolated from the network and input power.
- Outputs are connected in tandem with corresponding inputs.
- Inputs use TTL Logic Levels
- Outputs are Open-Drain, n-channel, low-side switches.
- I/O channels are individually pulled up to the excitation rail.
- I/O circuit return is common to USB ground.

This model has 16 smart low-side mosfet switches controlled by a 32-bit microcontroller. Switches are the open-drains of N-channel mosfets and sink load current to return. Each drain is pulled up to the I/O excitation supply rail via a 10KΩ pull-up resistor and is fed back to the controller through a 100KΩ series resistor driving an inverting input buffer with its input diode clamped to its +3.3V rail, allowing input voltages well above its rail. Input transitions use TTL logic thresholds and feed the actual state of the tandem drain back, or an input state from the field when its tandem output turned OFF. Network communication specific to Modbus TCP/IP is handled by a separate controller on a mating communication board, serial-uart linked to the I/O board. Power for the I/O and network circuits is provided via an isolated fly-back converter on the I/O board that operates from 12-32VDC. The unit is setup for network operation via a USB connection between a host PC and the microcontroller of the I/O board. The host PC runs model specific configuration software designed for the XT. Refer to the block diagram above to gain a better understanding of how this model works.

How it Works...

The I/O & USB, network, and input power circuits are isolated from each other. The USB port ground is common to the I/O circuit return. The USB port ground of most PC's is also common to the USB cable shield and earth ground. I/O signals could be grounded or ungrounded. For this reason, it is recommended that USB signals be isolated when connected to a PC to prevent a ground loop from occurring between the PC earth ground and a grounded input signal, which could have the negative affect of driving a digital upset for severe ground loop currents.

About Modbus TCP/IP

TCP/IP refers to Transmission Control Protocol and Internet Protocol. TCP/IP allows blocks of binary data to be exchanged between computers. TCP/IP is used world-wide and is the foundation for the World Wide Web. The primary function of TCP is to ensure that all packets of data are received correctly, while IP makes sure that messages are correctly addressed and routed. Note that the TCP/IP combination does not define what the data means or how the data is to be interpreted, it is merely a *transport protocol*. Modbus operates on the actual data for this model.

You can find more information on Modbus TCP/IP by visiting our web site and downloading whitepaper 8500-765, Introduction To Modbus TCP/IP.

Modbus is an *application protocol*. It defines rules for organizing and interpreting data and is essentially a messaging structure that is independent of the underlying physical layer. It is freely available and accessible to anyone, easy to understand, and widely supported by many manufacturers.

Modbus TCP/IP uses TCP/IP and Ethernet to carry the data of the Modbus message structure between devices. That is, Modbus TCP/IP combines a physical network (Ethernet), with a networking standard (TCP/IP), and a standard method of representing data (Modbus). A Modbus TCP/IP message is simply a Modbus communication encapsulated in an Ethernet TCP/IP wrapper.

In practice, Modbus TCP embeds a Modbus data frame into a TCP frame, sans the Modbus checksum, as shown in the following diagram. The Modbus checksum is not used, as the standard Ethernet TCP/IP link layer checksum methods are instead used to guaranty data integrity.

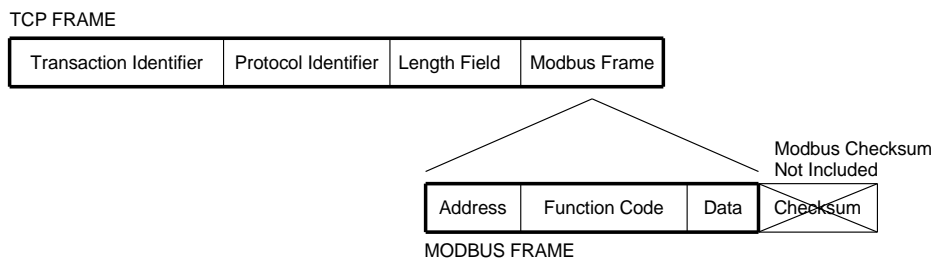

Note that the Modbus address field is referred to as the *Unit Identifier* in Modbus TCP. In a typical slave application, the Unit ID is ignored and just echoed back in the response.

About Modbus TCP/IP...

The operation over Ethernet is essentially transparent to the Modbus register/command structure. If you are already familiar with Modbus or with the Acromag Series 900MB Modbus modules, then you are already familiar with the operation of these modules over Ethernet.

IP Addressing

A *Static IP Address* is as the name implies—static. That is, it is a unique IP Address that is assigned by a service provider and never changes.

A *Dynamic IP Address* is an address that is temporarily assigned to a user by a service provider each time a user connects.

A *Subnet* is a contiguous string of IP addresses. The first IP address in a subnet is used to identify the subnet, while the last IP address in a subnet is always used as a broadcast address. Anything sent to the last IP address of a subnet is sent to every host on that particular subnet.

Subnets are further broken down into three size classes based on the 4 octets that make up the IP address. A Class A subnet is any subnet that shares the first octet of the IP address. The remaining 3 octets of a Class A subnet will define up to 16,777,214 possible IP addresses ($2^{24} - 2$). A Class B subnet shares the first two octets of an IP address (providing $2^{16} - 2$, or 65534 possible IP addresses). Class C subnets share the first 3 octets of an IP address, giving 254 possible IP addresses. Recall that the first and last IP addresses are always used as a network number and broadcast address respectively, and this is why we subtract 2 from the total possible unique addresses that are defined via the remaining octet(s).

TIP: The first node (0), node 10, and the last node (255 for our example) are typically reserved for servers and may yield poor results if used.

For our example, the default IP address of this module is 192.168.1.100. If we assume that this is a Class C network address (based on a default Class C subnet mask of 255.255.255.0), then the first three numbers represent this Class C network at address 128.1.1.0, the last number identifies a unique host/node on this network (node 100) at address 192.168.1.100.

A *Subnet Mask* is used to determine which subnet an IP address belongs to. The use of a subnet mask allows the network administrator to further divide the host part of this address into two or more subnets. The subnet mask flags the network address portion of the IP address, plus the bits of the host part that are used for identifying the sub-network. By convention, the bits of the mask that correspond to the sub-network address are all set to 1's (it would also work if the bits were set exactly as in the network address). It's called a mask because it can be used to identify the unique subnet to which an IP address belongs to by performing a bitwise AND operation between the mask itself, and the IP address, with the result being the sub-network address, and the remaining bits the host or node address.

IP Addressing...

For our Example, if we wish to further divide this network into 14 subnets, then the first 4 bits of the host address will be required to identify the sub-network (0110), then we would use "11111111.11111111.11111111. 11110000" as our subnet mask. This would effectively subdivide our Class C network into 14 sub-networks of up to 14 possible nodes each.

With respect to the default settings of this module:

Subnet Mask 255.255.255.0 (11111111.11111111.11111111.00000000)

IP Address: 192.168.1.100 (10000000.00000001.00000001.01100100)

Subnet Address: 128.1.1.0 (1000000.00000001.00000001.00000000)

The sub-network address of 128.1.1.0 has 254 possible unique node addresses (we are using node 100 of 254 possible as our default). Nodes 0, 10, and 255 are typically reserved for servers and may yield poor results if used.

Dynamic Host Configuration Protocol (DHCP)

DHCP refers to Dynamic Host Configuration Protocol and is a method used to assign temporary numeric IP addresses as required. A DHCP server maintains a pool of shared IP addresses which are dynamically assigned and recycled. When a DHCP device wants to use a TCP/IP application, it must request an IP address from the DHCP server. The DHCP server will check the shared supply, and if all addresses are in use, the server will send a busy signal to the client which tells it to try again later. Static IP addresses will ensure a connection every time, but dynamic addresses do not.

Domain Name System (DNS)

DNS refers to the Domain Name System or Domain Name Server and refers to the system used to associate an alphanumeric character string with a numeric IP address. The DNS is a distributed database of domain names and corresponding IP addresses. DNS servers contain information on some segment of the domain name space and make this information available to clients called *resolvers*. For example, the DNS allows us to use "Acromag.com" as an IP address rather than a complicated number string.

MODBUS REGISTERS

Modbus registers are organized into different reference types identified by the leading number of the reference address:

Reference	Description
0xxxx	<u>Read/Write Discrete Outputs or Coils</u> . A 0x reference address is used to drive output data to a digital output channel.
1xxxx	<u>Read Discrete Inputs</u> . The ON/OFF status of a 1x reference address is controlled by the corresponding digital input channel.
3xxxx	<u>Read Input Registers</u> . A 3x reference register contains a 16-bit number received from an external source—e.g. an analog signal.
4xxxx	<u>Read/Write Output or Holding Registers</u> . A 4x register is used to store 16-bits of numerical data (binary or decimal), or to send the data from the CPU to an output channel.

The “Reference” leading character indicated above is generally implied by the function code and omitted from the address specifier for a given function. The leading character also identifies the I/O data type. The “x” following the leading character represents a four-digit address location in user data memory.

Note: The ON/OFF state of discrete inputs and outputs is represented by a 1 or 0 value assigned to an individual bit in a 16-bit data word. This is sixteen 0x or 1x references per data word. With respect to mapping, the LSB of the word maps to the lowest numbered channel of a group and channel numbers increase sequentially as you move towards the MSB. Unused bit positions are set to zero.

All I/O values are accessed via the 16-bit Input Registers or 16-bit Holding Registers given in the Register Map. Input registers contain information that is read-only. For example, the current input value read from a channel, or the states of a group of digital inputs. Holding registers contain read/write information that may be configuration data or output data. For example, the high limit value of an alarm function operating at an input, or an output value for an output channel.

Register Functions

For detailed information on Modbus, feel free to download our technical reference 8500-648, "Introduction To Modbus", at www.acromag.com. You can also find more information specific to Modbus TCP/IP by down-loading whitepaper 8500-765, "Introduction To Modbus TCP/IP".

Each module has a default factory configuration as noted in the SPECIFICATIONS section. Your application will likely differ from the default configuration and the module will need to be reconfigured for your application. You may only reconfigure this module using a USB connection to it and running Acromag Configuration Software. There are no Modbus commands for setting configuration parameters, as they are only setup through a USB connection to a Windows based host PC.

Below is a small subset of standard Modbus functions that are supported by this module along with the reference register address group that the function operates on. Use these functions to access these registers as outlined in the Register Map for sending and retrieving data.

The following Modbus functions operate on register map registers to monitor, configure, and control module I/O:

CODE	FUNCTION	REFERENCE
03 (03H)	Read Holding Registers	4xxxx
04 (04H)	Read Input Registers	3xxxx
06 (06H)	Preset Single Register	4xxxx
16 (10H)	Preset Multiple Registers	4xxxx
17 (11H)	Report Slave ID (See Below)	Hidden Function

If an unsupported function code is sent to a module, exception code 01 (Illegal Function) will be returned in the response. If a holding register is written with an invalid value, exception code 03 (Illegal Data Value) will be returned in the response message. You may refer to the Modbus specification for a complete list of possible error codes.

Note that register mirroring is not supported in the Series XT models.

XT1111-000 Report Slave ID Example Response¹

FIELD	DESCRIPTION
Unit ID	Echo Unit ID Sent In Query
Function Code	11
Byte Count	30
Slave ID (Model No.) ¹	1=XT1111-000 (16 DI/O Sinking)
Run Indicator Status	FFH (ON)
Firmware Number String (Additional Data Field) ¹	41 63 72 6F 6D 61 67 2C 58 54 31 31 31 31 2D 78 78 78 2C 39 33 30 30 2D 32 31 36 ("Acromag,XT1111-xxx,9300-216")

¹Note: The XT1111-000 slave ID is "1" and the firmware number is 9300-216.

Data Types

I/O values for this model are generally indicated by a single bit of a 16-bit word for discrete on/off control or indication, except for watchdog time, which uses an unsigned integer value in range of 0-65535. For discrete I/O, the bit number/position typically corresponds to the discrete channel number for this model. Unless otherwise defined for outputs, a 1 bit means the corresponding output is closed or ON, a 0 bit means the output is open or OFF. For inputs of this model, a value of 1 means the input is ON (Active-low < 0.8V), while a value of 0 specifies the input is OFF or in its high state (asserted high > 2.0V). This is the logic assuming the Invert Input Logic function is set to “No” or disabled.

Register Map

The table at right outlines the register map for the Model XT1111-000 network I/O module. It is very similar to its complimentary XT1121-000 model with active-high, sourcing outputs.

Note the memory map for these models only covers I/O data, as all reconfiguration is done via USB prior to connecting to the network.

Modbus functions operate on these registers using the data types noted above (except for the Report Slave ID functions).

Unless otherwise noted, Holding Register values are maintained in non-volatile flash memory.

Ref.	Addr.	Description	Data Type/Format
Input Registers (3x References, Read-Only)			
30001	0 (0000)	Input State for Group 0 (Channels 0-3)	Bit 15-4: 0 (Not Used) Bit 3: CH3 Bit 2: CH2 Bit 1: CH1 Bit 0: CH0 1 = ON or Low (Active-Low Input, Asserted < 0.8V) 0 = OFF or High (Input > 2.0V) A set bit (1) means the input is ON or asserted low. A clear bit (0) means the input is OFF or asserted high. Additionally, unused bits are set to 0. <u>This applies with the Invert Input Logic switch set to “No” (standard logic).</u>
Note: The 30001-30004 registers reflect the actual state of the corresponding input signal, or the drain of the tandem output. This signal is active-low. Failure to provide excitation will leave inputs floating.			

Register Map...

There are no registers for setting configuration variables, as this model is only configured via USB using its Configuration Software running on a Windows based Personal Computer. Configuration should be done prior to connecting to the network.

It is possible that the input state indicated may not reflect the actual state of the tandem output if the I/O channel is experiencing contention between via a field signal and an output that happens to be turned ON. If monitoring field signals, the corresponding tandem output must be turned OFF to avoid this contention between the output channel and the field signal.

Ref.	Addr.	Description	Data Type/Format
Input Registers (3x References, Read-Only)			
30002	0001	Input State for Group 1 (Channels 4-7)	<u>Bit 15-4</u> : 0 (Not Used) <u>Bit 3</u> : CH7 <u>Bit 2</u> : CH6 <u>Bit 1</u> : CH5 <u>Bit 0</u> : CH4 1 = ON or Low (Active-Low Input ≤ 0.8V) 0 = OFF or High (Input ≥ 2.0V) <u>This applies with the Invert Input Logic switch set to "No" (standard logic).</u>
30003	0002	Input State for Group 2 (Channels 8-11)	<u>Bit 15-4</u> : 0 (Not Used) <u>Bit 3</u> : CH11 <u>Bit 2</u> : CH10 <u>Bit 1</u> : CH9 <u>Bit 0</u> : CH8 1 = ON or Low (Active-Low Input ≤ 0.8V) 0 = OFF or High (Input ≥ 2.0V) <u>This applies with the Invert Input Logic switch set to "No" (standard logic).</u>
30004	0003	Input State for Group 3 (Channels 12-15)	<u>Bit 15-4</u> : 0 (Not Used) <u>Bit 3</u> : CH15 <u>Bit 2</u> : CH14 <u>Bit 1</u> : CH13 <u>Bit 0</u> : CH12 1 = ON or Low (Active-Low Input ≤ 0.8V) 0 = OFF or High (Input ≥ 2.0V) <u>This applies with the Invert Input Logic switch set to "No" (standard logic).</u>
30005	0004	Heart Beat Register	An integer counter that increments by 1 for every host to network data transfer to help indicate if fresh data is present relative to the last transfer, or if the unit has halted for some reason. This register counts from 0 to 65535 and wraps back around to 0.

Register Map...

Note: A watchdog timeout is triggered if an established client-server relationship to the module is severed by a cable break or power disruption at the client. A client-server network connection to the module is created for the exchange of data between devices, such as that between a Modbus Master and slave, or that between a networked PLC, HMI, or other client device and its target server module. Thus, a watchdog timeout can only be cleared at the server by first restoring the broken client-server relationship. Clearing a timeout by restoring the client-server connection to the module does not return output(s) to their initial "pre-timeout" state and they remain in their timeout states until otherwise written via the holding registers, or via Output Auto Refresh.

Note: The holding register signal corresponds to the gate signal of the n-channel output mosfet. The bit position corresponds to the output channel number (i.e. output 0 uses bit 0 of the 16-bit word at address 0, output 1 uses bit 1 of the 16-bit word at address 1, etc.) A set bit (1) means the output is turned ON (sinking current). A clear bit (0) means output is turned OFF (open). Excitation must be provided in order to operate the outputs. A read of this register may not reflect the actual output level at the drain of the mosfet if the open-drain is not pulled up or is left floating. You can read the Input Registers to obtain the actual output drain state(s) via closed loop feedback.

Ref.	Address	Description	Data Type/Format
Holding Registers (4x References, Read/Write)			
40001	0 (0000)	Set Output State for Group 0 (Channels 0-3)	Bit 15-4: 0 (Not Used) Bit 3: CH3 Bit 2: CH2 Bit 1: CH1 Bit 0: CH0 1 = Turn Output ON (Closed) 0 = Turn Output OFF (Open) Setting the bit to 1 will drive the corresponding output to be switched ON (conduct or sink current to return). Clearing the bit to 0 means the output will be switched OFF (open). Unused bits are set to 0. The Invert Input Logic function does not affect output logic control or indication, it only affects the logic of the tandem input channel.
<p>Note: The outputs of this model are the open drains of n-channel mosfet switches with their source leads held in common at return (RTN). Outputs are pulled up to the Excitation voltage via 10KΩ resistors.</p> <p>The 40001-40004 registers are used to set/clear the output state of the corresponding output channel and will trigger the gate of the output mosfet to turn ON or OFF as required. Output channels conduct from output to RTN when turned ON. Failure to provide excitation will leave the open-drain outputs floating.</p>			
40002	1 (0001)	Set Output State for Group 1 (Channels 4-7)	Bit 15-4: 0 (Not Used) Bit 3: CH7 Bit 2: CH6 Bit 1: CH5 Bit 0: CH4 1 = Turn Output ON (Closed) 0 = Turn Output OFF (Open)
40003	2 (0002)	Set Output State for Group 2 (Channels 8-11)	Bit 15-4: 0 (Not Used) Bit 3: CH11 Bit 2: CH10 Bit 1: CH9 Bit 0: CH8 1 = Turn Output ON (Closed) 0 = Turn Output OFF (Open)
40004	3 (0003)	Set Output State for Group 3 (Channels 12-15)	Bit 15-4: 0 (Not Used) Bit 3: CH15 Bit 2: CH14 Bit 1: CH13 Bit 0: CH12 1 = Turn Output ON (Closed) 0 = Turn Output OFF (Open)
<p>After reset, these registers read 0 (outputs OFF) and the contents of the output registers are not maintained in non-volatile memory.</p>			

TROUBLESHOOTING

Diagnosics Table

Before attempting repair or replacement, be sure that all installation and configuration procedures have been followed and that the unit is wired properly. Verify that 12-32V power is applied to the unit. Try rebooting the module.

If your problem still exists after checking your wiring and reviewing this information, or if other evidence points to another problem with the unit, an effective and convenient fault diagnosis method is to exchange the questionable unit with a known good unit.

Acromag's Application Engineers can provide further technical assistance if required. Repair services are also available from Acromag.

POSSIBLE CAUSE	POSSIBLE FIX
<i>Green RUN LED does not light...</i>	
Internal +3.3V has failed.	Return module for repair.
<i>Green RUN LED flashes continuously...</i>	
Network Cable or Network Board Problem	This LED flashes during initialization, startup, and reconfiguration, but if it flashes continuously, then it means that the network board could not initialize, which can be driven by an unplugged or defective network cable. If network cable & connection are good, then you should return the module for repair or reprogramming.
<i>Cannot Communicate with Module Over Network...</i>	
Power ON at Module?	Check power. Is Green Run LED ON?
Using Wrong IP Address	You must change either the IP address of the module or your host PC network card so that they match subnets.
<i>Cannot Communicate with Module via USB...</i>	
A missing USB Isolator could cause a ground loop between a grounded input signal and earth ground at the connected Personal Computer's USB port.	Without a USB isolator, a ground loop is created between a grounded input signal source and earth ground of the PC USB port. For this reason, and for increased safety and noise immunity, it's best to connect to USB via a USB isolator. Use an isolator like the Acromag USB-ISOLATOR. Otherwise, use a battery powered laptop to configure the module which does not normally earth ground its USB port.
<i>Software Fails to Detect Module...</i>	
Bad USB Connection	Recheck USB Cable Connection
USB has not enumerated the device.	Use the reset button of the Acromag USB isolator to trigger reenumeration of the module, or unplug/replug the USB cable to the module.
Communication/power was lost while USB was connected and the configuration software was running.	Close the current connection with the software, then select and re-open the module for communication (or simply exit the Configuration software and reboot it).
<i>Digital Inputs Register Incorrect State...</i>	
There is contention between the field input signal and the tandem open-drain output which may be ON, or the Invert Input Logic function may be enabled.	If you are monitoring a field digital input, you must turn the channel's corresponding output OFF. Check the state of the Invert Input Logic function.

Diagnostics Table...

POSSIBLE CAUSE	POSSIBLE FIX
<i>I/O is Erratic, Not operational, or Intermittent when Connected to USB...</i>	
Missing USB isolation with grounded I/O signal source.	Even though the I/O is isolated from the network and power, if your input signal is already earth grounded, then connecting USB to the module may drive a ground loop between your input and earth ground at the PC. Use USB signal isolation, or alternatively, you can connect to a battery-powered laptop/PC, which does not earth ground its USB connection.
<i>I/O is not Changing States when toggling OFF/ON...</i>	
Ethernet cable may not be connected properly.	Check your network cable connection to the unit.
<i>Outputs Not Working...</i>	
Missing EXC connection.	Connect EXC to power.
A client-server relationship has been established to this module and is blocking USB control of the outputs.	If a client (Modbus master, PLC, HMI, i2o) has established a connection to this server, then the server's outputs will not be controllable via the configuration software.
<i>Unused Inputs are Changing States...</i>	
Your Excitation is floating.	You must connect I/O excitation between the module's EXC and RTN terminals (22 & 21). If EXC is left floating, then the pull-up resistors of the I/O channels link to adjacent channels via their pull-up resistors common connection to EXC., allowing them to pull one another.
<i>I/O Channels Change States when you connect USB...</i>	
Indicative of a ground fault between earth ground at the PC and earth ground applied at the I/O channels.	Only connect to the unit via isolated USB if your I/O signal is already earth grounded. You can connect without USB isolation if the I/O signal is not already grounded.
<i>Unit fails to operate or exhibits an output shift...</i>	
Is USB isolation not being used with a grounded sensor?	Isolated models are intended for use with ungrounded or grounded sensors, but you can only connect to grounded sensors if the USB signals are also isolated. The input is normally biased 1.25V off input ground to allow negative-going signals. A grounded probe could inadvertently connect this bias to earth ground with a non-isolated USB connection to a PC.
<i>Many Communication Errors...</i>	
Is Cable segment longer than 100M?	The maximum distance between two nodes on an Ethernet network is limited to 100 meters using approved cable.
Correct Cable Type	Shielded CAT-5/5E cable, equivalent or better, is recommended.
Missing Earth Ground Connection?	Connect earth ground to the power minus terminal at TB6-23.

Diagnostics Table...

POSSIBLE CAUSE	POSSIBLE FIX
<i>Status field of software screen indicates "Data Transfer Error", "Unknown Protocol" or "Timeout Error"...</i>	
USB connection was opened before unit had completed its power-on initialization and established its network connection.	Wait ~30 seconds after powering-up unit before opening a USB connection via the configuration software. Turn power off to the unit, close the USB configuration software, repower the unit, then reboot the USB configuration software after unit has completed power-on initialization and established its network connection.
<i>Continuous blinking yellow status LED...</i>	
Watchdog timer has timed out.	In the absence of a client-server relationship over the network, such as that formed with i2o, or between a Modbus master/client and slave/server, a PLC or HMI and a server module, the watchdog will timeout when enabled. It can also timeout if a client-server relationship has been severed by a network cable break, or power disruption at the client.
<i>Enabled watchdog timer never times out, or only times out initially...</i>	
There is an established client-server connection (socket) over the network with this module.	The timer will only time out if a client-server connection has not been established, or has been severed by a cable break.
<i>i2o is not working...</i>	
The upload was corrupted when i2o was written to the module.	Although rare, if you have rechecked your i2o configuration, but it fails to operate, try rebooting the module, or re-writing your i2o configuration (check your address settings, update time, change-of-state, etc).

Service & Repair Assistance

This unit contains solid-state components and requires no maintenance, except for periodic cleaning and module configuration parameter (zero and full-scale) verification. The enclosure is not meant to be opened for access and can be damaged easily if snapped apart. Thus, it is highly recommended that a non-functioning module be returned to Acromag for repair or replacement. Acromag has automated test equipment that thoroughly checks and calibrates the performance of each module, and can restore firmware. Please refer to Acromag's Service Policy and Warranty Bulletins or contact Acromag for complete details on how to obtain repair or replacement.

ACCESSORIES

Software Interface Package

Software Interface Package/Configuration Kit – Order XT-SIP

- USB Signal Isolator
- USB A-B Cable 4001-112
- USB A-mini B Cable 4001-113
- Configuration Software CDROM 5041-094
- Single-shielded Category 5e STP Ethernet Crossover Cable, Green, 5 feet long, with a drain wire and an RJ45 plug at each end.



This kit contains all the essential elements for configuring XT network modules. Isolation is recommended for USB port connections to these models and will block potential ground loops between your PC and grounded I/O signals. A software CDROM is included that contains the Windows software used to program the unit.

USB Isolator



USB Isolator – Order USB-ISOLATOR

- USB Signal Isolator
- USB A-B Cable 4001-112
- Instructions 8500-900

This kit contains a USB isolator and a 1M USB A-B cable for connection to a PC. This isolator and cable are also included in XT-SIP (see above).

USB A-B Cable



USB A-B Cable – Order 4001-112

USB A-B Cable 4001-112 is a 1 meter, USB A-B replacement cable for connection between your PC and the USB isolator. It is normally included with the XT-SIP Software Interface Package and with the isolator model USB-ISOLATOR.

USB A-mini B Cable



USB A-mini B Cable – Order 4001-113

- USB A-mini B Cable 4001-113

This is a 1 meter, USB A-mini B replacement cable for connection between a USB isolator and XT/TT/SP/DT transmitters/splitters. It is normally included in XT-SIP.

End Stops



Two End Stops – Order 4001-252

- Two 1027-222 End Stops for 35 mm DIN Rail mounting

For hazardous location installations (Class I, Division 2 or ATEX Zone 2), you can use two end stops (Acromag 1027-222) to help secure modules to 35mm DIN rail (not shown).

DIN Rail Bus Connector Kit

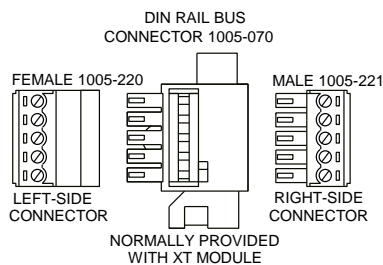

Bus Connector Kit for DIN Rail Bus Connection to Power, Model XTBUS-KIT

- DIN Rail Bus Connector 1005-070 for 22.5mm XT Modules.
- Left Side terminal block, female connector 1005-220.
- Right Side terminal block, male connector 1005-221.
- Two End Stops for 35 mm DIN Rails 1027-222 (not shown).

This module is shipped with the first item included in this kit (DIN Rail Bus Connector 1005-070) and this kit offers a spare. Left and right side terminal blocks mate directly to the bus connector included in this kit and are used to optionally (or redundantly) drive power to Series XT modules via their DIN rail bus connector. They are also used to optionally connect I/O to Excitation along the DIN rail for some XT models (XT111x-000). This allows modules to neatly and conveniently share connections to Power and/or Excitation. Two end stops 1027-222 are used to secure the terminal block and module for hazardous location installations.

Low EMI Double-Shielded Patch Cable

Ethernet Patch Cable, 3 feet long, Model 5035-369

Ethernet Patch Cable, 15 feet long, Model 5035-370



This cable is used to connect a module to your network switch (Acromag 900EN-S005 or equivalent Ethernet switch) and is double-shielded for lower emissions and increased RFI resistance. It has a red, low-smoke, zero halogen jacket and bundles four pairs of 26AWG stranded cable. It uses a 100% foil shield beneath a 60% braided outer shield and includes an RJ45 plug at each end. It is electrically equivalent to L-Com TRD855DSZR cable and can be obtained in other lengths directly from L-Com (<http://www.l-com.com>).

Double-shielded CAT5e or better cable is recommended for very noisy environments or in the presence of strong electrical fields. You may obtain shielded CAT-5e cable in other lengths and colors as required for your application from other vendors including L-com Connectivity Products, www.L-com.com, Pro-Link, www.prolink-cables.com, Regal, www.regalusa.com, and Lumberg, www.lumbergusa.com.

SPECIFICATIONS

Model Number

Model XT1111-000

Digital I/O Module
 Modbus TCP/IP Support
 16 Isolated DC I/O Channels
 DC Powered
 CE Approved
 Includes UL/cUL Class I, Division 2 approvals

The XT1111-000 model denotes a 16-channel digital I/O module with 16 sinking (low-side) switch outputs, and 16 tandem digital inputs, for DC voltage applications only. This model operates over Ethernet using Modbus TCP/IP. It is setup and configured using USB. It represents another member of the Acromag DIN-Rail mounted, "Busworks" family, in the XT Series. Refer to Model XT1121-000 for a complimentary version with 16 sourcing (high-side) switched outputs. The trailing "-000" model suffix denotes DC powered w/ CE & UL/cUL Class I, Division 2 Approvals.

Individual outputs of this model are open-drain switches for sinking loads up to 250mA and 32V DC each. Buffered inputs are TTL compatible and accept voltage levels from 0-32V DC. All I/O channels include 10K Ω pull-up resistors to I/O Excitation.

Reconfiguration of any XT model will require use of the XT-SIP configuration kit, ordered separately (see Accessories section).

Models are mounted on standard "T" Type DIN rail and include plug-in terminals. Power and excitation can be optionally (or redundantly) bussed along the DIN rail (see Power & Excitation Connections).

Digital Inputs

This model has tandem input and output channels. Always turn outputs OFF if using inputs to monitor field signals.

Sixteen active-low, buffered inputs, with a common return connection (RTN). For DC voltage applications only. Inputs are tied in tandem to the output drains and provide loopback monitoring of the output state. With the tandem output turned off, they may be used to monitor voltage levels from the field. Inputs include transient suppression and series connected 100K Ω resistors, plus diode over-voltage clamps to the internal +3.3V supply rail. Individual I/O channels are pulled up to the I/O excitation voltage (EXC terminal) with 10K Ω resistors. External excitation (the pull-up supply) is required for proper operation and is connected between the EXC and RTN terminals of TB6 (terminal numbers 22 and 21 respectively), or it can be optionally bussed along the DIN rail.

Input Signal Voltage Range: 0 to +32VDC.

Input Current: 280uA, typical at 32VDC. This is computed as the maximum applied input voltage minus 4V (3.3V rail and diode clamp), divided by the series 100K Ω input resistance.

Input Signal Threshold: TTL compatible w/100mV of hysteresis, typical. Low-to-High threshold is 1.7VDC, typical, High-to-Low threshold is 1.6VDC, typical. Logic limits are TTL with 0.8VDC Max LOW level, and 2.0VDC Min HIGH level.

Input Resistance: 100K Ω typical (input only), ~10K Ω w/ tandem output pulled up to EXC via its internal pullup.

Input Hysteresis: 100mVDC typical.

Input Response Time: 10ms typical, not including network time. The actual input response time will vary with network traffic and interrupts.

Input Transient Voltage Suppressor: Installed at every I/O point, up to 38V working, 47V breakdown, and 77V clamping.

Digital Outputs

This model has tandem input and output channels.

To control higher voltages and/or currents, or for controlling AC, an interposing relay may be used (see Note).

Note: Per UL, when the outputs are used to control interposing relays for switching AC and DC devices of higher voltage/current, the coil ratings for the interposing relay shall not exceed 24VDC, 100mA.

Sixteen open-drain, smart, n-channel mosfet switches with a common source connection at return (RTN). This model provides low-side or sinking switches between the load and return for DC voltage and current-sinking applications only. Outputs have tandem inputs which provide loopback monitoring of the output state. Individual I/O channels are pulled up to the I/O excitation voltage connected at the EXC terminal with 10K Ω resistors. External excitation (the pull-up supply) is required for I/O operation and is connected between the EXC and RTN terminals of TB6 (terminal numbers 22 and 21 respectively).

Output "OFF" Voltage Range: 0 to 32V DC. Limit voltage to less than 36V peak, or damage to the unit may result. Use protection when switching inductive loads, such as placing a reverse shunt diode across the inductive load to shunt the high reverse emf that develops when switching it OFF.

Output "ON" Current Range: 0 to 250mA DC, continuous (up to 4A total for all 16 channels combined up to 60°C). Deration of output load current is required above a 60°C operating ambient, at a rate of -22.5mA/°C per channel up to 70°C maximum (see Operating Temperature). Group one return (RTN) for each group of 4 outputs. The derated milliamperes/channel can be computed for a smaller number of channels (#ch) via the expression mA/ch=16*(1600-22.5*Ta)/#ch, where Ta is the maximum operating ambient in degrees Celsius from 60°C to 70°C and mA/ch must never exceed 250mA.

Output R_{ds} ON Resistance: 0.8 Ω typical, 1.6 Ω Maximum.

Over-Temperature Protection w/Thermal Shutdown: Individual outputs will shut down and latch off for thermal overload conditions that drive the junction temperature into the region from 150°-200°C to prevent destruction. In this case, the I/O pin is pulled high and the output must be recycled OFF/ON to reset the output (assuming device has cooled below 150°C).

Overvoltage Shutdown: Active during load dump or inductive load turn-off conditions and will cause the output to shut off if its drain-to-source voltage exceeds 36V. The switch can be turned on again by toggling it OFF/ON after this fault.

Over-Load Protection: The device will switch off to prevent destruction if the drain-to-source current exceeds 0.75A. It can be turned on again by toggling it OFF/ON after this fault condition.

Reverse Polarity Protection: Outputs integrate a reverse diode in the output switch that shunts reverse current through it, but the current in reverse must be limited by the load to prevent damage to the output switch via excess power dissipation. Note that over-temperature and over load protection are not active for reverse polarity.

Output "OFF" Leakage Current: 0.1uA typical, 50uA maximum (mosfet only, 25°C, 32V). Does not include the input bias current for the tandem digital input.

Note: The 100K Ω series input buffer resistors in combination with the +3.3V voltage diode clamps at the input buffer will tend to increase the off-state current with increasing drain voltage (up to 0.28mA at 32V), as the input buffer circuitry is connected in tandem to the output mosfet drain circuitry at every I/O pin.

Output Response Time: 10ms typical. Does not include network time. The actual switch time will vary with network traffic, interrupts, and output load.

General

Note: Do not allow EXC or unused inputs to float, as this will cause one I/O signal to pull the other floating port channels via the pull-ups and common EXC lead connection.

Excitation: External voltage of 4-32V is required between the I/O EXC and RTN terminals 22 and 21, or via the DIN rail bus. Excitation must be from 4-32V and source 52mA minimum (at 32V). Inputs cannot properly register the output OFF state if excitation is left floating. Also, each I/O channel is pulled-up to the EXC rail voltage (minus a diode drop) with a 10KΩ resistor. Without excitation, one output could pull the others via this common connection. Thus, you should not operate I/O without connecting Excitation. The EXC terminal is tied in common to one end of each channel pull-up resistor (internally the even-numbered pins of a four resistor SIP installed for each group of 4 consecutive channels).

I/O Pullups: Individual I/O channels include 10KΩ pullups to the excitation rail, to pull the open drain output and tandem input high (OFF). An external excitation supply is typically connected between the EXC+ and RTN terminals 22 and 21 of the module, or it can optionally be delivered via the DIN Rail bus. The installed resistor is one element of a four isolated SIP resistor network (8 pins) and rated to 0.3W per element up to 70°C (refer to Bourns 4308M-102-103LF parts). If your application requires a stronger pull-up (lower resistance), you will have to wire it externally in parallel with the internal 10K pullup, being careful that you never exceed 250mA of drain current per output.

Power

Power Supply (Connect at TB6 terminals 24 & 23, and/or via the DIN Rail Bus): 12-32V DC SELV (Safety Extra Low Voltage). Observe proper polarity. Reverse voltage protection is included. Unit can be redundantly powered by connecting power to both the power terminals on the unit and DIN rail bus (these power inputs are diode-coupled to the same point). Current draw varies with power voltage as follows (current indicated is with all outputs ON).

VOLTAGE	XT111x-000 SUPPLY CURRENT
12V	192mA Typical / 211mA Max
15V	151mA Typical / 166mA Max
24V	93mA Typical / 102mA Max
32V	70mA Typical / 77mA Max

CAUTION: Do not exceed 36VDC peak to avoid damage to the unit. Terminal voltage at or above 12V minimum must be maintained to the unit during operation.

Power Supply Effect: Less than ±0.001% of output span effect per volt DC change.

USB Interface



Unit includes a USB socket for temporary connection to a PC or laptop for setup and reconfiguration. USB isolation is recommended when connecting to a unit that may also be connected to grounded I/O signals. The unit does not receive power from USB and must already have DC power connected to it when connecting to USB.

CAUTION: Do not attempt to connect USB in a hazardous environment. Module should be setup and configured in a safe environment only.

Data Rate: USB 2.0 compatible, up to full-speed at 12Mbps.

USB Interface...

Transient Protection: Unit adds transient voltage protection to USB power and data lines when connected, but the unit does not use USB power.

Cable Length/Connection Distance: 5.0 meters maximum.

Driver: No special drivers required. Uses the built-in USB Human Interface Device (HID) drivers of the Windows Operating System (Windows XP or later versions only).

USB Connector: 5-pin, Mini USB B-type socket, Hirose UX60-MB-5S8.

PIN	DEFINITION
1	+5V Power (Transient protected, but not used by this model)
2	Differential Data (+)
3	Differential Data (-)
4	NC – Not Connected
5 ¹	Power Ground (Connects to Signal Ground via ferrite bead)
SHLD ¹	Signal Ground (Connects directly to Signal Ground)

¹**Note:** Most Host Personal Computers (except battery powered laptops) will connect earth ground to the USB shield and signal ground.

IMPORTANT – USB Isolation is recommended: The I/O of this module is isolated from each network port and DC power, but its I/O return is common to its USB connection. Most Personal computers (except DC powered laptops) connect their USB signal and shield ground to earth ground. Without a USB isolator, an earth grounded USB connection could drive a ground loop with any earth ground applied at its I/O, which might interfere with operation. For this reason, we recommend that you always use a USB isolator when making a USB connection to prevent a potential ground loop from affecting performance. Otherwise, in the absence of USB isolation, a battery powered laptop could be used to connect to the unit, as the laptop does not normally connect to earth ground.

Ethernet Interface

Connector: Dual, shielded RJ-45 sockets, 8-pin, 10BaseT/100BaseTX. The metal shield circuit of the network connectors are isolated and capacitively coupled to the input power minus terminal via an isolation capacitor.

Network-to-Network Isolation: Network ports are additionally isolated from each other and will withstand HIPOT voltages up to 1500Vrms, or 2250V DC.

Wiring: Unit includes auto-crossover for MDI or MDI-X cables.

Protocol: Modbus TCP/IP w/USB Configuration.

IP Address: Default mode static IP address is 192.168.1.100.

Port: Up to 16 sockets supported, uses port 502 (reserved for Modbus).

Data Rate: Auto-sensed, 10Mbps or 100Mbps.

Duplex: Auto-negotiated, Full or Half Duplex.

Compliance: IEEE 802.3, 802.3u, 802.3x.

Modbus TCP/IP Protocol Support: Up to 10 sockets may be selected for Modbus TCP/IP. The unit includes a built-in web page for ID on the network using a standard web-browser, but configuration of the unit is only possible using configuration software running on a Windows PC and connected via USB.

Ethernet Interface...

Communication Distance: The distance between two devices on an Ethernet network is generally limited to 100 meters using recommended copper cable. Distances may be extended using hubs, switches, or fiber optic transmission. However, the total round trip delay time must not exceed 512 bit times for collision detection to work properly.

Port Status Indicator: The blinking yellow LED of the network connector indicates network activity/traffic is present and the Ethernet connection is busy.

Address: The module IP address can be preset (static) by the user via USB. At startup, it can be loaded from internal non-volatile memory, or it can be automatically acquired via a network server using DHCP (Dynamic Host Configuration Protocol).

Refer to Acromag Application Note 8500-734 for instructions on how to change the IP address of your PC network interface card to talk to an Acromag module.

Enclosure & Physical

General purpose plastic enclosure for mounting on 35mm "T-type" DIN rail.

Dimensions: Width = 22.5mm (0.9 inches), Length = 114.5mm (4.51 inches), Depth = 99.0mm (3.90 inches). Refer to Mechanical Dimensions drawing.

I/O Connectors: Removable plug-in type terminal blocks rated for 12A/250V; AWG #26-12, stranded or solid copper wire.

Program Connector: USB Mini B-type, 5-pin socket, Hirose UX60-MB-5S8.

Case Material: Self-extinguishing polyamide, UL94 V-0 rated, color light gray. General purpose NEMA Type 1 enclosure.

Circuit Board: Military grade fire-retardant epoxy glass per IPC-4101/98.

DIN-Rail Mounting: Unit is normally mounted to 35x15mm, T-type DIN rails. Refer to the DIN Rail Mounting & Removal section for more details.

Shipping Weight: 0.5 pounds (0.22 Kg) packed.

Environmental

These limits represent the minimum requirements of the applicable standard, but this product has typically been tested to comply with higher standards in some cases.

Operating Temperature: -40°C to +60°C (-40°F to +140°F). Above 60°C (+140°F), derate the output current sinking capability as shown in the figure of the following page. For a smaller number of output channels, you can derate the full combined load of 4A (16 channels at 250mA each) at a rate of -360mA/°C above 60°C. For example, at 65°C you can compute a combined maximum load of $4A - (5 \times 0.36A) = 2.2A$, or 137mA per channel (2.2A/16ch). This is equivalent to 250mA/channel (8 channels), since you must never exceed 250mA/channel. This data applies to the unit mounted upright on a DIN rail allowing free air flow from the bottom vent through the unit and out the top vent.

Storage Temperature: -40°C to +85°C (-40°F to +185°F).

Relative Humidity: 5 to 95%, non-condensing.

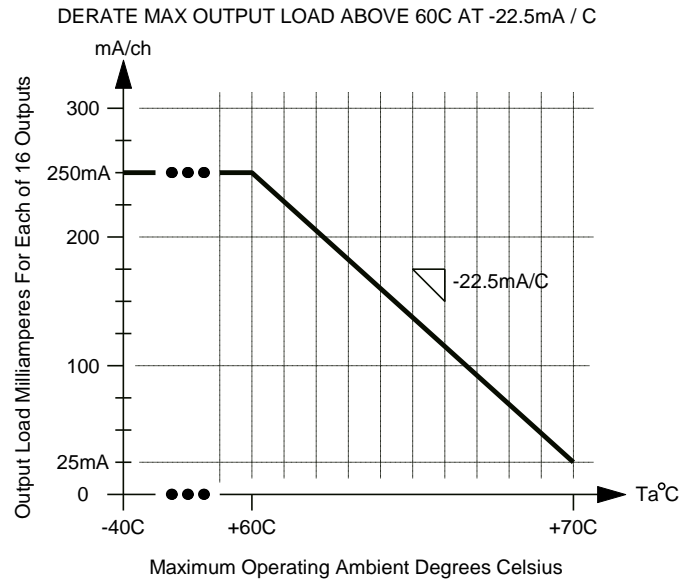
Environmental...

For Ta from 60C to 70C: $\text{mA/ch} = 1600 - 22.5 \cdot \text{Ta}$

For derated Ta with less than 16 output channels:

$\text{Ta} = [1600 - (\text{mA/ch} \cdot \text{\#ch} / 16)] / 22.5$

Isolation: Input/output channels, with Excitation, and including USB (as a group), network (including port-to-port), and the power circuit are isolated from each other for common-mode voltages up to 250VAC, or 354V DC off DC power ground, on a continuous basis (will withstand 1500VAC dielectric strength test for one minute without breakdown). This complies with test requirements of ANSI/ISA-82.01-1988 for voltage rating specified.

Installation Category: Suitable for installation in a Pollution Degree 2 environment with an Installation Category (Over-voltage Category) II rating per IEC 1010-1 (1990).

Shock & Vibration Immunity: Conforms to: IEC 60068-2-6: 10-500 Hz, 4G, 2 Hours/axis, for sinusoidal vibration; IEC 60068-2-64: 10-500 Hz, 4G-rms, 2 Hours/axis, for random vibration, and IEC 60068-2-27: 25G, 11ms half-sine, 18 shocks at 6 orientations, for mechanical shock.

Electromagnetic Compatibility (EMC)**Minimum Immunity per BS EN 61000-6-2:**

- 1) Electrostatic Discharge Immunity (ESD), per IEC 61000-4-2.
- 2) Radiated Field Immunity (RFI), per IEC 61000-4-4.
- 3) Electrical Fast Transient Immunity (EFT), per IEC 61000-4-4.
- 4) Surge Immunity, per IEC 61000-4-5.
- 5) Conducted RF Immunity (CRFI), per IEC 61000-4-6.

This is a Class A Product with Emissions per BS EN 61000-6-4:

- 1) Enclosure Port, per CISPR 16.
- 2) Low Voltage AC Mains Port, per CISPR 16.
- 3) Telecom / Network Port, per CISPR 22.

WARNING: This is a Class A product. In a domestic environment, this product may cause radio interference in which the user may be required to take adequate measures. Refer to the EMI Filter Installation drawing in the Electrical Connections section of this manual to install ferrite cable clamps that help to reduce radiated emissions. The use of low EMI double-shielded Ethernet cable is also helpful in curbing emissions.

Agency Approvals

Electromagnetic Compatibility (EMC): CE marked, per EMC Directive 2004/108/EC. Consult factory.

Safety Approvals: UL Listed (USA & Canada). Hazardous Locations – Class I, Division 2, Groups A, B, C, D Hazardous Location or Nonhazardous Locations only. These devices are open-type devices that are to be installed in an enclosure suitable for the environment. Consult Factory.

ATEX Certified: Model XT1111-000 is ATEX Certified for Explosive Atmospheres per ATEX Directive 94/9/EC which complies with standards BS EN 60079-0:2012 & BS EN 60079-15:2010.

⊕ II 3 G Ex nA IIC T4 Gc -40°C ≤ Ta ≤ +60°C

DEMKO 15 ATEX 1561X

X = Special Conditions

- 1) The equipment shall only be used in an area of not more than pollution degree 2, as defined in EN 60664-1.
- 2) The equipment shall be installed in an enclosure that provides a degree of protection not less than IP 54 and only accessible with the use of a tool in accordance with EN 60079-15.
- 3) Transient protection shall be provided that is set at a level not exceeding 140 % of the peak rated voltage value at the supply terminals to the equipment.

Reliability Prediction

Reliability Prediction

MTBF (Mean Time Between Failure): MTBF in hours using MIL-HDBK-217F, FN2. *Per MIL-HDBK-217, Ground Benign, Controlled, G_BG_C*

Temperature	MTBF (Hours)	MTBF (Years)	Failure Rate (FIT)
25°C	TBD hrs	TBD years	TBD
40°C	TBD hrs	TBD years	TBD

Configuration Controls

Software Configuration Only via USB

Although this module normally operates using Modbus TCP/IP over Ethernet, it can only be setup and configured via USB. Its behavior as a 16-channel digital input/output module is determined via program registers set using a temporary USB connection to a host computer or laptop running a Windows-compatible configuration software program specific to the model. This software provides the framework for digital control of all configuration parameters, and this information is stored in non-volatile memory.

LED Indicators:

RUN (Green) – Located at front panel. Constant ON if power is on, unit is OK, and Ethernet cable is properly plugged in. Flashes ON/OFF during initialization, or if it keeps flashing continuously, then it indicates the network board has not initialized, perhaps because the network cable is unplugged or defective.

ST (Yellow) – Located at front panel. Blinks if a watchdog timeout has occurred.

ACT (Yellow) – Located on RJ45 port connector. Indicates Ethernet activity, the Ethernet connection is busy and traffic is present.

Refer to Configuration Step-by-Step in the Technical Reference section of this manual for detailed information on available software control of this model.

REVISION HISTORY

The following table details the revision history for this document:

Release Date	Version	EGR/DOC	Description of Revision
26-MAR-2013	A	BC/KLK	Initial Acromag release.
19-AUG-2013	B	BC/KLK	CE Approval added.
09-SEP-2013	C	BC/KLK	Replace incorrect DOUT drawing of page 11 w/ DIN dwg.
16-OCT-2013	D	BC/KLK	Corrected typos, added i2o and troubleshooting info.
21-FEB-2014	E	CAP/ARP	Added cULus Mark to this model (removed pending).
31-JUL-2014	F	CAP/ARP	Added UL caution symbols / statements.
15-OCT-2015	G	CAP/ARP	Added ATEX symbols / statements.
27-JAN-2016	H	BC/MJO	Added note to Closed Dry Connection drawing on page 11.
19-AUG-2016	J	CAP/MJO	Corrected "Circuit Board" specification.
13 NOV 2017	K	FJM/ARP	Reference Configuration Software without the revision.
5-SEP-18	L	BC/MJO	Improved Clarity & Fixed Drawings of pages 11, 12, 27.