



Document No.: STSE-PU-TG390MCAB-R04

## Specifications for Magnetically Suspended Compound Molecular Pump

### 1. Specifications

<b>Model</b>		<b>TG390MCAB</b>
Outside view drawing attached		X4-00071<2>
Inlet flange		CF100 <sup>1)</sup>
Outlet flange		KF25 <sup>2)</sup>
Cooling system		Forced air cooling
Bearing system		Active 5-axis control magnetic bearing
Volume flow rate	for N <sub>2</sub>	340 L/s
	for N <sub>2</sub> with protective screen	320 L/s
	for H <sub>2</sub>	290 L/s
Maximum compression ratio	for N <sub>2</sub>	1 × 10 <sup>8</sup>
	for H <sub>2</sub>	4.5 × 10 <sup>3</sup>
Ultimate pressure <sup>3)</sup>		< 1 × 10 <sup>-7</sup> Pa (7.5 × 10 <sup>-10</sup> Torr)
Maximum throughput <sup>4) 5)</sup>	for N <sub>2</sub>	3680 Pa·L/s (2000 sccm)
	for Ar	1290 Pa·L/s (700 sccm)
Maximum backing pressure		400 Pa (3 Torr)
Recommended backing pump		≥ 160 L/min
Startup time <sup>6)</sup>		2 – 3 min
Shutdown time <sup>6)</sup>		4 – 5 min
Permissible bake-out temperature at inlet flange		≤ 120 °C
Vibration (0 – peak) <sup>7)</sup>		≤ 0.01 μm
Rated rotational speed		40800 min <sup>-1</sup>
Installation position <sup>8)</sup>		Any
Permissible ambient temperature		10 – 32 °C
Gas purge throughput <sup>5) 10)</sup>		18.4 Pa·L/s (10 sccm)
Major materials <sup>9)</sup>		Stainless steel (pump body)
		Al alloy (rotor, stator)
Weight		17 kg

1) JVIS003 conflat flange

2) ISO2861/1 clamped type flange

3) Pressure attained after 48 hours of bake-out.

4) Maximum throughput when a backing pump with its volume flow rate of 320 L/min is used and the ambient temperature is 20-25 °C.

5) 1 Pa·L/s (25°C) = 0.543 sccm (0°C, 1 atm)

6) Backing pressure ≤ 10 Pa

7) Vibration peak at rated rotational speed measured with FFT.

8) Pump must be firmly secured to customer's system. (See the instruction manual for detail.)

9) Do not pump Hg, Ga and its compounds or corrosive gases. It may damage pump.

10) Use an optional gas purge inlet port.



Document No.: STSE-PU-TG390MCAB-R04

## 2. Accessories

For inlet flange	Temporary blank flange	1 ea.
	Bolts and nuts for temporary blank flange	1 set
	O-ring for temporary blank flange	1 ea.
	Protective screen (4 × 4 mm <sup>1)</sup> , Stainless steel)	1 ea.
For outlet flange	Blank flange	1 ea.
	Centering ring with FKM O-ring	1 ea.
	Clamp	1 set
Instruction manual		1 copy

1) Mesh size of each open area

## 3. Shop inspection

Prior to release for shipment, each magnetically suspended compound molecular pump is tested to ensure it passes the following inspection criteria.

Inspection item	Criteria
Exterior check	No abnormality detected by visual check
Helium leak test	Less than $1.3 \times 10^{-9}$ Pa·m <sup>3</sup> /s
Insulation resistance measurement <sup>1) 2)</sup>	Higher than 100 M Ω
Withstand voltage test Motor – Earth (Ground) Motor – Others <sup>2)</sup>	Leakage current less than 1.0 mA. AC1,500V 1min. AC2,230V 1min.
Rotational direction	Clockwise
Rated rotational speed	Within 5% deviation from specified rated rotational speed
Startup time	In the range of specified startup time
Shutdown time	In the range of specified shutdown time
Inlet pressure measurement	Lower than $5 \times 10^{-5}$ Pa ( $4 \times 10^{-7}$ Torr) after 2 hours of evacuation without bake-out
Running test	No abnormality during continuous operation

1) By DC 500V mega-tester

2) Some sensors are excepted.

2 17000 - 4X DWG. NO.

JOB NO.	NO.	DESCRIPTION	MATERIAL	Q'TY	DWG. NO.	REMARKS

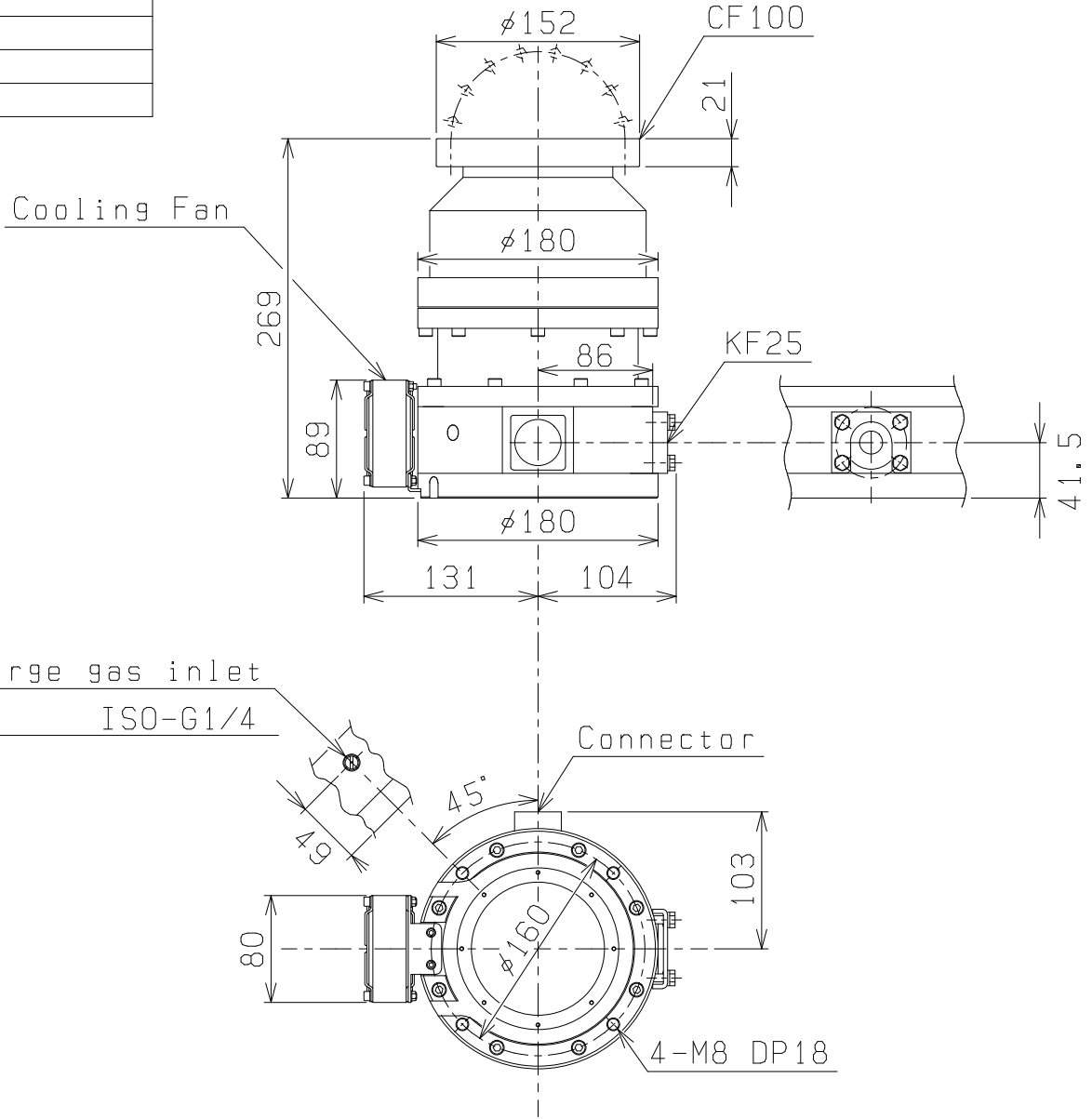

REV. NO.	DATE	DESCRIPTION	DR'N	CH'D	APP'D
④					
③					
②	2002.11.11	排気口押え形状訂正	石森	大和	中安
①	2002.06.25	G1/4 規格表記	大林	井口	井口
CHECKED	APPROVED	NO. OF SET	DATE		
石森	大林	SET	2002.02.27		
DRAWN	DESIGNED	SCALE			
大和	大和	1/5			

TITLE  
**TG390MCAB**  
**Dimensions**

**OSAKA VACUUM, LTD.**

DWG. NO. X4 - 00071



Specifications for Turbo Controller

1. Specification

<b>Model</b>	<b>TC010MA</b>		
<b>Pump Model</b>	<b>TG390M / TG420M</b>	<b>TG900M / TG1300M</b>	<b>TG2400M</b>
<b>Input Voltage</b>	<b>AC180 – 264 V</b>		
<b>Phase</b>	<b>Single</b>		
<b>Frequency</b>	<b>50/60 Hz</b>		
<b>Power</b>	<b>Max. 0.7 kVA</b>	<b>Max. 1.2 kVA</b>	<b>Max. 1.2 kVA</b>
<b>Rated Output Frequency</b>	<b>680 Hz</b>	<b>560 Hz</b>	<b>520 Hz</b>
<b>Permissible Ambient Temperature</b>	<b>5 – 40 °C</b>		
<b>Humidity</b>	<b>5 – 80 %</b>		
<b>Weight</b>	<b>11 kg</b>		
<b>Warning functions</b> <sup>1)</sup>	<b>Touch down counter warning:</b> When the number-of-times limit of durability of protection bearing approached.		
	<b>Unbalance warning:</b> When shaft movement due to unbalance for byproducts disposition etc. reached the warning level.		
	<b>Maintenance time warning:</b> When operation time reached at the time to require maintenance.		
	<b>Low battery warning:</b> When the capacity of the battery for clock backup decreased.		
	<b>Controller reboot warning:</b> When the controller has been booted up continuously over one year.		
<b>Protective functions</b> (Continue to next page)	<b>Self check error protection:</b> When an error occurred in self-check of the controller.		
	<b>Matching error protection:</b> When mismatch between pump model and controller setting occurred.		
	<b>Cable connection failure protection:</b> When output cable was unplugged.		
	<b>Sensor tuning error protection:</b> When an error occurred during the sensor calibration.		
	<b>Fan absence protection:</b> (Air-cooling type pump) When fan cable was unplugged. (Water-cooling type pump) When terminator for fan cable was unplugged.		
	<b>Displacement failure protection:</b> When shaft movement for external vibration etc. exceeded the specified level.		
	<b>Active Magnetic Bearing overload protection:</b> When magnetic bearing load exceeded the specified level for air inrush etc.		
	<b>Rotation detector failure protection:</b> When an error occurred in rotation detective circuit.		
	<b>Change safety bearing protection:</b> <sup>2)</sup> When rotor has touched down specified times, the pump cannot be restarted.		
	<b>Unbalance failure protection:</b> When shaft movement due to unbalance for byproducts disposition etc. exceeded the specified level.		
	<b>Motor overheat protection:</b> When pump inside motor became overheat.		
	<b>Power amplifier overheat protection:</b> When amplifier of controller became overheat.		
	<b>DSP board overheat protection:</b> When Digital Signal Processor board of controller became overheat.		
	<b>Inverter over-voltage protection:</b> When over-voltage occurred in inverter of the controller.		
<b>Output over-current protection:</b> When over-current occurred in inverter of the controller.			



(Continue from previous page)	<b>Delay in acceleration protection:</b> When pump rotor failed to accelerate at the specified rate for overload etc.
	<b>Input voltage loss or drop-off protection:</b> When input voltage was interrupted or drops off during 3 seconds or more.
	<b>Over speed protection:</b> When rotation speed exceeded 105 % of the maximum speed.
	<b>Interlock protection:</b> When protection signal of the remote input was opened.
<b>Communication interface</b>	<b>RS232C</b>
<b>Outside view drawing attached</b>	<b>X3-04718</b>
<b>I/O signal diagram attached</b>	<b>X3-04759</b>

- 1) Although controller performed warning display (lit ALARM led/output ALARM signal/display warning on the LCD), pump operation can be continue. Order overhaul of pump and controller to OSAKA VACUUM as soon as possible.
- 2) When this protection function operated, it becomes impossible to start a pump after it. Order to OSAKA VACUUM overhaul of the pump.

## 2. Accessories

Attached part name	Quantity
Remote connector	1 ea.
Input cable 5meters (16.4 ft)	1 ea.
Instruction manual	1 copy

## 3. Shop inspection

Prior to release for shipment, each controller is tested to ensure it passes the following inspection criteria.

Inspection item	Criteria
Exterior check	No abnormality detected by visual check
Insulation resistance measurement <sup>3),4)</sup> Input power – Earth (Ground)	≥ 100 MΩ
Withstand voltage test <sup>3)</sup> Input power and motor output – Earth (Ground) Input power and motor output – Others	No abnormality detected AC1,500V 1min. AC2,230V 1min.
Operation test Check for start/stop Check for input/output signal Check for protective functions	No abnormality detected

3) Serge absorber removes and carries out.

4) By DC 1,000 V mega-tester





# TG390M Throughput (for N<sub>2</sub>)

Doc. No. : ND00391<1>

Ref. No. :  
Date : 2002. 07. 26  
Issued : Y. Ishimori  
Checked : T. Ohbayashi  
Approved : M. Iguchi

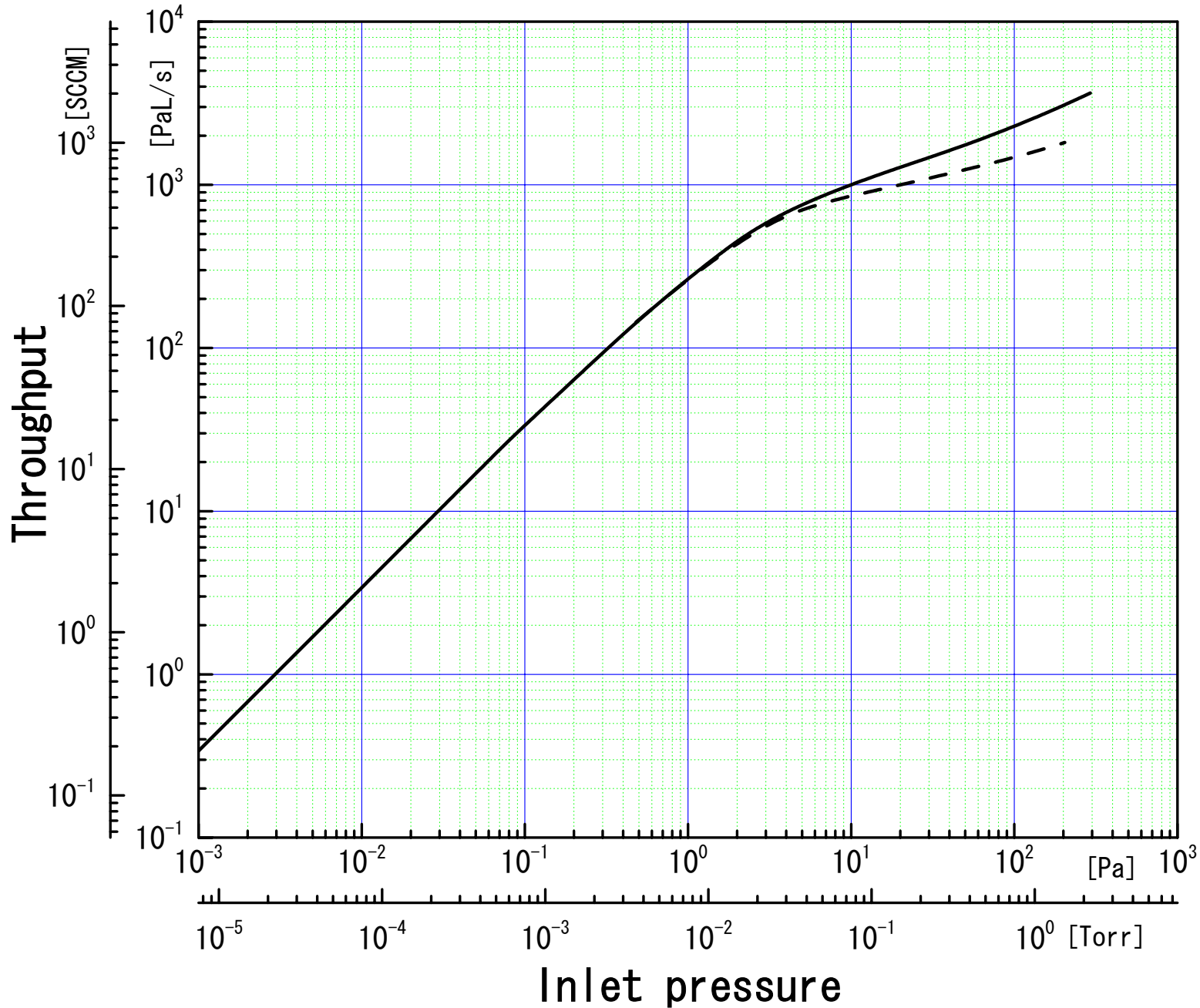

Sf: Volume flow rate of backing pump

without Protective screen

# TG390M Throughput (for Ar)

Doc. No. : ND00393

Ref. No. :  
Date : 2002. 06. 20  
Issued : M. Yoshida  
Checked : Y. Ishimori  
Approved : T. Ohbayashi

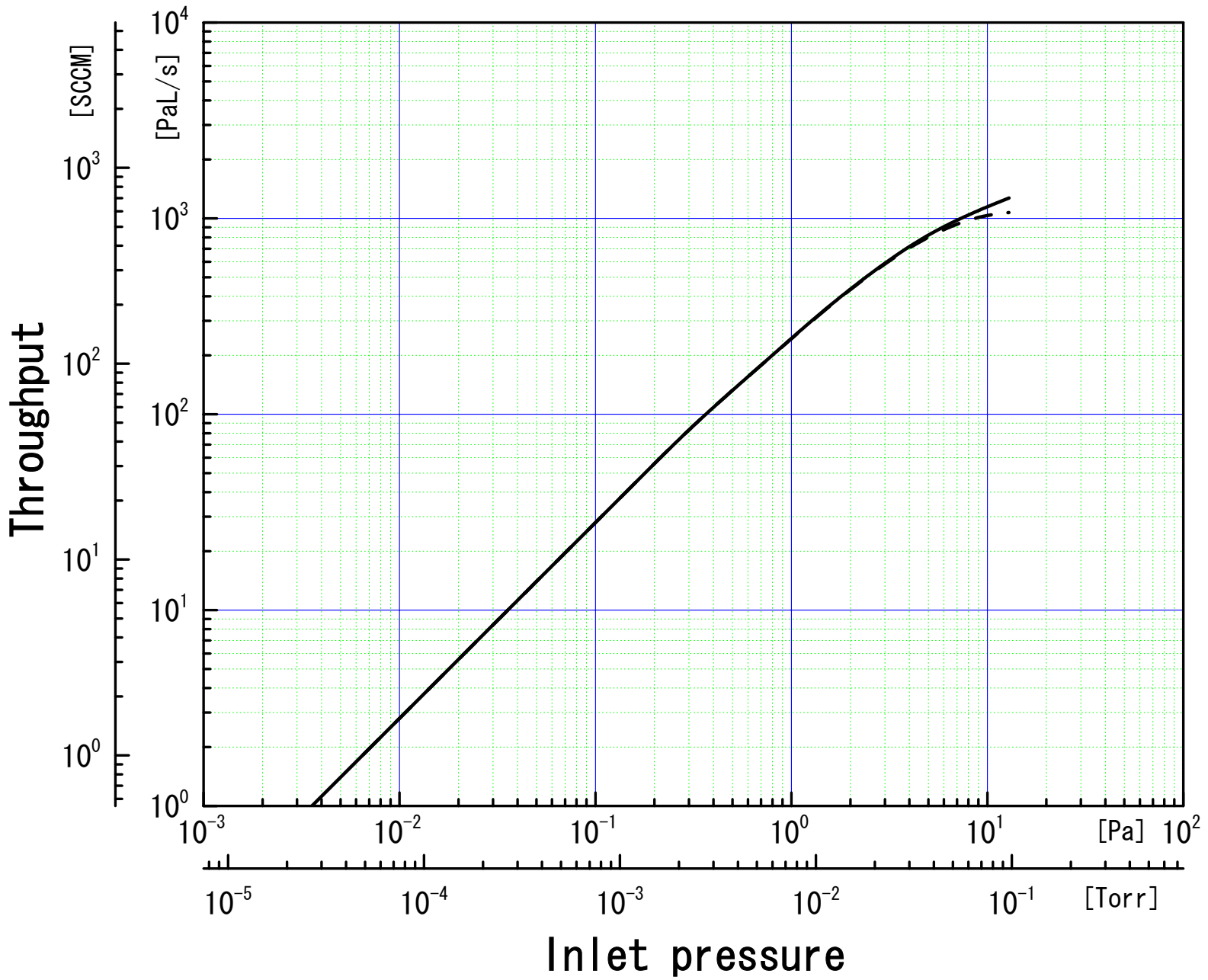

— Sf=320L/min  
- - Sf=160L/min

Sf: Volume flow rate of backing pump

without Protective screen

# TG390M Throughput (for H<sub>2</sub>)

Doc. No. : ND00392

Ref. No. :  
Date : 2002. 06. 20  
Issued : M. Yoshida  
Checked : Y. Ishimori  
Approved : T. Ohbayashi

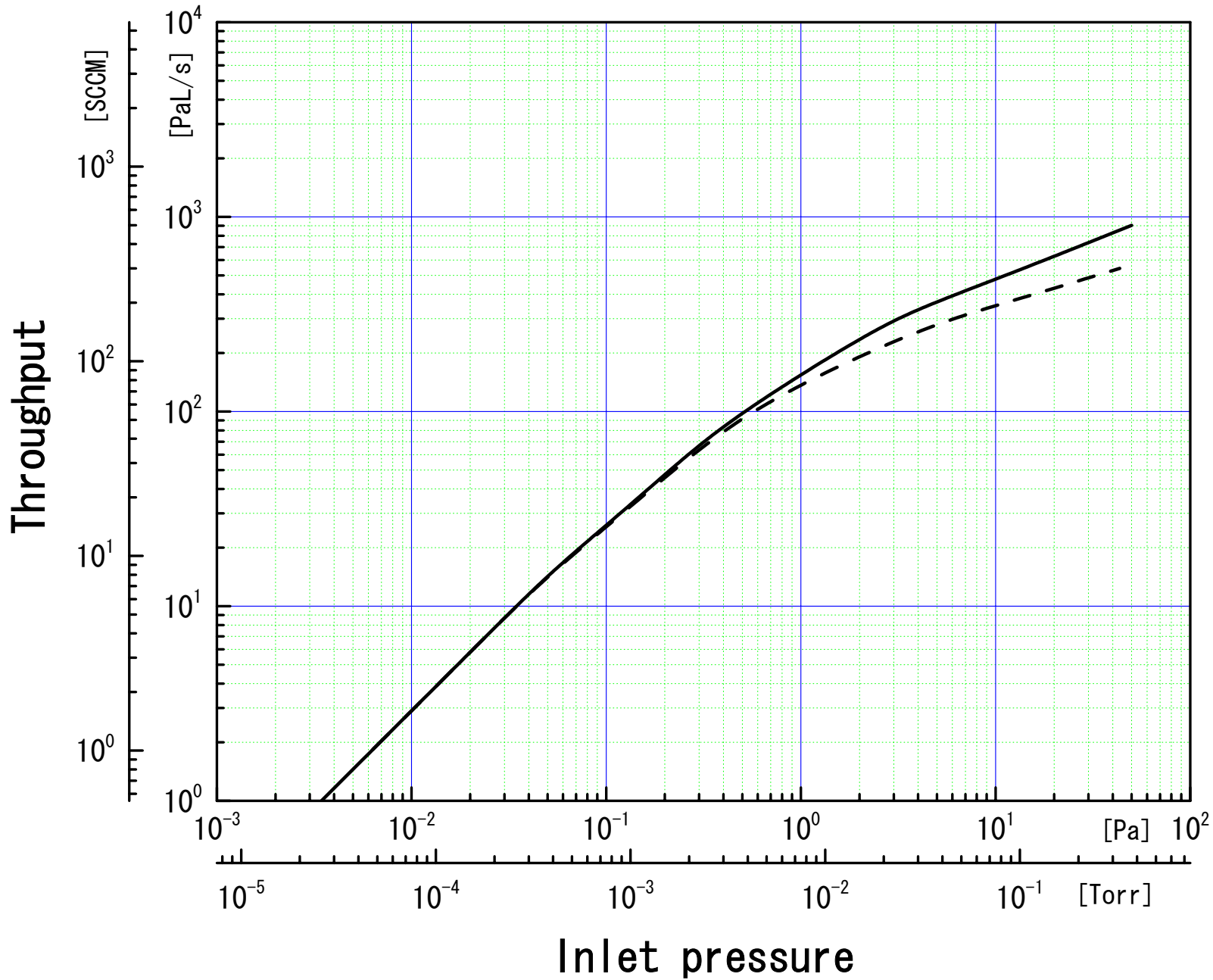

Sf: Volume flow rate of  
backing pump

without Protective screen